



The "Must Have" Manual of  
**OUTDOOR POWER EQUIPMENT**  
BOOK 2 - REAR ENGINE RIDERS & LAWN TRACTORS



Technical Service Information for the MTD Product Line



MTD Product Training and Education

MTD SERVICE LLC Product Training and Education Department

# TABLE OF CONTENTS

<b>WORK SAFETY</b> .....	<b>Section 1</b>
<b>GENERAL INFORMATION</b> .....	<b>Section 2</b>
Safety Precautions .....	2-1
Batteries And Charging Systems .....	2-2
<b>ELECTRICAL</b> .....	<b>Section 3</b>
Safety Interlock Systems .....	3-1
Safety Interlock Systems - Changes for 1991 .....	3-1
Electric Start System .....	3-3
Recoil Start System .....	3-6
Safety Interlock Systems Wiring Diagrams .....	3-10
Troubleshooting Safety Interlock Systems .....	3-23
Evaluating Electric Clutches .....	3-56
<b>BELTS AND DRIVE SYSTEM</b> .....	<b>Section 4</b>
General .....	4-1
Proper Storage of Belts .....	4-3
Causes of V-Belt Problems .....	4-3
V-Belt Problems with Rotary Tillers, Self-Propelled Mowers and Riding Mowers .....	4-4
Belt Wear Due to Normal Life .....	4-5
Pulley Alignment .....	4-6
Idlers .....	4-6
Maintenance Of Variable Speed Pulleys .....	4-9
Four Wheel Steering .....	4-10
Disassembly Of Four Wheel Steering .....	4-13
Brake Adjustment for 600 and 700 Series .....	4-15
<b>HYDROSTATIC</b> .....	<b>Section 5</b>
<b>TRANSAXLES</b> .....	<b>Section 6</b>
General .....	6-1
Transaxle Changes For 1990, 1991, 1992 and 1997 Models .....	6-3
Disassembly/Assembly of Transaxle .....	6-5
Hydrostatic Transaxle .....	6-13
Integrated Hydrostatic Transaxle .....	6-17
<b>LAWN TRACTORS</b> .....	<b>Section 7</b>
300 and 400 Series .....	7-1
Rear Engine Riding Mowers 500 Series .....	7-6
Transmatic LT 600A .....	7-9
Hydrostatic Drive 700 Series .....	7-35
<b>YARD BUG</b> .....	<b>Section 8</b>
Deck Leveling .....	8-1
Brake Adjustment .....	8-3
Blade Brake/PTO Adjustment .....	8-5
Speed Control Pedal Adjustment .....	8-6
Steering Adjustment .....	8-9
Removal and Installation of Deck Belt .....	8-11
Removal and Installation of Mowing Deck Assembly .....	8-12
Removal and Replacement of the Drive Belts .....	8-14
Transmission Removal and Installation .....	8-16
Transmission Disassembly .....	8-18
Transmission Reassembly .....	8-20
Electrical .....	8-23

1

2

3

4

5

6

7

8



<b>AUTO DRIVE</b> .....	<b>Section 9</b>
Leveling the Cutting Deck .....	9-1
Deck Belt Removal and Installation .....	9-3
Cutting Deck Removal .....	9-4
Brake Adjustments .....	9-5
Autodrive Pedal Adjustment .....	9-5
Drive Belt Removal and Reinstallation .....	9-6
Transmission Removal and Installation .....	9-9
Transmission Disassembly and Reassembly .....	9-11
Deck Belt Removal .....	9-14
Hydrostatic Transmission Removal .....	9-16
Steering Adjustments .....	9-20
Electrical .....	9-21
Autodrive/Autocruise .....	9-30

<b>MTD Z SERIES</b> .....	<b>Section 10</b>
Transmission .....	10-1
Neutral/Steering Adjustment .....	10-1
Removal of ZTT Transmission .....	10-8
Transmission Disassembly .....	10-13

<b>ZERO TURN TRACTORS</b> .....	<b>Section 11</b>
624 Zero Turn Tractor - The Revolution .....	11-1
46" Cutting Deck .....	11-2
Cutting Deck Removal .....	11-2
Lower Deck Belt Removal .....	11-3
Servicing the IZT Drive Belt .....	11-3
Servicing the IZT .....	11-7
Adjustments to the IZT .....	11-9
Parking Brake .....	11-10
Under Dash Service Points1 .....	11-11
Dash Panel Removal .....	11-12
Front Axle .....	11-16

<b>ATTACHMENTS</b> .....	<b>Section 12</b>
Cutting Decks .....	12-3
Improvements .....	12-22
Grass Collectors .....	12-37
Front Bumper .....	12-39
Trapac .....	12-39
42" Dozer Blade .....	12-40

**GLOSSARY**

# WORK SAFELY—FOLLOW THESE RULES

This symbol is used to call your attention to instructions concerning your personal safety. Be sure to observe and follow these instructions.

1. To prevent accidental starting, always pull the high tension wire(s) off the spark plug(s) before servicing and/or adjusting the machine.
2. To prevent injury, do not allow children or bystanders around the machine while it is being adjusted and/or serviced.
3. Do not wear rings, wrist watches or loose fitting clothing when working on machinery; they could catch on moving parts causing serious injury. Wear sturdy, rough-soled work shoes. Never adjust and/or service a machine in bare feet, sandals or sneakers.
4. Always wear safety glasses when using a hammer, chisel or other tools that may cause chips to fly.
5. Be sure to reinstall safety devices, guards or shields after adjusting and/or servicing the machine.
6. When operating a power washer to clean a machine before servicing, be careful at all times to avoid injury. Maintain proper footing and balance at all times. Never direct the spray at people or animals, as high pressure spray can cause serious injury.
7. If a portable heater is used to heat the service area, the following precautions must be observed
  - a. Do not use portable heaters in presence of volatile materials such as gasoline or paint, as fire or explosion may result.
  - b. To avoid being burned, do not touch the heater during operation.
  - c. Portable heaters consume oxygen and combustion fumes can be hazardous. Heater should be used only in a well-ventilated area. Keep a window or door partially open to provide ventilation.
  - d. Keep the heater at least four feet from combustible materials.
  - e. Never use gasoline as fuel.
8. Handle gasoline with care—it is highly flammable.
  - a. Use approved gasoline container.
  - b. Never remove the fuel tank cap or fill the fuel tank when the engine is running, is hot or indoors. Also, do not smoke when working around flammable fuel.
  - c. Avoid fires—be sure container or funnel does not touch the battery. Do not overfill the fuel tank. Wipe up spilled gasoline.
  - d. Replace fuel tank cap securely.
9. Never use trouble lights or electric powered tools that have cut and/or damaged cords or plugs. Be sure all electric tools are properly grounded.
10. Never run an engine in a confined area such as a garage or storage building any longer than is necessary for immediate moving of the machine out of or into the area. **EXHAUST GASES ARE TOXIC. OPENING DOORS AND WINDOWS MAY NOT PROVIDE ADEQUATE VENTILATION.**
11. After servicing, be sure all tools, parts or servicing equipment are removed from the machine.
12. Electrical storage batteries give off highly inflammable hydrogen gas when charging and continue to do so for some time after receiving a steady charge. Do not under any circumstances allow an electric spark or an open flame near the battery. Always disconnect a battery cable before working on the electrical system.

13. Hydraulic fluid escaping under pressure can have enough force to penetrate the skin. Hydraulic fluid may also infect a minor cut or opening in the skin. If injured by escaping fluid, see a doctor at once. Serious infection or reaction can result if medical treatment is not given immediately. Do not attempt to repair or tighten hoses that are under pressure, when the boom is raised or with the tractor engine running. Cycle all hydraulic control valves to relieve all pressure before disconnecting the lines or performing other work on the hydraulic system. Make sure all connections are tight and hoses and lines are in good condition before applying pressure to the system. To locate a leak under pressure, use a small piece of cardboard or wood. Never use hands.
  14. When using an acetylene torch, always wear welding goggles and gloves. Keep a charged fire extinguisher within reach. Do not weld or heat areas near fuel tanks or fuel lines and utilize proper shielding around hydraulic lines.
  15. Always use safety stands in conjunction with hydraulic jacks or hoists. Do not rely on the jack or hoist to carry the load; it could fail. Always use a safety bar to block hydraulic cylinders.
  16. When splitting tractors or disassembling machines, be sure to use safety stands and adequate supports to prevent tipping or roll-over.
  17. Use a safety catch on all hoist hooks. Do not take a chance, the load could slip off the hook.
  18. Use pullers to remove bearings, bushings, gears, cylinder sleeves, etc. when applicable. Use hammers, punches and chisels only when absolutely necessary. Then, be sure to wear safety glasses.
  19. Be careful when using compressed air to dry parts. Use approved air blow guns, do not exceed 30 psi, wear safety glasses or goggles and use proper shielding to protect everyone in the work area.
  20. Petroleum based solvents, often used for cleaning parts, are flammable. Use care to avoid fire or explosion when using these solvents.
- IMPORTANT:** The above is only a partial list of safe work rules. In addition, always refer to the Operator's Manual for the specific machine for additional safe work rules regarding the machine operation.

# GENERAL INFORMATION AND SAFETY PRECAUTIONS

## 2-1. SAFETY PRECAUTIONS.

2-1.1 Refer to the Safety Summary on page 1-1, and observe all WARNINGS and CAUTIONS when servicing equipment covered in this manual.

## 2-2. GENERAL.

2-2.1 This service manual covers lawn mowers, riding equipment, snowthrowers, chore performers, rotary tillers and accessories through model year 1998.

2-2.2 More detailed instructions can be found in each of the individual model service manuals.

## 2-3. REFERENCE DATA.

2-3.1 Serial Number Location. Serial number plate is located behind the seat on the rear fender. See Figure 2-1.

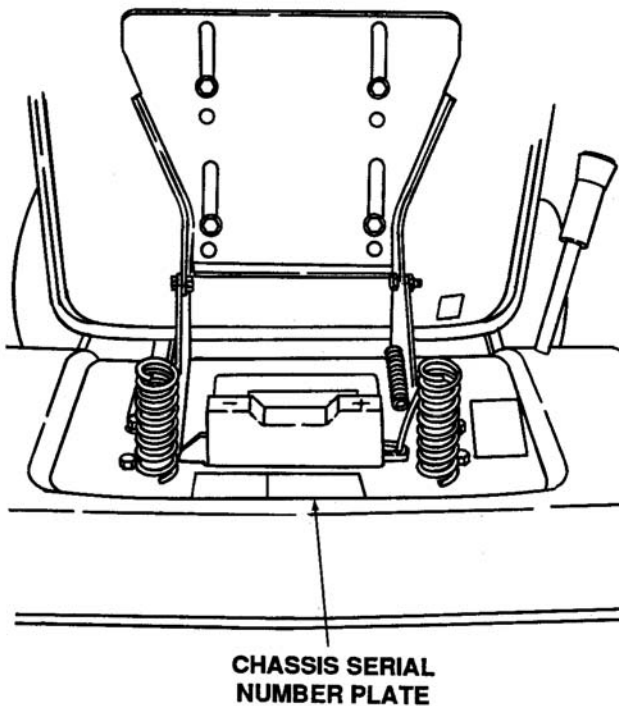


Figure 2-1. Chassis Serial Number

### ➔ NOTE

LEFT and RIGHT indicate the left and right side when facing forward in the driver's seat or behind the piece of equipment.

## 2-4. NUMBERING SYSTEM.

2-4.1 Due to the many different models, types of equipment and parts, it is very important to understand the MTD numbering system and how it is used. The following pages, Figures and Tables will explain the system and what each number and digit means.

### ➔ NOTE

IMPORTANT: When ordering replacement parts, it is necessary to use both the model number and the date code.

2-4.2 Due to the many different colors of rims and different tire tread designs on riding mowers, orders for replacement tires and wheel assemblies must specify both color and tire brand. These can be identified by using the appropriate 900 series number after the part number.

### ➔ NOTE

If you are entering an order electronically, the tire identification number can be entered where the paint code number is entered for a painted part.

## 2-5. CUSTOMER NUMBERS.

2-5.1 In addition to customers who purchase tractors and equipment marked with the MTD brand and name logos, there are customers who order tractors and equipment marked with their own brand name and/or logos. Basic units are the same except for color and decoration.

## 2-6. GENERAL.

2-6.1 The main storage or electrical power in our electric start lawn mowers, riders and tractors is the battery. With proper setup and mainte-



# BATTERIES AND CHARGING SYSTEMS

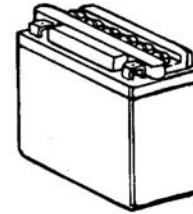
nance the battery will last for years. However, in some remote cases even with proper maintenance a battery can lose power. This is unavoidable and should be handled as per warranty guidelines.

- 2-6.2 A chemical reaction between the battery's electrolyte and plates, or electrodes, will supply electrical energy to an external circuit. When the battery is being used, or discharging, the positive plate (lead dioxide) and the negative plate (sponge lead) are both changed to lead sulphate. At the same time, part of the electrolyte (diluted sulfuric acid) is changed to water. This conversion of diluted sulfuric acid to water reduces the specific gravity of the electrolyte. By measuring this specific gravity, a direct measure of how far the discharge process has progressed can be made.

## 2-7. BATTERIES AND CHARGING RATES.

- 2-7.1 There are basically 5 different batteries used. In this section we will show the battery number, the replacement number, cause of replacement, size, cold cranking amps and amp hours at a given rate.

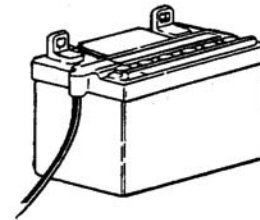
1. Battery 725-0514A (Figure 2-2) is replaced by 725-1633. These batteries are used on riders and are the same size with the same cold cranking amps. The number was changed due to shipping regulations which would not allow acid packs to be shipped with batteries. Acid packs can be obtained by ordering part number 725-1637; however, we suggest dealer obtain acid locally. Battery caps, part number 725-0691, can also be ordered separately.



**LENGTH** 5-9/32"  
**WIDTH** 3-1/2"  
**HEIGHT** 5-11/16"  
**VOLTAGE** 12 VOLT  
**CHARGING RATE 1.4 AMPS 3-5 HOURS**  
**COLD CRANKING AMPS 125**  
**14 AMP HOURS AT 10 HOURS RATE**

**Figure 2-2. Battery 725-0514A**

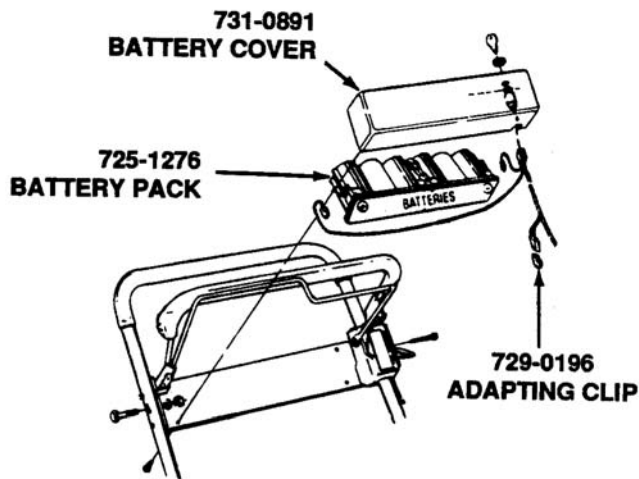
2. Battery 725-0453A (Figure 2-3) is shipped with no acid. Acid can be obtained by ordering part number 725-1637, but it is suggested acid be purchased locally. Battery caps can also be purchased separately by ordering part number 725-0690. Battery 725-0453A was used on 1989 and prior 700 and 800 series tractors. This battery is currently used in the 900 series tractor.



**LENGTH** 7-3/4"  
**WIDTH** 5-3/16"  
**HEIGHT** 6-11/16"  
**VOLTAGE** 12 VOLT  
**CHARGING RATE 3 AMPS 3-5 HOURS**  
**COLD CRANKING AMPS 240**  
**30 AMP HOURS AT 20 HOURS RATE**

**Figure 2-3. Battery 725-0453A**

3. Battery 725-1105 which was supplied in 1987 is no longer available. Use kit number 753-0459 as a replacement. The kit includes a battery, cover and adapting clip. The larger terminal end goes on the negative side of the battery. The adapting clip also goes on the negative side. The electric start unit uses a 7 amp fuse system
4. Battery pack 725-1276 (Figure 2-4) is installed in electric lawn mowers.



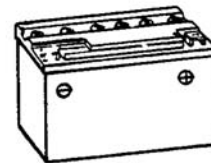
**LENGTH**        8-3/4"  
**WIDTH**         1-3/4"  
**HEIGHT**         2-3/4"  
**VOLTAGE**        12 VOLT  
**2.5 AMP HOURS SEALED**  
**LEAD ACID**

**Figure 2-4. Battery Pack 725-1276**

**➔ NOTE**

During shipment, the hot wire can vibrate off the battery and the unit will not start. Take the battery cover off, hook up the wire and charge the battery.

5. Battery 725-1430 (Figure 2-5) is replaced by 725-1635. These batteries are the same size with the same cold cranking amp. The number was changed due to shipping regulations which do not allow acid packs to be shipped with batteries. Acid packs can be obtained by ordering part number 725-1637; however, we suggest dealers obtain acid locally.



**LENGTH**                    8-1/8"  
**WIDTH**                     3-9/16"  
**HEIGHT**                    6-7/16"  
**VOLTAGE**                   12 VOLT  
**CHARGING RATE 2 AMPS FOR 3-5 HOURS**  
**COLD CRANKING AMPS 275**  
**20 AMP HOURS AT 10 HOURS RATE**

**Figure 2-5. Battery 725-1430**

**➔ NOTE**

Batteries 725-1430 only contain a special chemical sulfate stop that has been added to reduce sulfate crystal deposits (which eventually prevent the battery from accepting a charge). Sulfate stop is a white powder chemical that may be visible before the battery is activated, but dissolved once electrolyte is added. After charging the battery (with sulfate stop added), the specific gravity of electrolyte rises to 1.280 or above. On a 5 ball hydrometer, it is acceptable to see the fifth ball float. If the battery contains sulfate stop and has not been in use for a long period of time, extended recharging time is required.

## 2-7.2 BATTERIES SECTION 1996-1998

### #725-0453 E

#### Battery Type U1-11L

Dry 380 CCA Cold Cranking Amps @ Zero Degrees  
Group No. U1L  
Voltage 12V  
Size Top 5.18 x 7.7  
Number of plates 66  
Height 6.12 to top of post 7.16  
Weight wet 20.6 lbs.  
Electrolyte capacity 72 oz.

Previously this battery was 240 CCA and it has been upgraded to 380 CCA which gives added cranking power in cold weather. It is shipped dry and it is suggested that the acid should be purchased locally. The acid pack number as shown is #725-1670 but acid is considered to be hazardous material, therefore when shipped, charges will be excessive due to special handling.

### Battery #725-1704

Note! New Warning symbols  
Battery Type U-1  
Wet 125 CCA Cold Cranking Amps  
All batteries are date coded  
Replaced by #725-1707 C DRY 275 CCA Cold Cranking Amps  
Size 5.18 x 7.7  
Height 6.12 with Post 7.29  
Voltage 12 volts

The #725-1704 is a wet battery meaning that it is shipped in the rider and it is hooked up with the positive terminal connected and the negative terminal has a plastic cover over it to protect from shorting out. The purpose of this is to assist stores with fast product turnover and in this manner the unit is ready to operate in the least amount of set-up time.

### Battery #725-1705C

WET 150 CCA Cold Cranking Amps.  
Battery Type U-1  
All batteries are date coded  
Replaced by #725-1707C DRY 275 CCA Cold Cranking Amps.  
Voltage 12V

The #725-1705C is a wet battery and it is the same as stated above. If a failure occurs in warranty the #725-1707C will be shipped.

### Battery #725-1706

WET 270 CCA Cold Cranking Amps.  
Battery Type U-1  
Negative terminal covered with a plastic cover and shipped with the positive cable connected.  
Replaced by #725-1707C DRY 275 CCA Cold Cranking Amp.  
All batteries are date coded  
Battery is non-serviceable  
Voltage 12V

The #725-1706 is a wet battery and is shipped in the tractor and is ready to go by just removing the plastic cover on the negative terminal and connecting the negative cable to the negative terminal.

### Battery #725-1707C

DRY 275 CCA Cold Cranking Amps.  
Battery Type U-1 Flat Top  
Size 5.19 x 7.72  
Height 6.12 Including Post 7.30  
Voltage 12V  
Manifold Vented

Specifications for '97-'98 will be the same except all will be flat top style. The knobs will be flush with the top of the battery.

YUASA - EXIDE makes the DRY, add acid type batteries EAST PENN makes the WET non-serviceable type battery.

WET batteries are anticipated to be used in 50% of our production for fast moving product customers, all batteries can not be shipped wet because they would have a shorter shelf life than a dry battery.

For '97-'98 little changes are anticipated. Dependability over all styles will remain the same. Replacement batteries will continue to be shipped without acid, and acid must be obtained locally due to acid being a hazardous material, therefore requires special handling when shipped.

New for '98 season batteries will be similar in size but top will be flat with nothing sticking up except the posts. Fill caps will be flush with the top of the battery.

Batteries must be properly maintained if you want long-life, this remark is repeated over and over.

1. Check the electrolyte and add only water.
2. Keep clean, excessive acid build up around the terminals and top of battery will cause a discharge and drain the battery.
3. Check cables and clamps and battery case for obvious reasons of leakage as this could cause damage to the painted surfaces, the battery compartments and to the pulleys and transmission.
4. Make sure of the routing of the vent tubes and that it is not pinched and left to drip on pulleys, etc.
5. Replace caps firmly, if one or two gets lost, replace them as soon as possible, often they can be obtained from old batteries.
6. Maintain a fully charged battery with a reading by hydrometer showing 1.265.

2-7.3 Recently, a man well experienced in automobiles and lawn and garden equipment was charging a battery in his automobile in the garage for a long period of time and decided to check on how it was progressing. He walked into a partially dark garage, not thinking, and leaned over the battery and flipped on this cigarette lighter. Well, you can guess what happened next. The electrolyte gas exploded, which is hydrogen and oxygen. He was very lucky to have glasses on as the top of the battery hit him in the face. He quickly remembered to turn the hose on his face and wash off the acid which was starting to burn and no damage was done, but he was left quite shaken and thankful that things worse didn't take place. Think about it. His glasses were broken and bent tight to his eyes which helped protect his eyes, which proves it is a good practice to wear glasses when working with batteries.

**2-8. BATTERY STARTING CIRCUITS.**

- 2-8.1 Battery starting circuits consists of the following:
- Battery as a source of energy
  - Starter solenoid switch to transfer high starting current from battery to starter (starter relay)
  - Key start switch or other switch to energize the starter solenoid

•Starter. A series wound, low resistance, high current draw direct current motor.

**NOTE**

Sometimes the circuit breaker kicks out and will not allow the unit to crank. Check the diode wires to see if they are crossed. Reverse the diode wires if crossed.

**2-9. BATTERY CHARGING SYSTEM.**

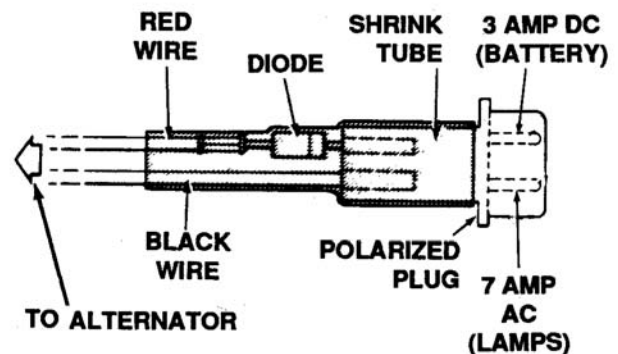
- 2-9.1 There are four types of charging systems typically used on lawn and garden equipment.
- Single circuit—3 amp system with one diode
  - Dual circuit—3 amp AC system that runs the lights and a 3 amp DC circuit to charge battery
  - Tri-circuit—5 amp two diode system
  - Regulated 16 amp system

MTD mainly uses the dual circuit and regulated systems.

- 2-9.2 Regulated systems are installed on units with electric clutches. These are Briggs and Stratton engines with a voltage regulator. Some of the early units had an 8 amp circuit breaker in the unit. This is a 16 amp unit and needs a 20 amp circuit breaker (part number 725-1382).

**2-9.3 Dual Circuit (Engine Alternator) (Figure 2-6).**

1. The charging system is an alternator located under the flywheel. A half wave rectification (single diode) is unregulated and rated at 3 amps at 3600 RPM.

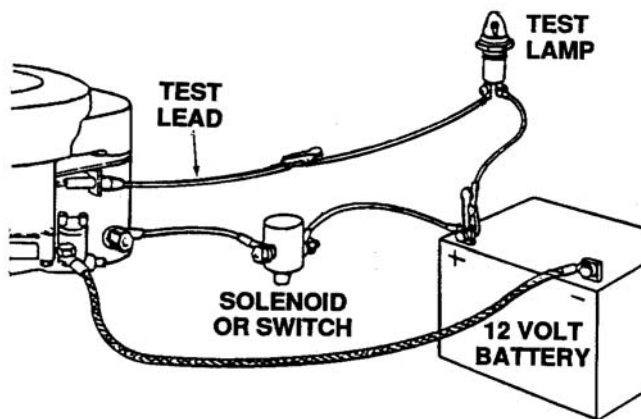


**Figure 2-6. Dual Circuit**



2. The diode changes AC to DC to charge the battery. A bad diode can either fail to charge the battery or discharge the battery if the alternator is shorted as well as the diode.
3. The 7 amp AC terminal operates the head lamps. The voltage rises from 8 volts at 2400 RPM to 12 volts at 3600 RPM. Therefore, the brightness of the lights changes with engine speed. In certain situations it is necessary to make use of the entire AC signal. To accomplish this we use multiple diodes in a bridge configuration. This produces full wave rectification (regulator) which is regulated and rated 16 amps at 3600 RPM.
4. The 16 amp DC terminal at 3600 RPM operates the head lamp. The regulated system produces 12 volts DC which goes to the battery. Engine speed will determine amount of amps regulated.

#### 2-9.4 Testing the DC Circuit (Figure 2-7).



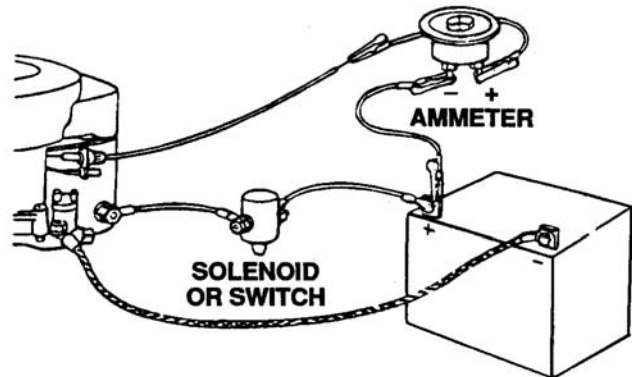
**Figure 2-7. DC Circuit**

1. Disconnect the charger lead from the battery (small red wire).
2. Connect a 12 volt test lamp between the DC charge lead and the positive terminal of the battery.
3. With the engine off, the lamp should not light. If it does, the diode and possibly the alternator may have failed.
4. Start the engine. The lamp should light. If it does not, the alternator (starter) or lead wire could be bad.

#### 2-9.5. Battery Runs Down.

##### 2-9.5.1 Testing Alternator Charging Output.

Install ammeter in series with charging lead. See Figure 2-8. Start engine. Ammeter should indicate charge. The charge rate is dependent upon the condition of the battery. If ammeter shows no charge, test stator and regulator.



**Figure 2-8. Alternator Charging Output**

#### 2-10. BATTERY SHIPPING AND STORAGE.

##### 2-10.1 Check List For Proper Battery Storage.

1. Electrolyte level correct.
2. Battery fully charged.
3. The exterior of the battery is clean.
4. Store battery in a cool place.
5. Rotate stock. Always use the oldest battery first.

##### 2.10.2 Dry Charged Battery Storage.

1. A dry charged battery has a shelf life of about five years.
2. Keep in a cool, dry place with the humidity as low as possible with a temperature between 60°F and 90°F. The temperature should be uniform and not subject to frequent changes.
3. Once a dry charged battery is actuated, it must be maintained the same as any wet battery.

**2-10.3 Wet Battery Storage.**

1. Wet batteries will slowly discharge while in storage.
2. Batteries not used in the winter should be stored in a fully charged condition.
3. Batteries in storage discharge slower when kept cold than when too warm.
4. The best place to store the battery is in the equipment.

**2-11. ACTIVATING BATTERY.**

2-11.1 The instructions listed below are packed with every battery shipped with each unit. Following these steps will prevent premature battery failure.



**WARNING**

LAWN AND GARDEN EQUIPMENT BATTERY (DRY AND CHARGED) FILLING AND INSTALLATION INSTRUCTIONS. Do not fill with electrolyte until battery is actually placed in service. This battery is supplied dry and charged. Do not fill with electrolyte until battery is to be used.



**WARNING**

POISON—CAUSES SEVERE BURNS. Contains sulfuric acid. Avoid contact with skin, eyes or clothing. To prevent accidents, neutralize excess acid with baking soda and rinse empty container with water. KEEP OUT OF THE REACH OF CHILDREN.

**ANTIDOTE:**

EXTERNAL—Flush with water.

INTERNAL—Drink large quantities of water or milk. Follow with milk of magnesia, beaten eggs or vegetable oil. Call physician immediately

EYES—Flush with water for 15 minutes and get prompt medical attention.



**WARNING**

DANGER—BATTERY CONTAINS SULFURIC ACID MAY CONTAIN EXPLOSIVE GASES.

•Keep sparks, flame, cigarettes or any flame away.

•Shield eyes, protect skin and clothing when handling acid or battery containing acid or working near such batteries.

•Ventilate when charging or using battery in enclosed space.

•Make sure venting path of battery is always open once battery is filled with acid.



**NOTE**

When the battery is charged, the heat will expand the electrolyte.

1. Allow the battery to sit 20 to 30 minutes. This allows the chemical action to take place.
2. The battery must be charged at the maximum rate until a specific gravity is reached. See paragraph 2-1.4.
3. Add electrolyte until it reaches the split ring.



**CAUTION**

DO NOT ADD ACID. Add only distilled water.

4. After charging, replace vent plugs firmly, wash off acid spillage with water and dry the battery.
5. If time does not permit charging the battery, or if charging equipment is not available, the battery should be installed and the unit should be run continuously for 20 to 30 minutes in order to sufficiently charge the battery.

2-11.2 Preparation for filling the battery is very important.

1. Remove vent plugs just before filling with electrolyte.



### WARNING

Internal gas pressure can cause battery to explode if sealing tube is left in place.

2. If your battery has a short sealing tube on the vent elbow and is supplied with a separate long tube, pull off short one and replace with long one.



### WARNING

Electrolyte is sulfuric acid solution. Avoid spillage and contact with skin, eyes and clothing. See WARNING on back panel of battery.



### CAUTION

Do not use water or any other liquid to activate. During cold weather, if electrolyte (acid) is stored in cold area, warm electrolyte to room temperature before filling.

3. Fill battery with electrolyte (diluted sulfuric acid) of a specific gravity of 1.265. Fill to upper level as indicated on battery. Electrolyte should be at room temperature before filling.

## 2-12. BATTERY INSTALLATION INSTRUCTIONS.

1. Remove old battery. Mark which cable is connected to positive (+) and negative (-) terminals. Positive cable is usually red.
2. Clean cable connectors with wire brush or sand paper to remove oxidation.
3. After filling with acid and charging (see instructions), install new battery. Connect cables to the proper terminals. Positive cable to positive terminal (+) and negative cable to negative terminal (-). **CONNECT NEGATIVE CABLE LAST.**



### CAUTION

Connecting in reverse, positive to negative and negative to positive, can cause serious damage to electrical system.

4. Check vent tube to avoid any crimping or obstruction to the tube.
5. Securely fasten battery to the unit using its battery hold-down arrangement. This will minimize destructive vibration.

## 2-13. COMMON CAUSES FOR BATTERY FAILURE.

2-13.1 Overcharging. Charging a battery greatly in excess of what is required is harmful in several ways, as follows:

1. Severely corrodes the positive plate grids with consequent mechanical weakening and loss of electrical conduction.
2. Decomposes water of electrolyte into hydrogen and oxygen gas. Gas bubbles tend to wash active material from the plates and carry moisture and acid from the cells as a fine mist.
3. Decomposition of water leaves acid more concentrated. Concentrated acid is harmful to cell components, particularly at high temperatures over a prolonged period of time.
4. High internal heat is created, which accelerates the above mentioned corrosion of positive plate grids and damages separators and negatives. Also, containers may be softened and distorted.
5. Overcharging alone or in combination with a previous condition of undercharging may cause severe buckling and warping of positive plates with accompanying perforation of separators.
6. May cause damage by corrosion to battery box, cables and other vital electrical and engine parts by forcing liquid from the cells if charge rates are excessive.

### 2-13.2 Undercharging.

1. A battery operated with insufficient charge over a long period of time may develop a type of sulfate in the plates which is dense, hard and coarsely crystalline and which cannot be readily electrochemically converted to normal active material again. Such lead sulfate, being less dense than the active material from which it was formed, will set up strains in the positive plates so that distortion or bowing of the plates, called buckling, may result. Buckling will be produced, especially if the sulfated battery is subjected to sudden prolonged overcharging, as might be experienced by an alternator or generator-regulator system which has gotten out of adjustment. Severely buckled plates will pinch the separators at the plate corners or chafe the center of the separators. This may result in perforations of the separators and develop a short circuit in the cell.
2. A battery operated in an undercharged condition is not only unable to deliver full power, but is liable to freeze during severe winter weather. See par graph 2-8.7.
3. Lead sulfate formed on the plates during discharge is relatively insoluble as long as the specific gravity of the electrolyte indicates a substantially charged condition. If allowed to drop much below this state the lead sulfate becomes increasingly soluble and, aided by temperature fluctuations of the electrolyte, may migrate over a considerable period of time into the pores of the separators and deposit as a white crystalline mass. Subsequent charging may convert these crystalline deposits to metallic lead which may short the positive and negative plates through the areas of the separators affected. These small shorts may cause a condition of low cell voltage when the battery is charged. For this reason battery cells should not be allowed to stand idle in a discharged condition.

**2-13.3 Lack of Water.** Water is one of the essential chemicals of a lead-acid storage battery and under normal conditions of operation is the only component of the battery which is lost as a result of charging. It should be replaced as soon as the liquid level falls to the top of the separators. If water is not replaced, and the

plates are exposed, the acid will reach a dangerously high concentration that may char and disintegrate the separators and may permanently sulfate and impair the performance of the plates. Plates can not take full part in the battery action unless they are completely covered by the electrolyte. Sulfuric acid **must never** be added to a cell unless it is known that acid has been spilled out or otherwise loose from the cell.

**2-13.4 Loose Holddowns.** Holddowns, if not properly adjusted, may allow the battery to bounce around in the battery box. This may cause the bridges on which the elements rest to notch the bottom of the separators and may cause the plates to notch the bridge tops causing a severe disarrangement of the elements. The bouncing of the battery may also crack or wear the container badly and cause acid to leak. Leaking acid corrodes terminals and cables and results in high resistance battery connections, thereby weakening the battery's power and shortening its life. If holddowns are too tight, they can distort or crack the container, allowing loss of acid from the cells. This will cause loss of battery capacity.

**2-13.5 Battery Electrolyte Substitutes.** No satisfactory substitute electrolyte has been found for the simple mixture of sulfuric acid in water. Use no substitutes.

**2-13.6 Excessive Loads.** A battery should never be used to propel the rider by the use of the starting motor with clutch engaged except in a great emergency. This may produce extremely high internal battery temperature and damage the starting motor.

### 2-13.7 Freezing of Electrolyte.

1. The electrolyte of a battery in various states of charge will start to freeze at temperatures indicated below. The given temperatures indicate the approximate points at which the first ice crystals begin to appear in the solution. The solution does not freeze solid until a lower temperature is reached. Solid freezing of the electrolyte may crack the container and damage the positive plates.



2. A 3/4 charged automotive battery is in no danger from freezing. Keep batteries at 3/4 charge or more, especially during winter weather.
3. Battery power decreases while the need for engine power increases with falling temperatures.
 

80°F	100%
32°F	66%
0°F	46%
4. Sub-zero temperatures reduce the capacity of a fully charged battery to 30% of its normal power and at the same time increases cranking load beyond the normal warm weather load.

**➔ NOTE**

The above failures do not constitute a warranty.

**2-14. TESTING THE BATTERY.**

2-14.1 A visual inspection of battery should be done by checking for:

1. Broken or leaking cover.
2. Broken case.
3. Damaged post.
4. Other.

2-14.2 Batteries should be handled with care. Never leave battery standing in a discharged position.



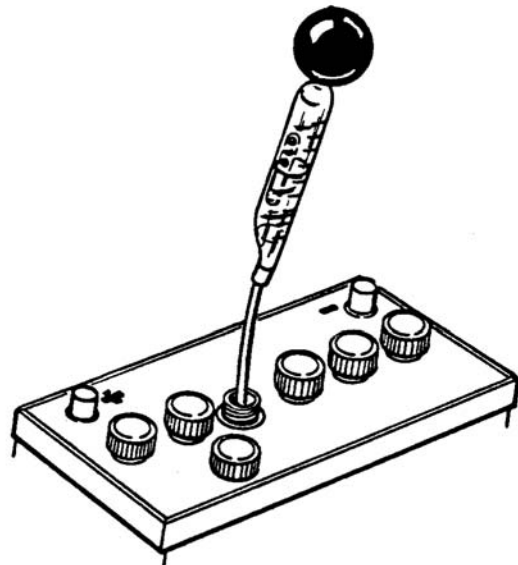
**WARNING**

Never test a battery by striking a cable across the output terminals. An internally shorted battery could EXPLODE.

2-14.3 The hydrometer measures the state of charge. Use of the hydrometer will also pinpoint a shorted cell which, in some instances, cannot be charged or will not hold a charge. See Figure 2-9.

1. Specific gravity tests must be performed before adding water to the battery.
2. In the event the electrolyte level is too low to test with the hydrometer, add water and charge before testing.

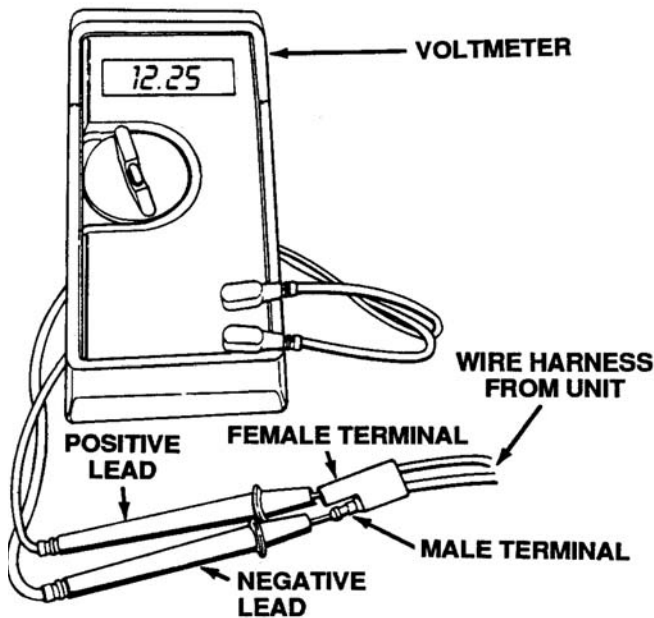
3. A correct specific gravity reading can be measured only when the electrolyte temperature is 80°F. If the electrolyte temperature varies from this temperature, compensation must be made in the reading as follows:
  - a. Add four gravity points (.004) for each 10° electrolyte temperature is above 80°F.
  - b. Subtract .004 for each 10° below 80°F.



**Figure 2-9. Using Hydrometer**

4. In taking the hydrometer reading, the float must be floating freely and the eye must be even with the liquid level to obtain accurate readings.
5. When all cells are tested, if the specific gravity between the highest and lowest cell varies 50 points (.050) or more, condemn the battery; it is no longer serviceable.
6. If there is less than a 50 point variation between the highest and lowest cell, and the specific gravity in one or more cells is below 1.235, recharge the battery.
7. The inability to bring the specific gravity of any one cell up to 1.235 after charging is also an indication of an unserviceable battery and it should be condemned.
8. After the recharge, let the battery stand at least 24 hours, and repeat hydrometer test on all cells. If there is a variation of 50 points or more between the highest and lowest cell, condemn the battery.

2-14.4 Batteries 725-1105 and 725-1276 are 12 volt sealed lead-acid batteries. These batteries can be checked by using a standard DC voltmeter. When checking the voltage, the male terminal of the connector plug of the harness is the negative terminal. See Figure 2-10.



**Figure 2-10. DC Voltmeter**

2-14.5 Check battery charge with voltmeter as follows:

**NOTE**

Check to be certain the in-line fuse in the wire harness is OD.

1. Connect the negative lead of the voltmeter into the male end of the plug on the wire harness.
2. Connect the positive lead of the voltmeter into the female pin on the plug on the wire harness.
3. A fully charged battery will register 13.0 volts on the voltmeter.
4. A battery that needs charging should read between 11.0 and 13.0 volts.
5. If the reading is below 10.0 volts on the voltmeter, the battery probably will not accept a charge and should be replaced.

**2-15. BATTERY CHARGERS AND CHARGING.**

**2-15.1 Restore charge.**

1. An electric current is sent through the cell in the reverse direction to that in which the current flows when the battery is delivering current. The charging rate must be slightly higher than the voltage. A single battery cell produces approximately 2 volts. A 12 volt battery will consist of six 2 volt cells. To charge a 12 volt battery requires (.5 volts x 6 cells = 3 volts) (12 volts + 3 volts = 15 volts). When a battery is discharged, its internal resistance is low. In this low resistance condition, the battery will draw a greater charging current. As the battery becomes charged, the internal resistance increases and the current draw will diminish.
2. Batteries should only be tested with a hydrometer for specific gravity, or a test device that applies a current draw to the battery while testing. A voltmeter does not give an accurate indication of battery condition, as even a partially discharged battery will indicate correct voltage when not under load. The normal specific gravity of a charged battery should be between 1.285 and 1.300 approximately. A discharged battery cell has a specific gravity of 1.150 approximately.

2-15.2 Recharging is necessary when you find lights get dim, and/or when battery is not used for longer than one month. Charge the 12 volt battery with a 12 volt 1 amp automotive charger. Recommended charging for 6 volt or a 12 volt battery should not exceed 1 amp. Charge until battery gases freely and specific gravity of electrolyte rises to 1.265 or above.

**WARNING**

When charging, care must be taken to ventilate the fumes from the battery as they are highly **EXPLOSIVE**. The gases issuing from a charging battery are a mixture of hydrogen and oxygen gases and will explode with great violence and spraying of acid if a spark or flame is brought too near them. A room or compartment in which charging batteries are confined should be ventilated. Do not bring flame or sparks near vent openings.

**WARNING**

In all automotive battery cells small quantities of hydrogen gas are given off at the negative plates when the cells are not being charged. It

must therefore be assumed that explosive mixtures of hydrogen gas are present within the cells at all times. A torch, match flame, lighted cigarette or sparks from metal tools accidentally contacting the terminals could cause ignition of the gases.



### WARNING

To avoid sparks, do not disturb connections between batteries while charging; first throw switch "off" at the charger. The possibility of ignition of hydrogen gas by static electricity when working on or near batteries is minimized by grounding ones self and the vehicle to remove any static charge.



### WARNING

The improper use of a booster battery to start a rider, when the normal battery is inadequate, presents a definite explosion hazard. To minimize this hazard the following procedures are suggested.



### CAUTION

Exceeding the recommended charging rate can cause warping of the plates and will affect the life of the battery.

1. When possible, use equipment with a switch in the line connecting the booster battery to the installed battery. Check to see that both batteries have the same voltage type: e.g., 6 volt or 12 volt.
2. If only jumper cables are available and the booster battery is in a car, set the hand brakes, turn off accessory switches and ignition keys and place the gearshift or gear selector in the neutral or park position for both vehicles. Now proceed in exact sequence.
3. Always rock the connector clips to insure secure grip contact.
  - a. Connect one end of first cable to the terminal of the discharged battery which is connected to the starter switch or solenoid (not grounded). Note if this is the positive or negative battery terminal.
  - b. Connect the other end of the first cable to the terminal post of the booster battery having the same marking; that is, positive to positive or

negative to negative. Most have a negative grounded electrical system.

- c. Connect the first end of the second jumper cable to the other terminal of the booster battery. With the other end make final connection and this is to be the rider frame of the mower with the discharged battery as far away as possible from the battery.

### 2-15.3 Charging the Battery.

1. Connect the charger to the lawn mower harness.
2. Plug the charger into a 110 volt AC wall outlet.
3. Check the charger after 15 minutes. The charger should be warm to the touch (approximately 100°F).



### WARNING

Charger could be HOT and cause burns.

4. If the charger is hot, it is drawing too much current and should be disconnected immediately. One of the following conditions exist:
  - a. The battery is defective.
  - b. The polarity of the battery connectors is reversed.
  - c. There is a short in the wire harness.
5. If the charger is cold to the touch, one of the following conditions exist:
  - a. The battery is not connected to the wire harness.
  - b. The charger is bad. Check the output voltage. It should be above 9 volts DC with the male terminal of the charger being positive.
  - c. There is no voltage present at the wall socket.
  - d. The charger should be checked once more by touch within an hour. Use caution when touching the charger.
6. Normally, if the unit starts the first time, it is unlikely that the wire harness is defective. However, if the wire harness is suspect after using the above procedures, it should be replaced.

2-15.4 Plug-in Trickle Chargers. Different trickle chargers are used for different batteries. The following is a list of chargers and the rate at which the batteries are to be charged.

Plug-In Trickle Chargers

- 725-0727 300 ma. use on 725-1105 and 725-1276 battery
- 725-0507 1/2 amp charger, used on 725-0415
- 725-0579 Alligator clips for 725-0507 charger to be used when charger does not plug into the wire harness
- 725-0156 Old red Schauer charger. Not available. Use 753-0220. This kit consists of:
  - 1 725-0507 charger
  - 1 725-0579

**Charging Rates**

- 725-0130 automotive type with tapered terminals 15 amp maximum
- 725-0453
- 725-0661 4-5 amp maximum
- 725-0117
- 725-0726 300 ma. elec. start self-propelled
- 725-1104 lawn mowers
- 725-1276
- 725-0514 motorcycle type 3 amp maximum

2-15.5 **New Information Concerning Battery Charging.**

It is important that new batteries are charged according to the owner's guide or Technical Handbooks Volume I, II and III. We have found that rider and tractor batteries do not have memories, and the capability of recharging a low or dead battery is feasible. A 3 to 10 amp taper charger should be used; charging time varies between 12 to 40 hours. This charging procedure should be followed prior to checking the specific gravity or condemning any rider or tractor battery.

**Table 2-1. Specific Gravity Freezing Points**

Specific Gravity	Freezing Point
1.265	-75°F
1.225	-35°F
1.200	-17°F

1.150	5°F
1.100	18°F
1.050	27°F

**2-16 MAINTENANCE AND SERVICE.**

2-16.1 Proper maintenance and service could extend the life of a battery. The following procedures should be taken:

1. Clean battery top with a stiff brush, being careful not to scatter corrosion products. Wipe off with a cloth wetted with ammonia or baking soda in water. Fully wipe with a cloth with clean water.
2. Inspect cables—urge replacement if unserviceable. Inspect the terminals posts to see that they are not deformed or broken.
3. Clean the battery and cable contact surface to a bright metal finish whenever they are removed. Coat the contact surfaces with mineral grease or petroleum jelly before the terminals are reconnected.
4. Inspect battery box and adjust holddowns. Urge replacement if unserviceable.
5. Check electrolyte level once a month. If found below middle of UPPER and LOWER LEVEL, add clean drinking water to restore level.



**WARNING**

NEVER use ACID to refill a battery.

6. Make hydrometer or voltage test.
7. Keep exhaust tube free of kinks and obstructions.
8. Store battery with a full charge. A discharged battery will freeze.



**NOTE**

All batteries discharge during storage. Recharge battery every two months and before returning to service.

9. Carefully inspect and recharge the battery at the beginning and end of each mowing season.



# SAFETY INTERLOCK SYSTEMS

## 3-1. GENERAL.

- 3-1.1 There are two basic electric wiring systems used: one for battery start models and one for recoil start models. All safety systems used are based on the same principle.
- 3-1.2 Most riders and tractors produced in 1982 were equipped with a reverse safety switch. This safety system required the cutting deck to be disengaged before the unit can be shifted into reverse gear. These systems will be used on all current production units.
- 3-1.3 The lift and disengagement lever is used to raise and lower the cutting deck which determines the cutting height. Pulling it all the way back and locking it disengages the blades. The lift and disengagement lever **MUST** be in the disengaged position when starting the engine, when shifting into reverse or if the operator leaves the seat.
- 3-1.4 All lawn and garden tractors produced after July, 1987 were requested by ANSI (American National Standards Institute) to have an operator present as an added safety feature. If the operator leaves the seat with the blades or PTO engaged, the engine will shut off. This seat switch is a safety device, designed for your protection. See Figure 3-1.



### WARNING

NEVER attempt to bypass this operation.

- 3-1.5 In mid 1986, safety switches were added to most lawn and garden tractors, internally mounted in the seat.
- 3-1.6 On 1988 production, the location and type of safety switch was changed on most front engine lawn tractors. It was mounted on the seat bracket under the seat and it will shut off the engine with the deck engaged, with less than 40 lbs. of weight on the safety seat.
- 3-1.7 The 1990 riders and tractors have incorporated a new seat safety switch. The operator must engage the parking brake before leaving seat or unit will stall out. This new switch will also be present on riders and tractors with electric PTO's.



### WARNING

NEVER attempt to bypass this operation.

- 3-1.8 For further information regarding this section, refer to the Technical Service Video "Safety Interlock Systems."

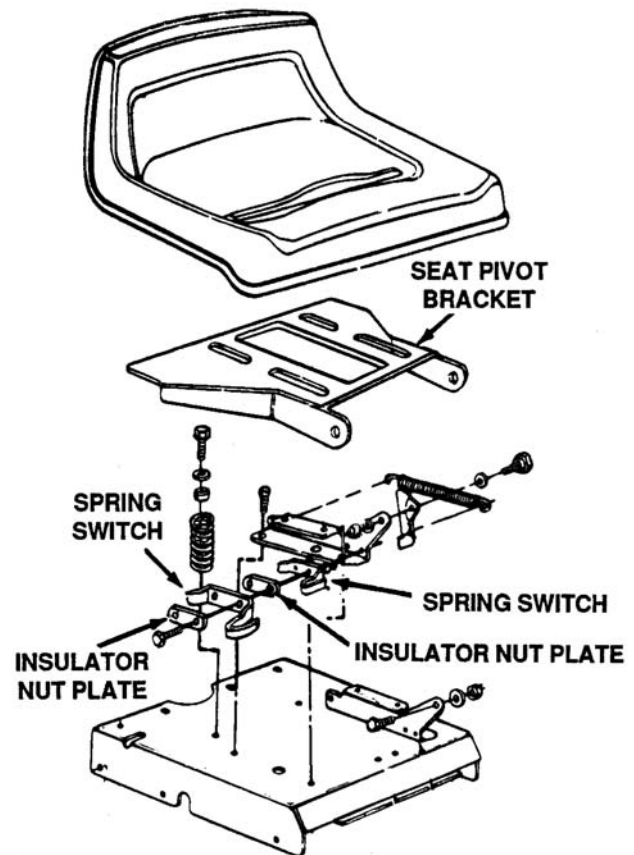


Figure 3-1. Operator Present Safety Seat

## 3.2 SAFETY INTERLOCK SYSTEM – CHANGES FOR 1991.



### NOTE

The safety interlock system for 1991 has some changes that may or may not retrofit prior production units.



### WARNING

At no time should the safety interlock system be bypassed for consumer's operation or convenience.

### 3-2.1 600 Series Rider Only.

1. The PTO safety switch mounting bracket was changed for added support to 14 gauge steel. This will retrofit 1990 production units. See Figure 3-2.

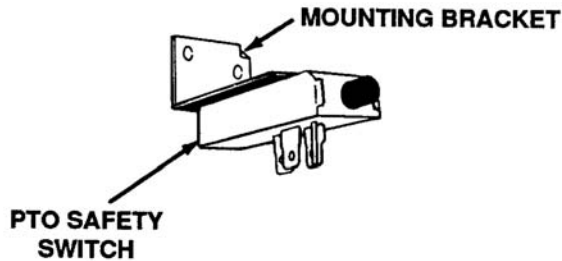


Figure 3-2. Mounting Bracket

2. The standard battery used in the 600 series is 725-0514 (125 cold cranking amps). This battery can now be replaced by part number 725-1430 (275 cold cranking amps) by removing the battery spring retainer to allow clearance for the larger battery. This will not retrofit prior production units. See Figure 3-3.

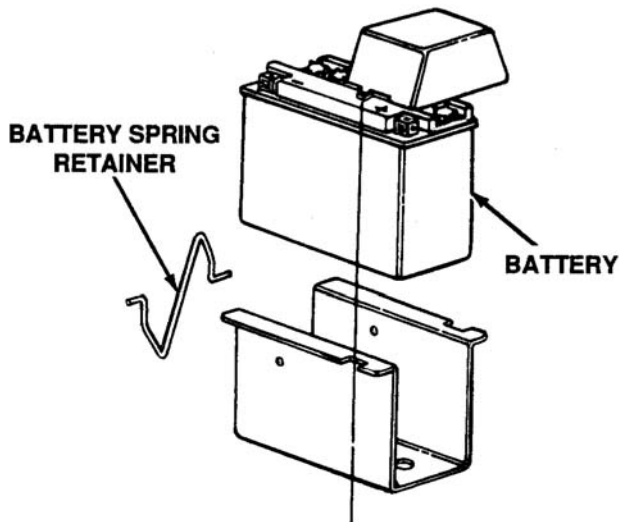


Figure 3-3. Battery With Spring Retainer.

3. Attach the steering wheel and indicator light panel as follows:
  - a. Place the indicator wires through the steering bellows and place the bellows over the steering shaft.
4. Place the indicator wires through the cable tie located on the bottom side of the steering wheel insert. Connect the wires to the corresponding wires in the steering wheel insert.

Tighten the cable tie on the insert to securely hold the wires in position.

5. Snap the steering wheel insert over the four spokes making sure the indicator lights are positioned towards the bottom.
6. Tighten the special cable tie in such a manner so the cable tie can slide up and down the wire harness which goes through the dash panel. (Slide the cable tie up until it rests against the hole on the inside of the dash panel.)
  - b. Place the five wires through the slotted hole located towards the center of the steering wheel hub. With the front wheels positioned straight forward, place the steering wheel over the steering shaft. Secure with the cupped washer and lock nut provided in the screw-pack. See Figure 3-4.

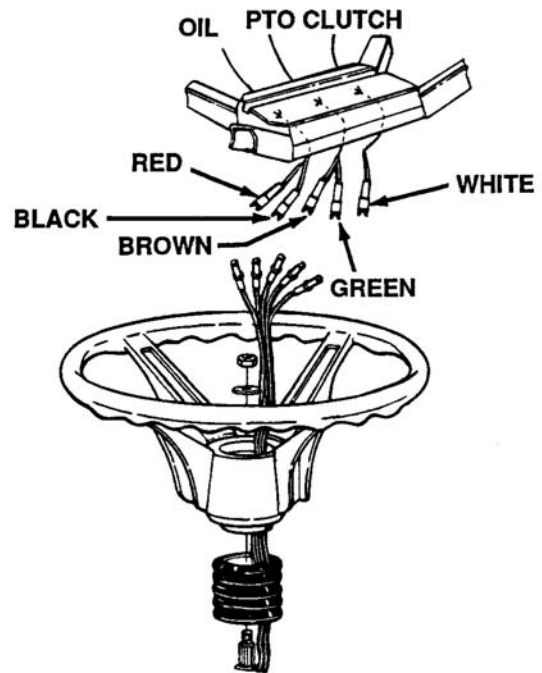


Figure 3-4. Steering Wheel

#### NOTE

The indicator wires should be positioned at the bottom of the steering wheel (6 o'clock position).



#### CAUTION

Do not cut off excess cable tie. The excess end will help keep the harness from being drawn up into the steering wheel and causing serious damage to the wires.

- Turn the steering wheel fully in both directions. Pull the wires down from the dash and slide the cable tie down an additional 1/4 inch and tighten the cable tie securely. While doing this procedure the cable tie will automatically position itself on the harness to prevent damage to the wires during normal operation.

### 3-2.2 All Riders and Tractors.

- The clutch safety switch has a retainer bracket for added support. This will retrofit 1990 production units. See Figure 3-5.

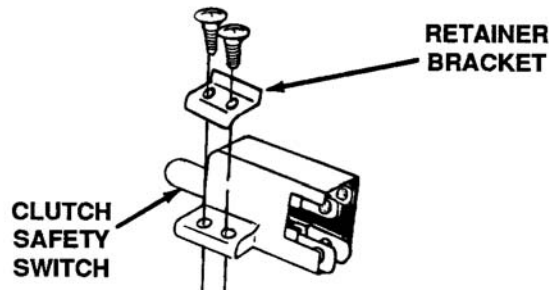


Figure 3-5. Retainer Bracket

#### NOTE

If the clutch safety switch (part number 725-3169A) is ordered, it will NOT come with the retainer bracket or screws. To retrofit to a pre 1991 production unit, it is necessary to order the retaining bracket (part number 179162) and two screws (part number 710-0351).

- The seat safety switch insulator nut plates have been redesigned to reduce the chances of a direct short. This will retrofit 1990 production units. See Figure 3-6.

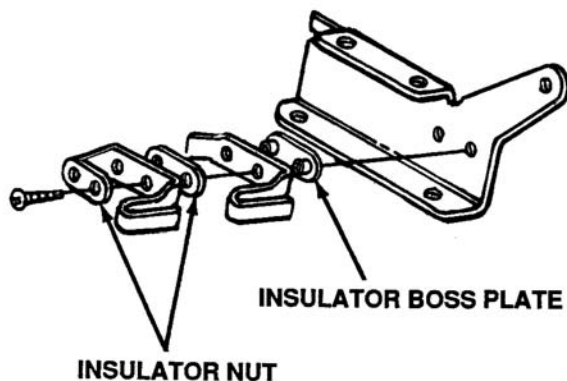


Figure 3-6. Safety Switch Insulator Nut Plates

#### NOTE

This boss plate goes all the way through the two spring switches and will reduce the chances of a short. This also will retrofit prior production units.

- 600, 700 and 800 Series Only.** The circuit breaker is being replaced by a standard automotive type fuse. Nonregulated electrical systems will use a 7-1/2 amp fuse. On regulated electrical systems, a 20 amp fuse will be used. This will not retrofit prior production units. See Figure 3-7.

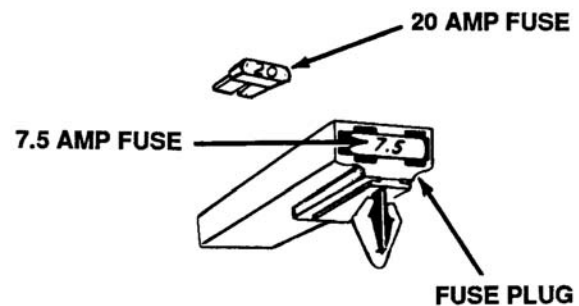


Figure 3-7. Fuse Holder

#### NOTE

Although this will not retrofit our prior production units, there are, however, two separate fuses: the 7.5 amp fuse for a standard dual circuit alternating system and the 20 amp fuse for a regulated system.

### 3-3. ELECTRIC START SYSTEM.

- Before the engine will crank, the key must be turned on and both of the safety switches must be activated. One is activated when the clutch is depressed and one is activated when the blade is disengaged. When this happens the circuit will be complete between the battery and the coil primary of the solenoid. This will close the solenoid which will allow the starter motor to crank the engine. The safety switches are wired in series on the electric start models. See Figure 3-8.

#### 3-3.2 Testing the Interlock System on the Electric Start System.

- Starting instructions:
  - Disengaged the blade or PTO.
  - Depress the clutch pedal.
  - Set the throttle (and choke if separate).
  - Turn the ignition key to the START position.



**➔ NOTE**

If the engine does not crank, use the following procedure to check out the system. If the engine cranks but does not start, the problem is not with the interlock system.

2. Check the two safety switches to see that the disengaging of the blade and the depressing of the clutch depresses the black plunger a minimum of 1/8 inch.
3. Check the fuse or circuit breaker between the positive terminal of the battery and the ignition switch. If the fuse or circuit breaker is blown the engine will not crank.
4. Check the following terminal to see that the wires are in place.
  - a. The positive terminal of the battery. A large and a small wire should be fastened
  - b. The negative terminal on the battery and the ground to the frame.
  - c. The ignition switch terminal.
  - d. The clutch safety switch.
  - e. The blade safety switch.
  - f. The solenoid terminals. A small wire is fastened to the coil primary and the two larger wires are fastened to each side.
5. Check the condition of your battery. Even if the battery is dead you should be able to hear the solenoid click. This would verify that the starting system is operating at least to the solenoid. The specific gravity of the battery should be 1.265.

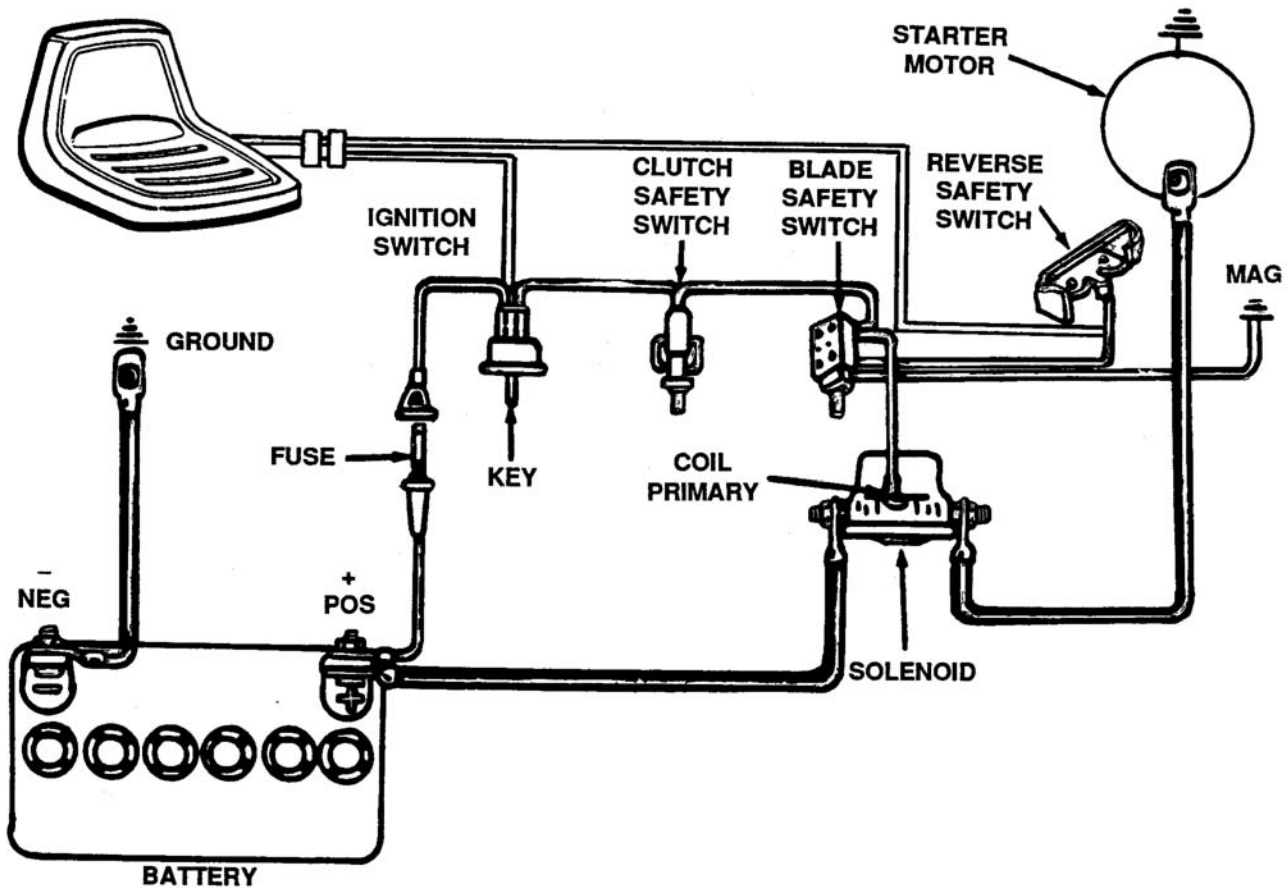


Figure 3-8. Typical Electric Start System

6. A continuity tester can be used to check the continuity between each component of the inter-lock system. Follow the instructions packed with the continuity tester which can be purchased at electrical shops.



#### WARNING

To test the interlock system further, you will be bypassing the safety switches. Make sure that the clutch is disengaged and the blade engagement lever is in the disengaged position. If the clutch cannot be locked in the disengaged position, place the gear shift lever in the neutral (N) position. When using a jumper wire in the following tests the engine may crank over.



#### NOTE

Disconnect the spark plug lead and ground it against the engine block

7. Use a jumper wire between the following points:
  - a. The positive terminal on the battery to the terminal on the solenoid (coil primary). If the engine cranks, then test within this circuit to find the exact area of the problem. See steps b and c below.
  - b. The positive terminal of the battery and the S terminal on the ignition switch. If the engine cranks, the problem is between the battery and the ignition switch.
  - c. The S terminal on the ignition switch to the coil primary terminal on the solenoid. If the engine cranks, the problem is between the ignition switch and the solenoid.
  - d. Jump between the two large terminals on the solenoid.

- 3-3.3 Testing the Safety Reverse Switch on the Electric Start Systems.** If the engine can be started, but stalls when the blade is engaged, use the following procedure to determine if the problem is in the reverse safety switch:



#### NOTE

Only use a wire as heavy as the wire from the solenoid to the starter with an alligator clip. If you have current up to the coil primary terminal of the solenoid and the starter will not

crank, however, you can crank the starter using the jumper wire, the problem is with the solenoid. Check the base of the solenoid to see that it has a good ground to the frame of the unit. If it still fails to operate, replace it.



#### NOTE

Transmission lever must not be touching the reverse spring switch and the key must be in the ON position.

1. Disconnect the yellow wire going to the magneto on the engine.
2. Disconnect the wire attached to the spring switch.
3. Attach one lead of a continuity tester to the spring switch and the other lead to ground. If there is continuity, the fiber washers could be damaged and should be replaced.

#### 3-3.4 Testing the Solenoid on Electric Start Riders and Tractors.



#### NOTE

Through examination of returned warranty parts, we have found instances of solenoids being replaced unnecessarily on electric start riders.

1. The following are real solenoid problems and require replacement of the solenoid:
  - a. Solenoid is stuck – Unit will start with ignition key in OFF position.
  - b. Coil wire (inside solenoid) is bad – Solenoid will not function.
  - c. Bad washer (inside solenoid) – Solenoid clicks but starter motor does not turn.
2. Other problems which can appear to be a defective solenoid:
  - a. Faulty ground.
  - b. Defective safety switch.
  - c. Discharged battery.
  - d. Defective starter motor.
  - e. Blown circuit breaker.

f. Defective ignition switch.

g. Defective wire harness.

1. Coil Check:

a. Disconnect the spark plug wire from the spark plug.

b. Disconnect the coil wire from the solenoid.

c. Using a DVOM (in the OHMS setting) attach the red lead to the coil connection and the black lead to system ground.

d. The resistance reading should be about 5 ohms.

\*Meter readings greater than 10 ohms or less than 3 ohms indicates solenoid failure.

e. Remove meter leads and reconnect coil wire.

2. Contact Check:

a. Disconnect the spark plug wire from the spark plug.

b. Disconnect the wire AT THE STARTER which runs to the solenoid.

c. Using a DVOM (in the OHMS setting), attached the red lead to a contact bolt and the black lead to the other contact bolt.

The meter should read "OPEN" circuit, or infinity.

\*A "closed" circuit indicates solenoid failure.

d. Energize the solenoid using the start switch. **WARNING: DO NOT HOLD "ON" FOR MORE THAN 5 SECONDS AT A TIME.**

e. The meter should read "CLOSED" circuit, or less than 10 ohms.

\*An "OPEN" circuit indicates solenoid failure.

f. Remove meter leads and reconnect the starter wire.

**3-4. RECOIL START SYSTEM.**

3-4.1 The recoil start system is completely different than the electric start system. If the clutch is not depressed (disengaged) the blade is not disengaged or the ignition key is not ON, the ignition will be disabled and the engine cannot be started. In order for the blades and clutch to be engaged without killing the engine, you must insert the recoil starter handle into the dash panel and turn it a quarter turn. This will disengage the wire that grounds the magneto. The safety switches are wired in parallel on the recoil start models. See Figure 3-9.

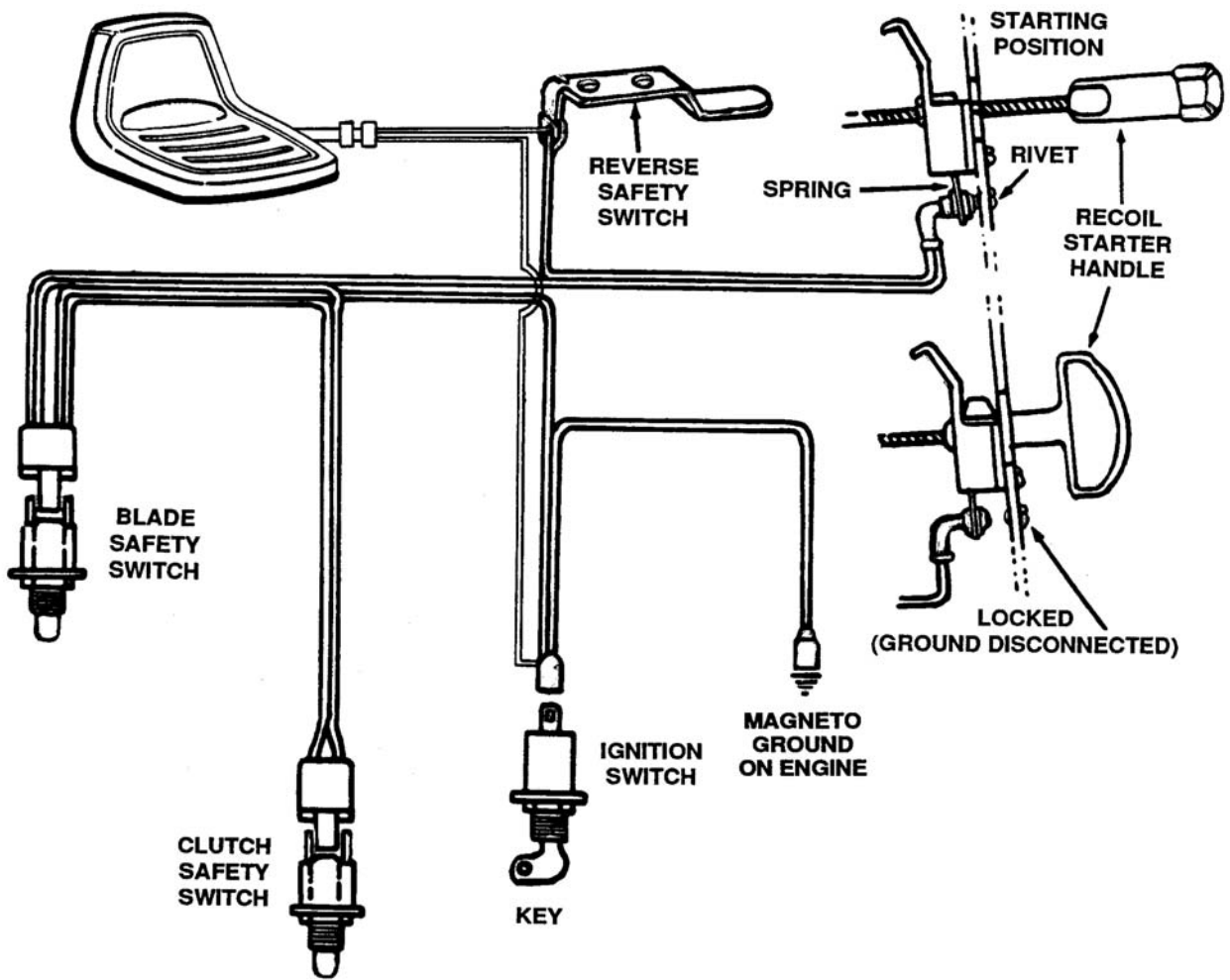


Figure 3-9. Typical Recoil Start System

3-4.2 Pushing the plunger in breaks the contact of the circuit. The red or white plunger identifies the switch as being the correct one to use on the recoil start models. See Figure 3-10.

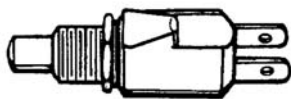


Figure 3-10. Plunger

5 -4. If the engine will not start and the gasoline shut-off valve is open, there is fuel in the gasoline tank and the spark plug wire is attached, use the following procedure to determine if the problem is in the engine or the safety interlock system:

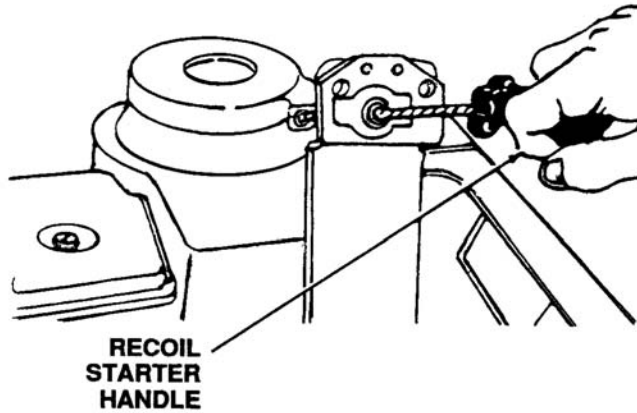
1. Check the two interlock switches to see that the disengaging of the blade and the depressing of the clutch pedal depresses the red plunger a minimum of 1/8 inch.

2. Disconnect the yellow wire from the ignition switch to the engine where it attaches to the primary wire from the breaker assembly.
3. If the engine starts now, the problem is within the interlock system.
4. Check the grounding system behind the recoil starter handle. When the recoil starter handle is being pulled, the bolt on the spring should be grounded against the rivet. When the recoil starter handle is locked in place, the bolt on the spring should not touch the rivet.

**3-4.3 Testing the Interlock System on the Recoil Start System.**

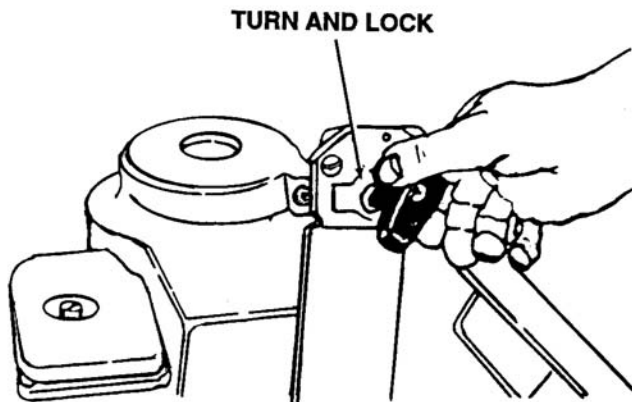
1. Start the engine as follows:
  - a. Disengage the blade.
  - b. Depress the clutch pedal and lock it in the disengaged position.

- c. Set the throttle control.
- d. Turn the ignition key to the ON position.
- e. Grasp the recoil starter handle and unlock it by twisting it 1/4 turn. Pull out sharply and hold it in the out position. See Figure 3-11.



**Figure 3-11. Recoil Starter Handle**

- f. Slowly let it rewind and pull it out again if the engine does not start.
- g. After the engine starts, slowly let the recoil starter handle rewind and lock it into the dashboard by turning it a quarter turn. See Figure 3-12.



**Figure 3-12. Locking Recoil Starter Handle**



**WARNING**

To determine if the problem is in the engine or interlock system, it is necessary to make the mower unsafe by bypassing the safety switches. Use extreme caution in performing these tests.



**WARNING**

The engine can no longer be shut off with the key.

2. Disassembly procedure. Disassemble safety seat as follows:
  - a. Remove molding clip on lower front of seat. Remove molding.
  - b. Remove seat covering and foam padding.

**3-4.5 Testing the Safety Reverse Switch on Recoil Start Systems.** If the engine can be started, but stalls when the blade is engaged, use the following procedure to determine if the problem is in the reverse switch:

1. Disconnect the yellow wire going to the magneto on the engine.
2. Disconnect the wire attached to the spring switch.
3. Attach one lead of a continuity tester to the spring switch and the other lead to ground. If there is continuity, the fiber washers could be damaged and should be replaced.

**3-4.6 Testing Procedure for Operator Present System (Safety Seat).**

1. To check the operation of the safety seat, proceed as follows:
  - a. Start the unit as instructed in the owner's guide.
  - b. Set the parking brake.
  - c. Place shift lever in neutral gear.
  - d. Engage the PTO or blades.
  - e. Raise up off seat (this will activate the seat kill mechanism).



**WARNING**

The recoil start system is not a fail-safe system. When a wire becomes unplugged from any component, it does not prevent starting as the electric start system does. If the engine can be started with either the clutch or blade engaged or with the ignition key in the OFF

position, the unit should not be returned to the customer.

**NOTE**

The transmission lever must not be touching the reverse spring switch and the key must be in the ON position.

At this point the engine should stop running. If unit continues to run, check wire lead and seat plug for proper connection. If this connection is satisfactory, then the seat switch mechanism and wire lead continuity should be inspected for shorts in the electrical system. See Table 3-1.

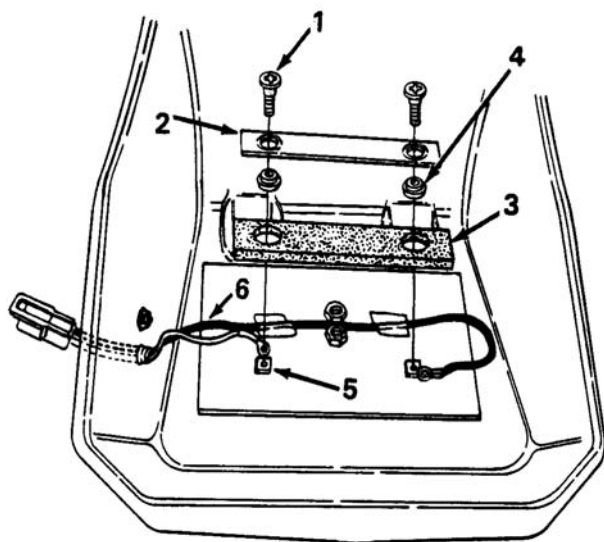


Table 3-1. Safety Seat Electrical System

REF. NO.	PART NO.	DESCRIPTION	QTY.
1	738-0706	Shoulder Screw	2
2	16561	Seat Switch Base	1
3	731-0833	Foam Seat Switch	1
4	731-0822	Shoulder Spacer	2
5	731-0830	Push-In Nut	2
6	725-1218	Wire Harness	1

2. Disassembly procedure. Disassemble safety seat as follows:

- a. Remove molding clip on lower front of seat. Remove molding.
- b. Remove seat covering and foam padding.

**NOTE**

Covering and padding are bonded together.

- c. Remove phillips head screws, metal plate, bushings and foam pad. See Figure 3-13.

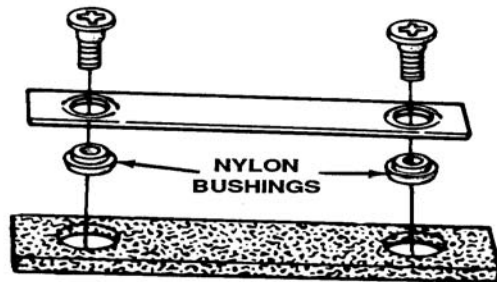


Figure 3-13. Safety Seat Disassembly

**NOTE**

When reassembling, note the position of nylon bushings. Shoulder of bushing must be placed upward through plate.

- d. Check for broken terminal end or frayed plug wire tape to the bottom of the seat pan.
3. Assemble seat in reverse order. Once assembled, check by pushing downward on metal plate. Distance between metal plate and phillips head screws must be maintained for proper switch operations.

**NOTE**

For 1988 production, the location and type of safety switch has been changed on most front engine lawn tractors. It is now mounted on the seat bracket under the seat. See Figure 3-14.

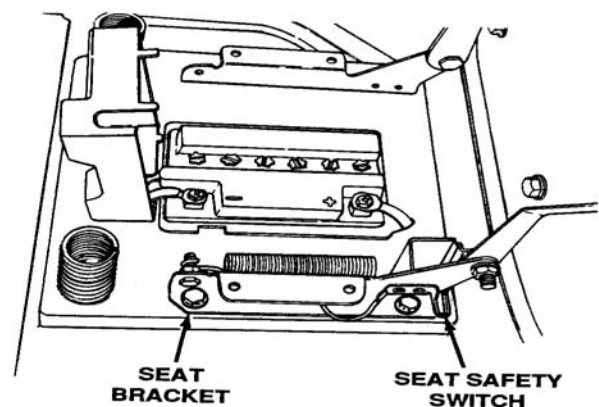
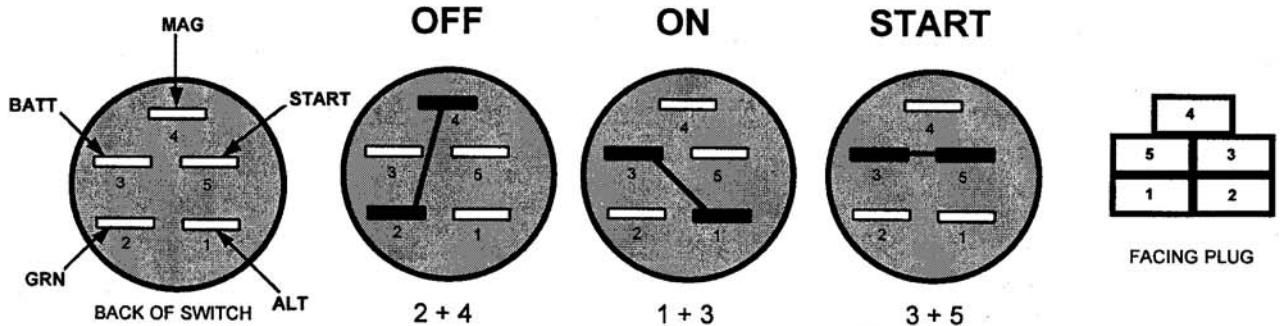
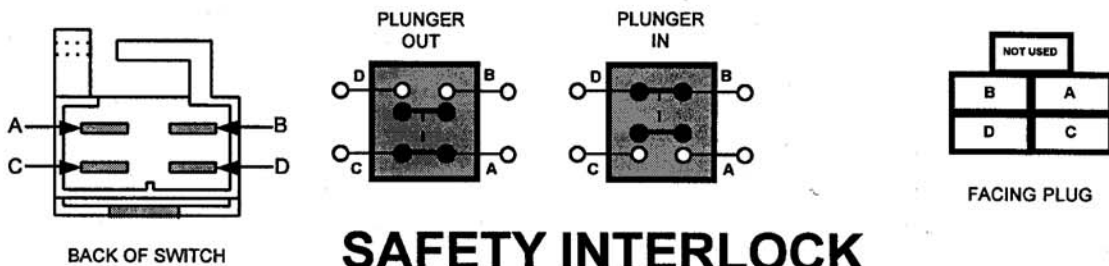


Figure 3-14. Safety Switch Location

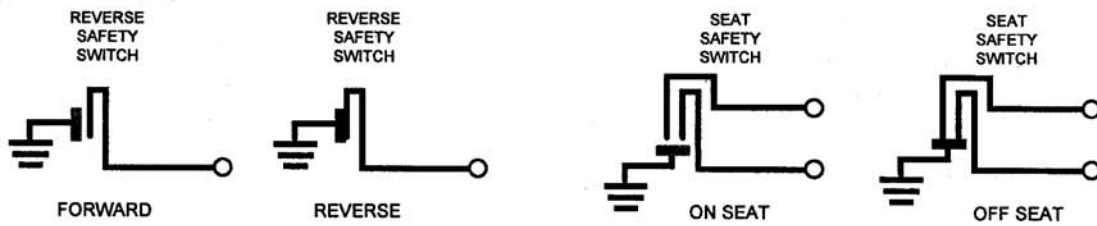
# Switch Configuration & Symbol Chart



**IGNITION SWITCH**  
**S20**

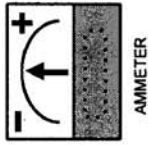
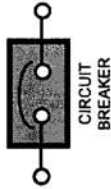
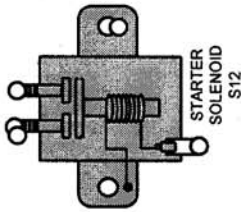
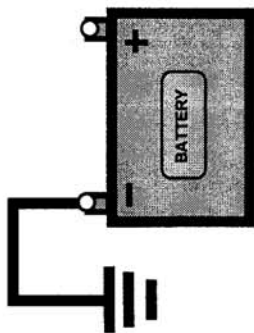
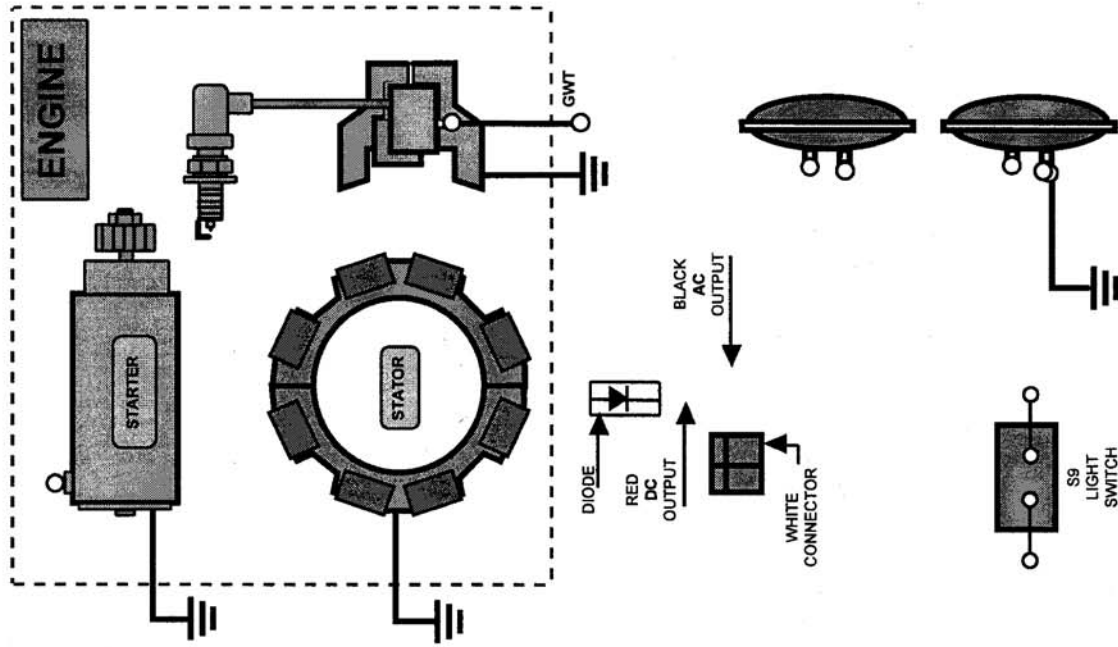


**SAFETY INTERLOCK**  
**S5**



**LIGHT SWITCH**  
**S9**

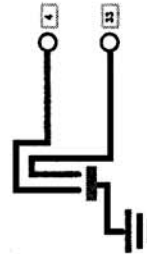
**MTD MODEL 300/400/600 SERIES**



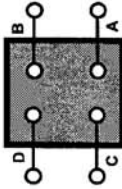
REVERSE SAFETY SWITCH



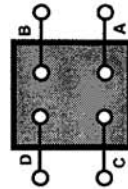
SEAT SAFETY SWITCH



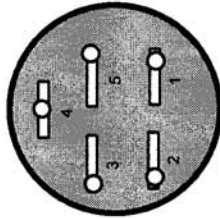
DECK INTERLOCK SWITCH



CLUTCH INTERLOCK SWITCH

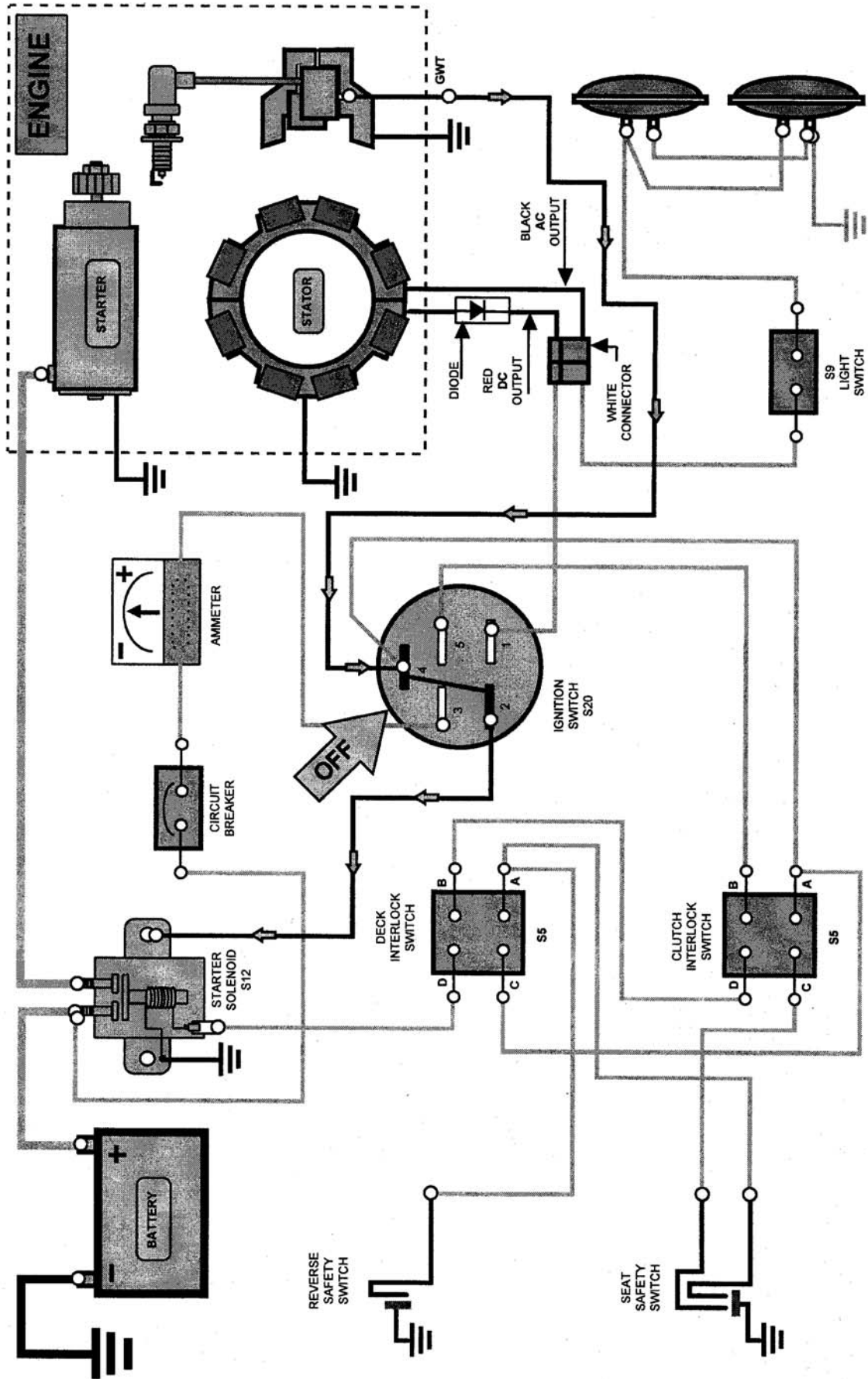


IGNITION SWITCH S20



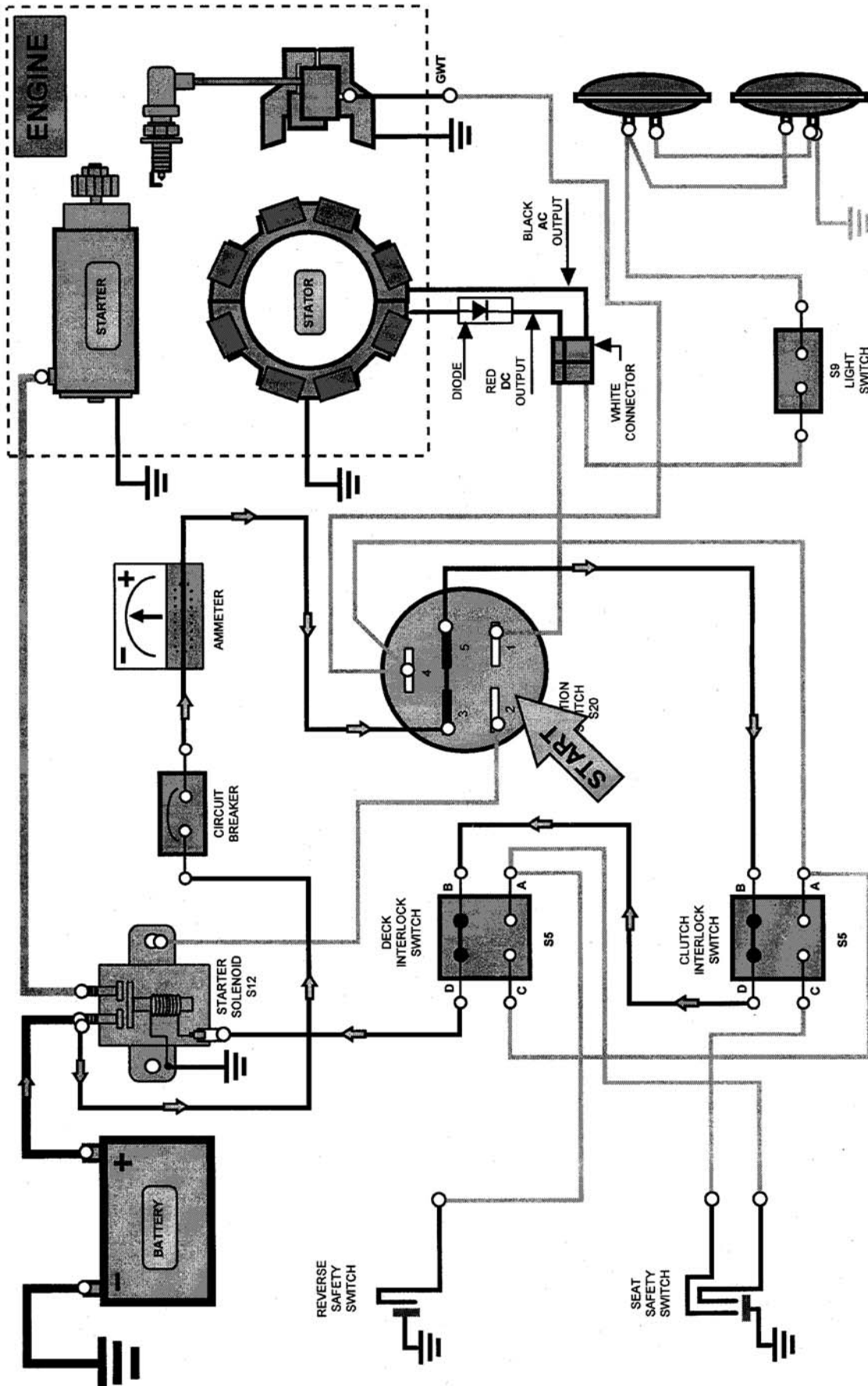
**MTD MODEL 300/400/600 SERIES**





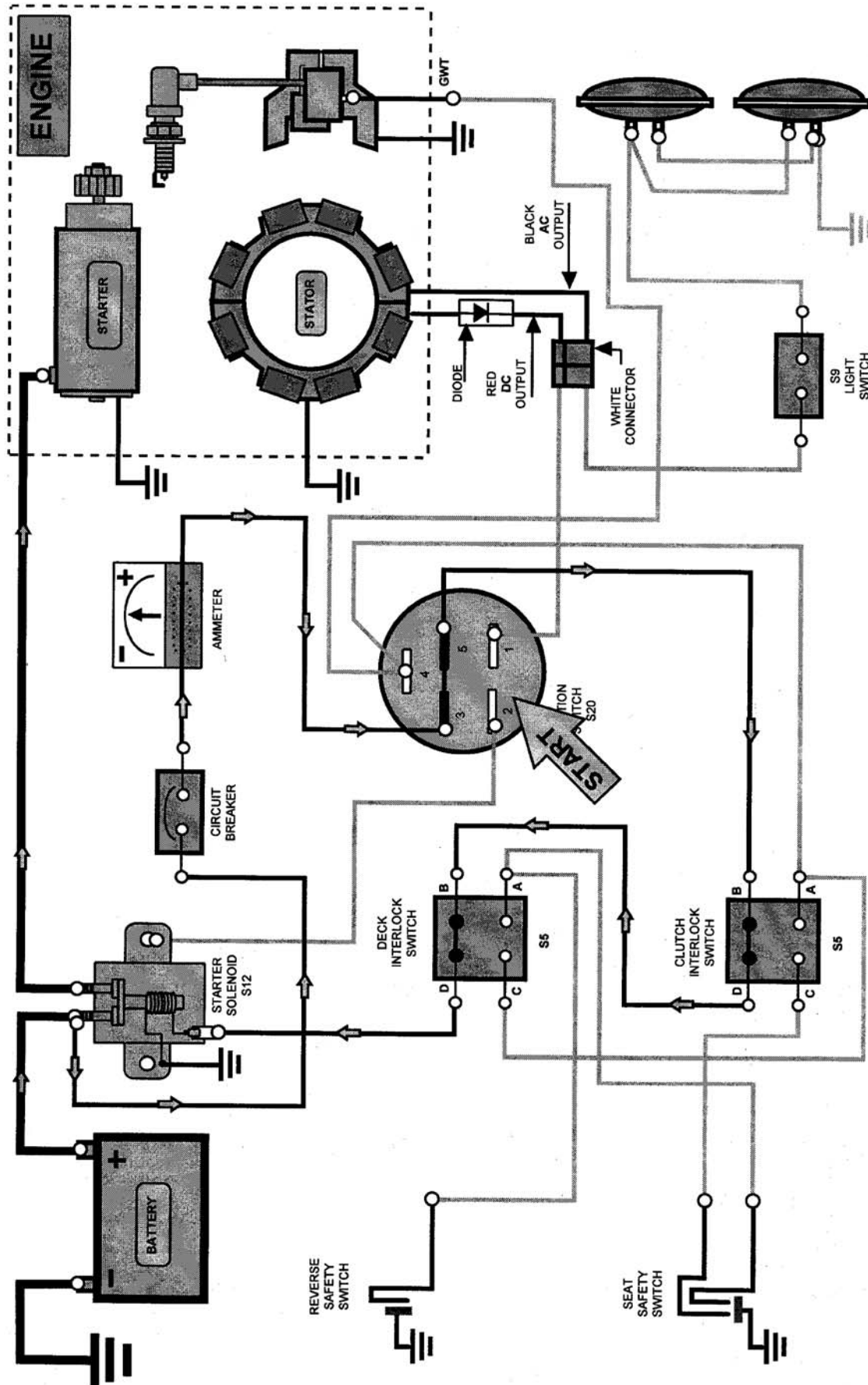
**IGNITION OFF**

**MTD MODEL 300/400/600 SERIES**

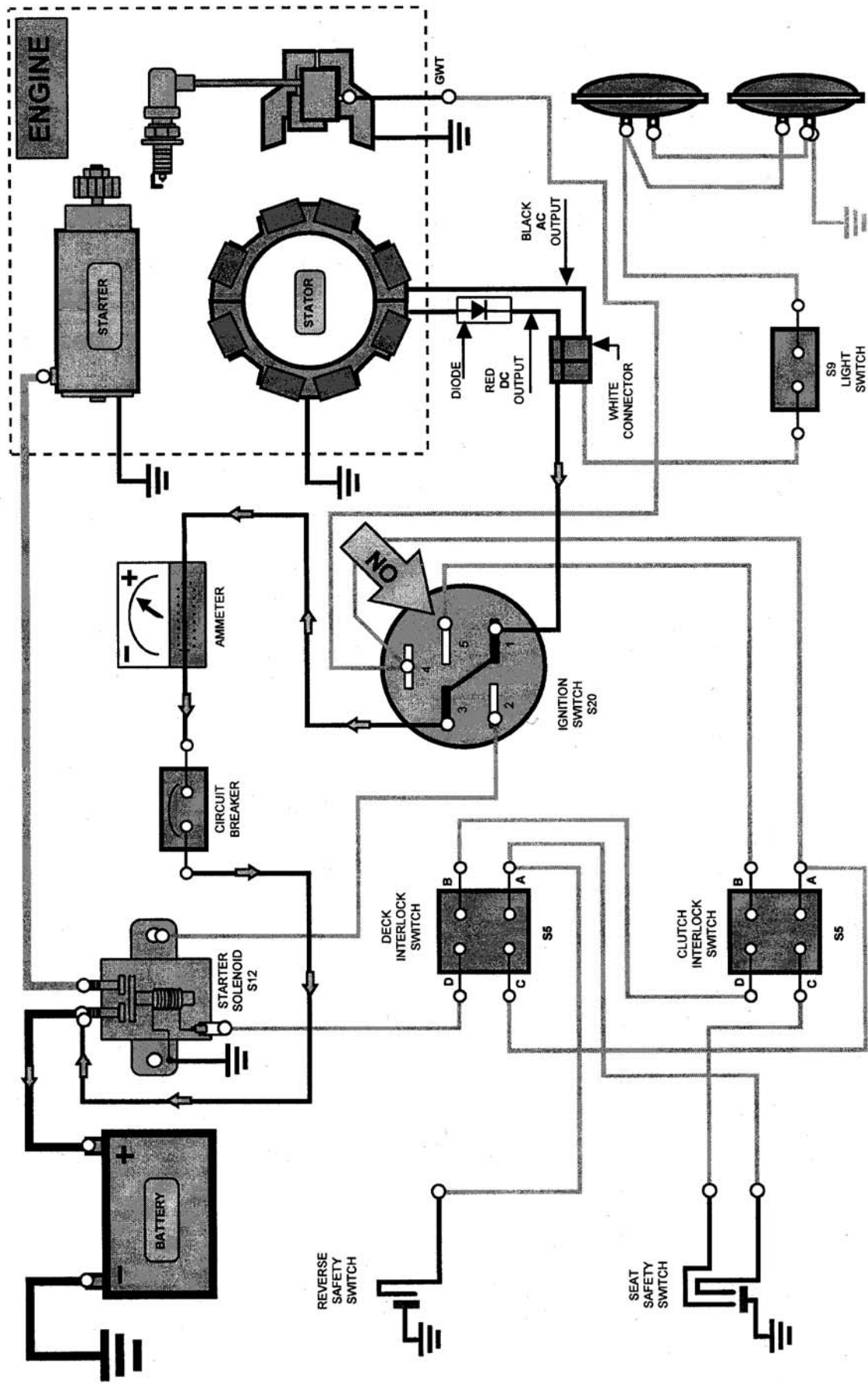


**MTD MODEL 300/400/600 SERIES**

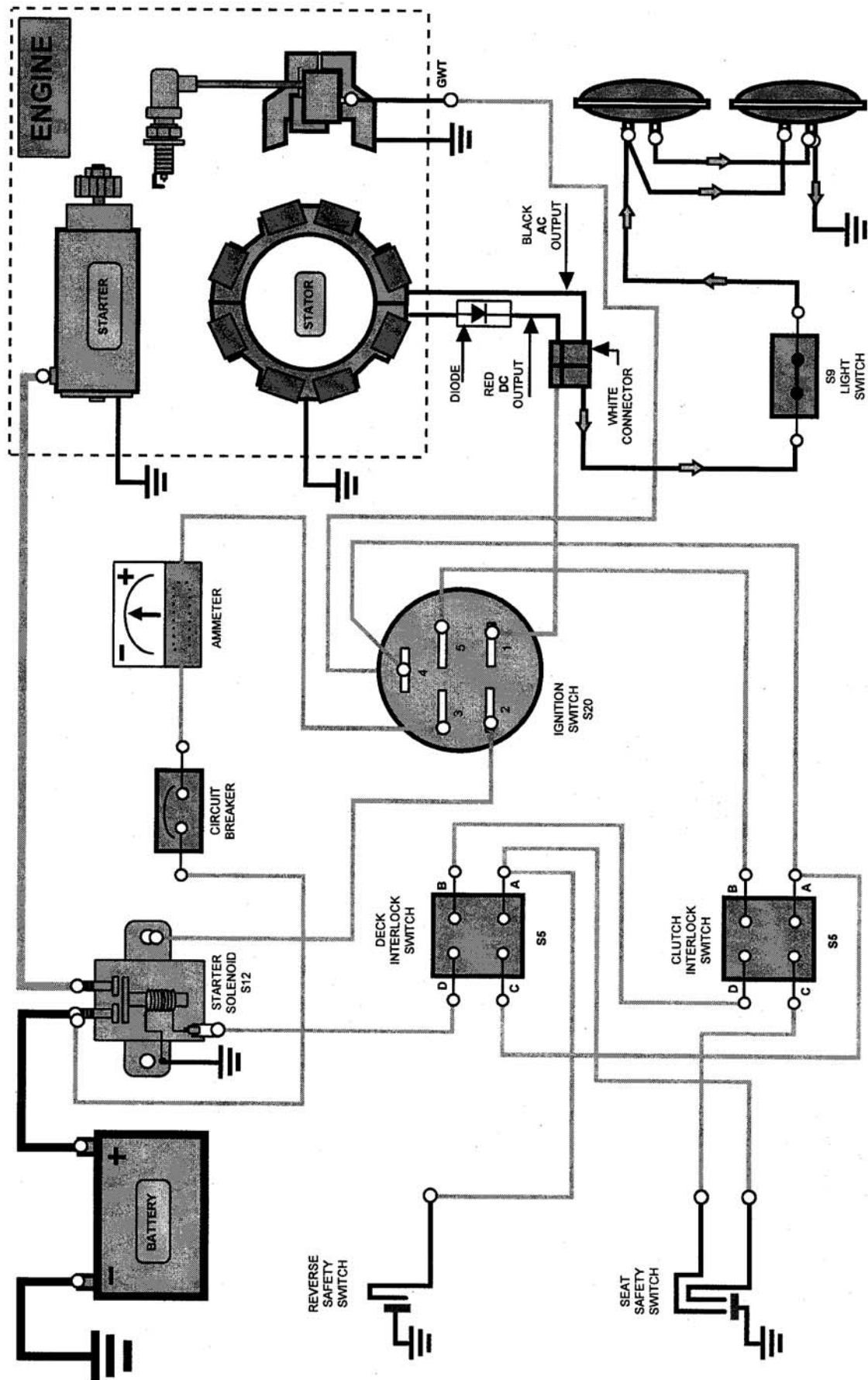
**STARTING 1**



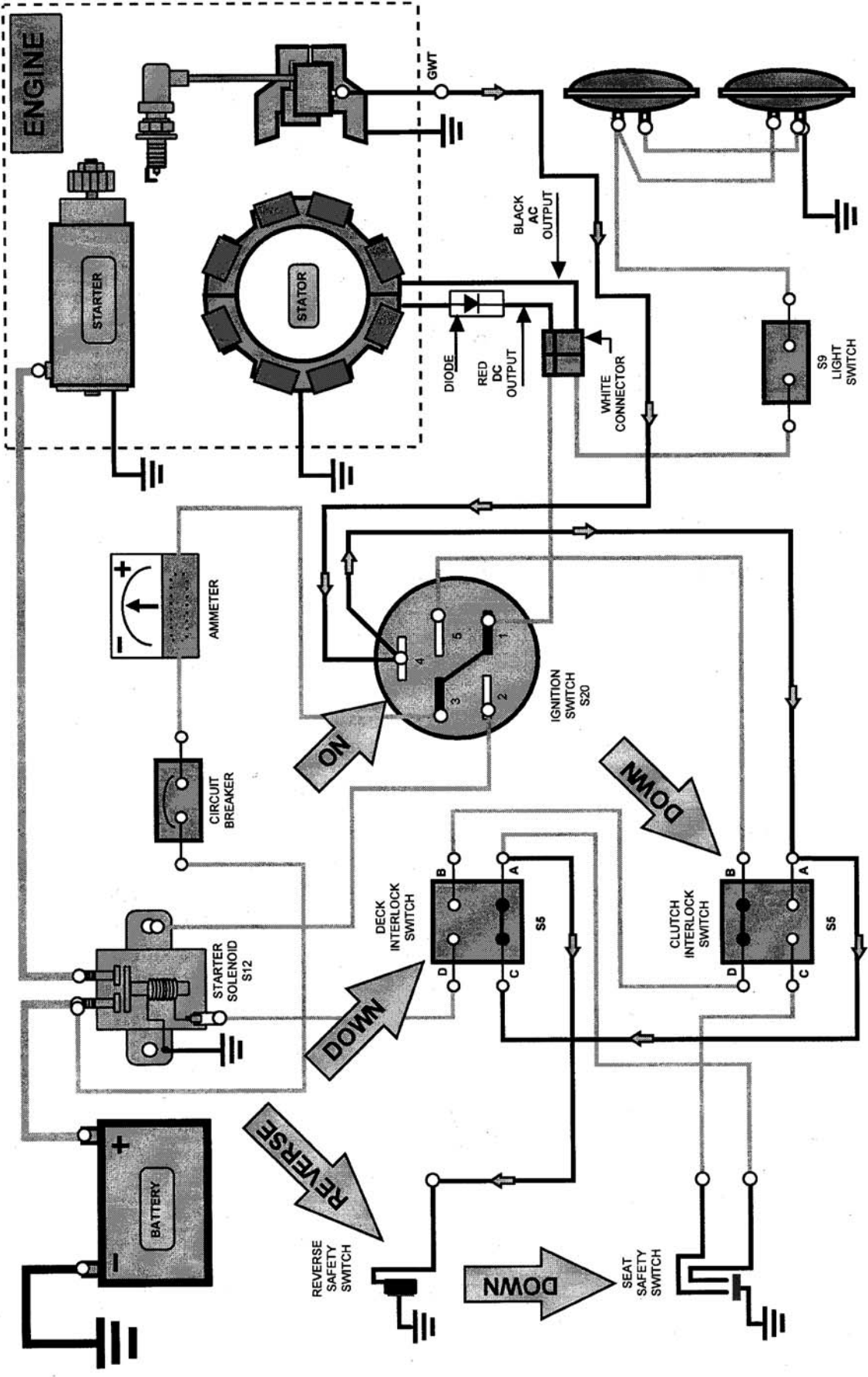
**MTD MODEL 300/400/600 SERIES STARTING 2**



**MTD MODEL 300/400/600 SERIES** **RUN/CHARGE**

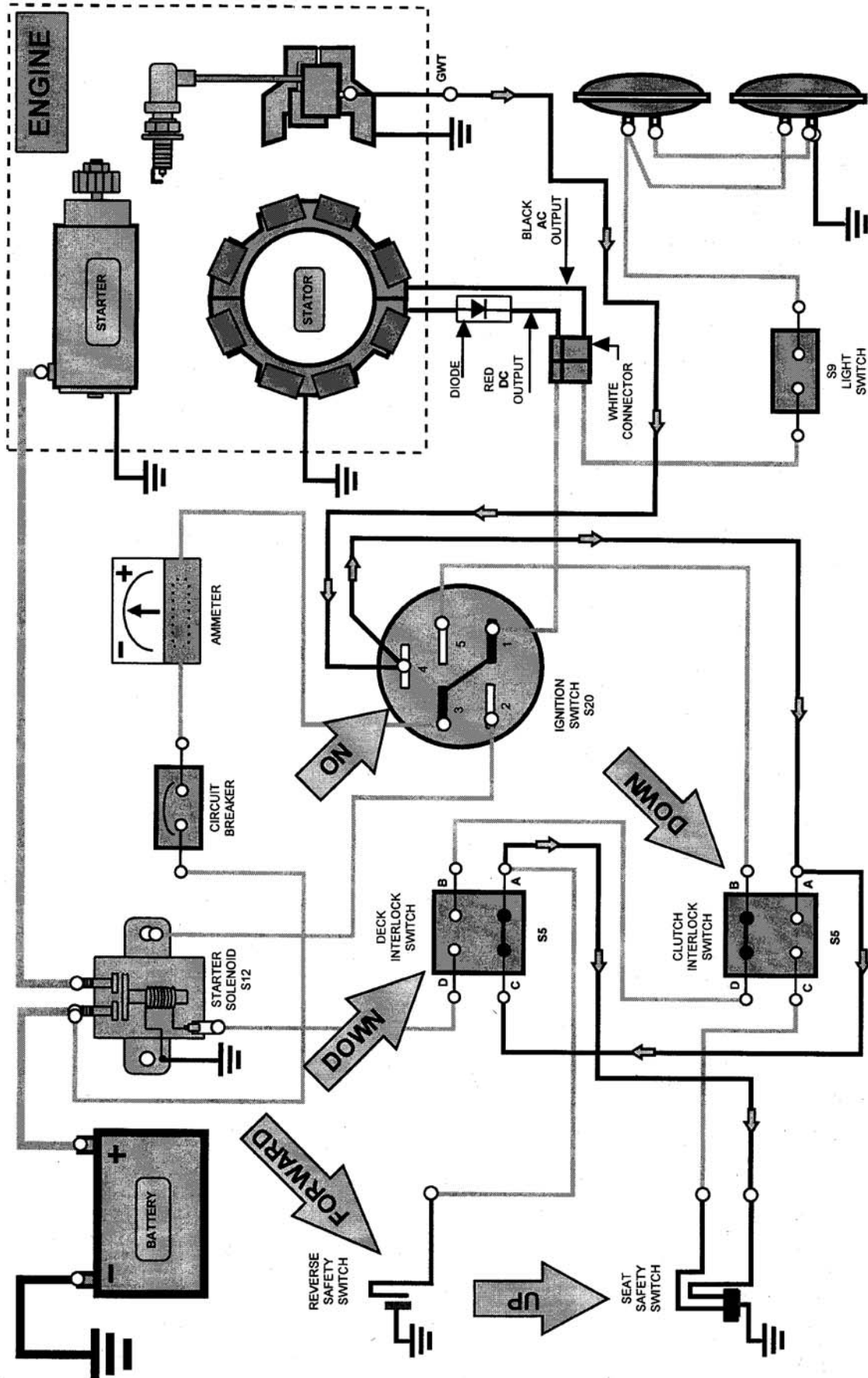


**MTD MODEL 300/400/600 SERIES LIGHTING**



**SAFETY/REVERSE**

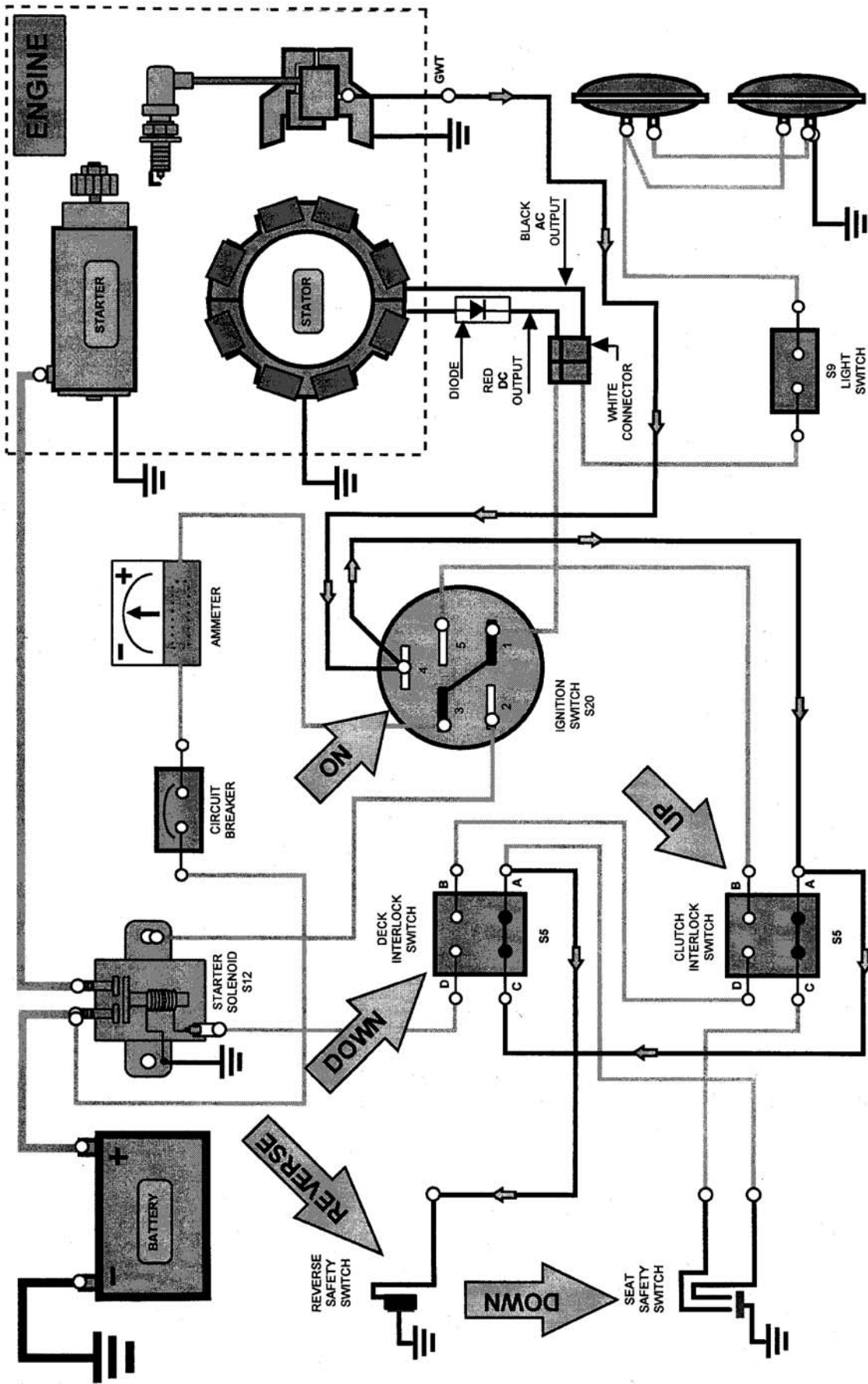
**MTD MODEL 300/400/600 SERIES**



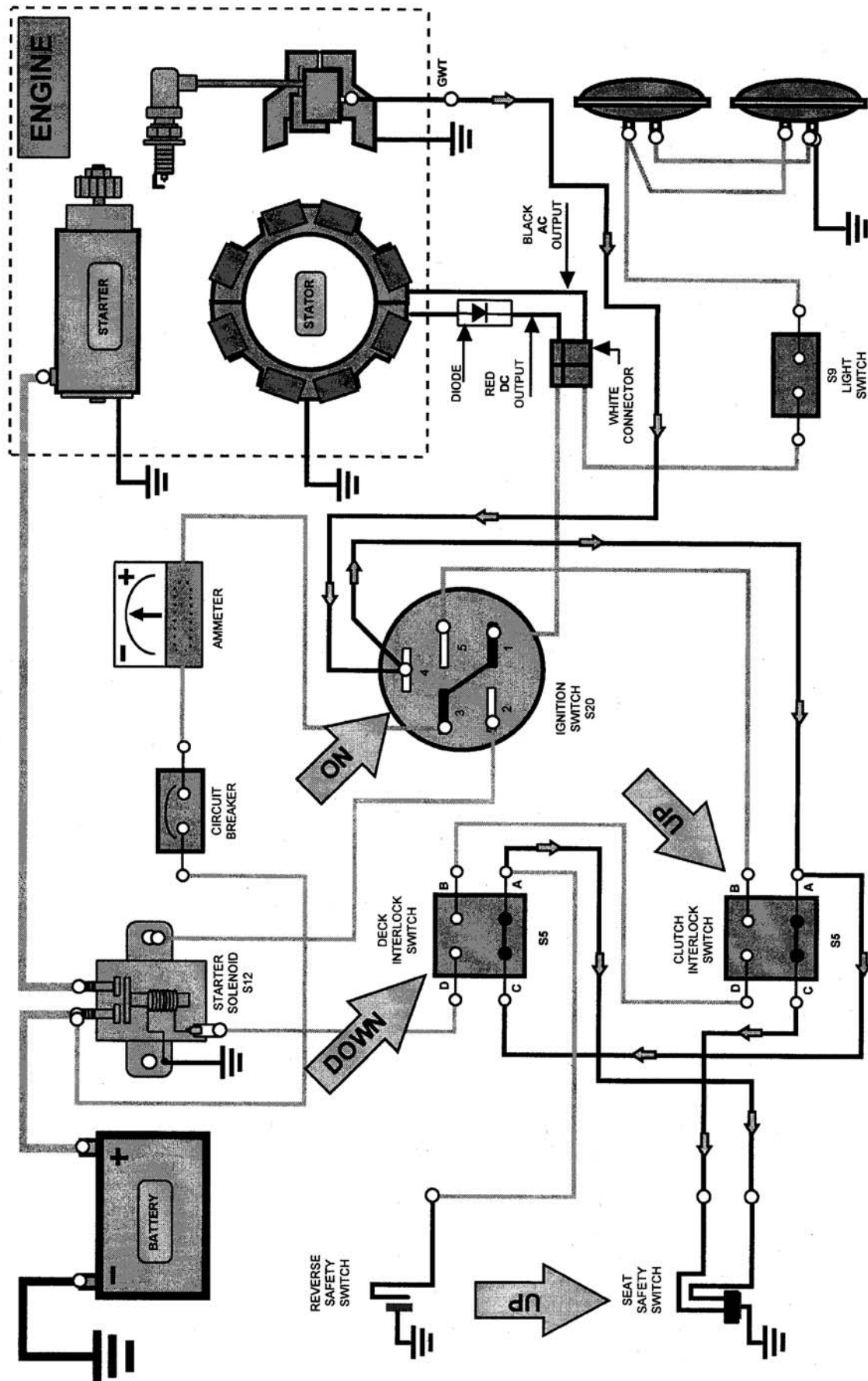
**SAFETY/SEAT**

**MTD MODEL 300/400/600 SERIES**

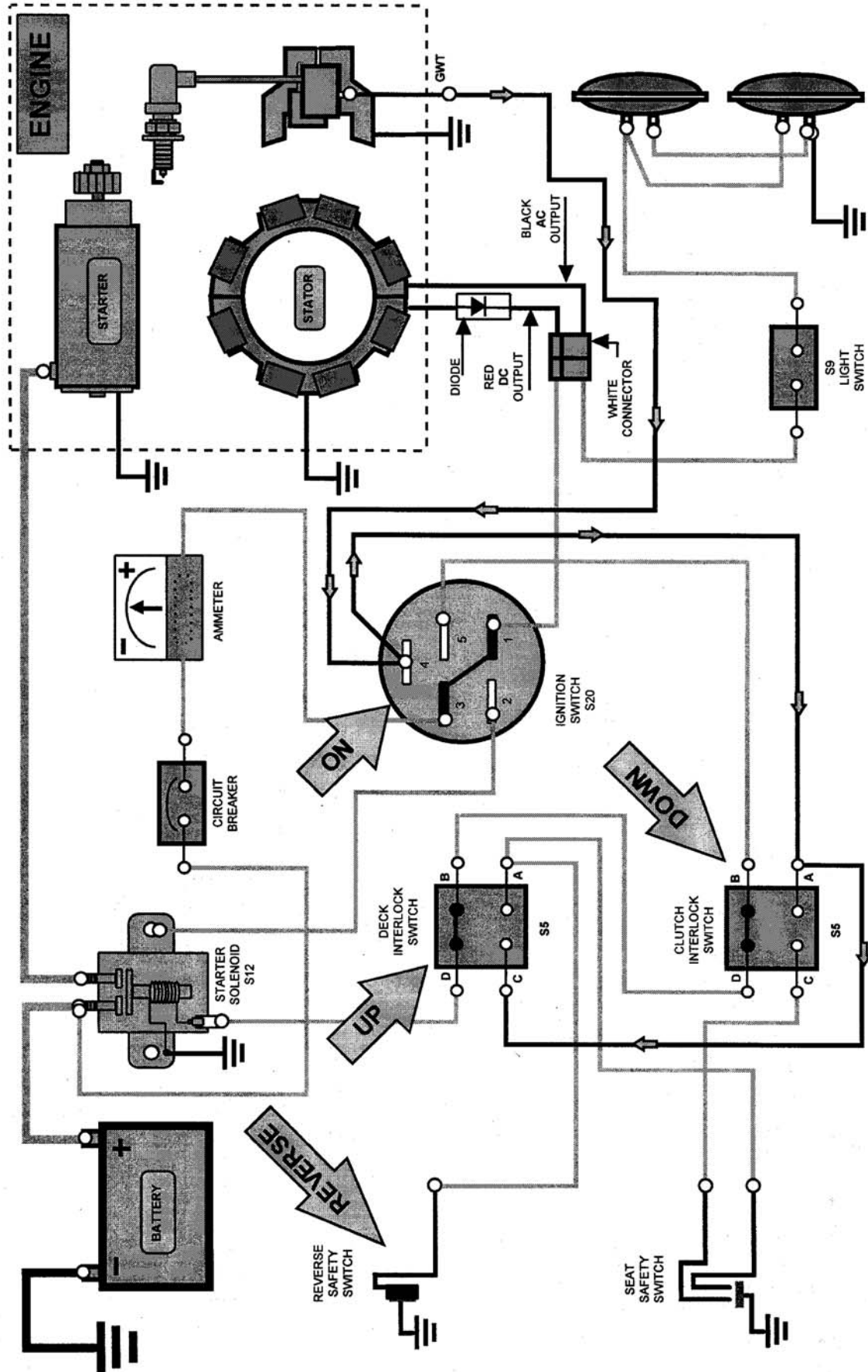






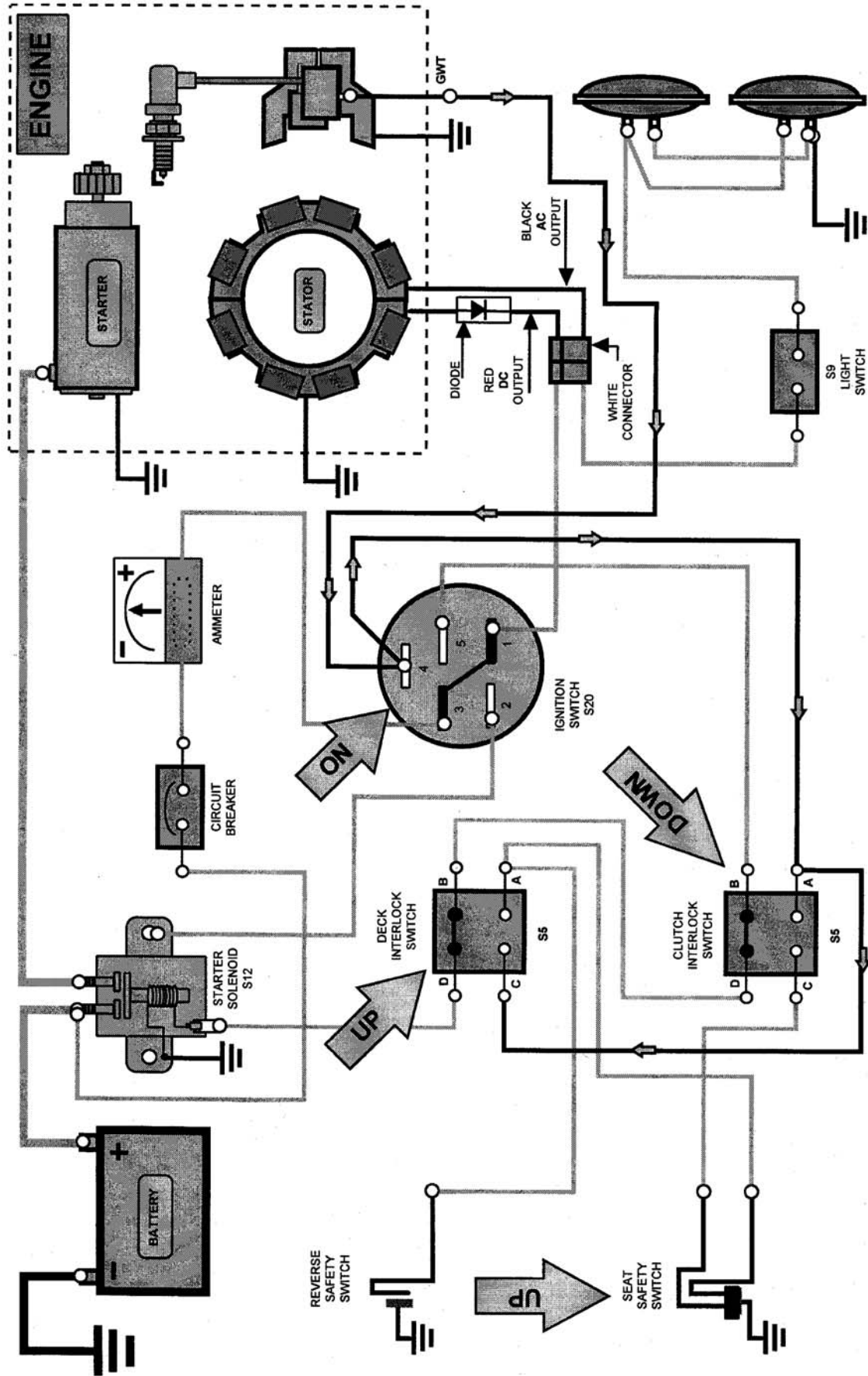


**MTD MODEL 300/400/600 SERIES SAFETY/CLUTCH**



**SAFETY/OK**

**MTD MODEL 300/400/600 SERIES**



**MTD MODEL 300/400/600 DUAL CIRCUIT SERIES SAFETY/OK**

### 3.5 TROUBLESHOOTING SAFETY INTERLOCK SYSTEMS.

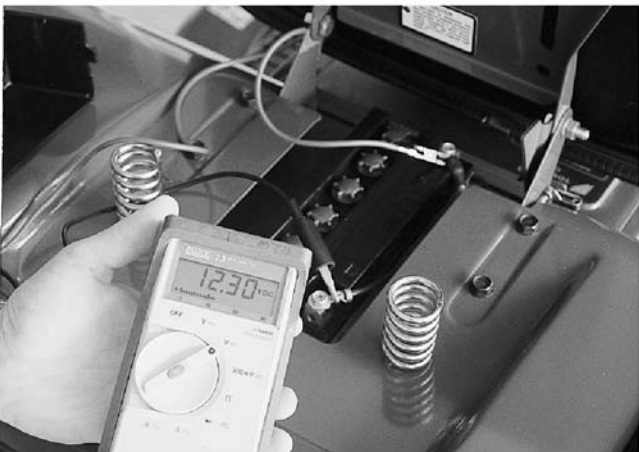
**Problem:** The engine will not crank.

1. Check the battery cables to be certain that they are connected properly. The black cable should be connected to the negative terminal on the battery. The red cable should be connected to the positive terminal on the battery. Connections must be tightened securely. See Figure 3-15.



**Figure 3-15.**

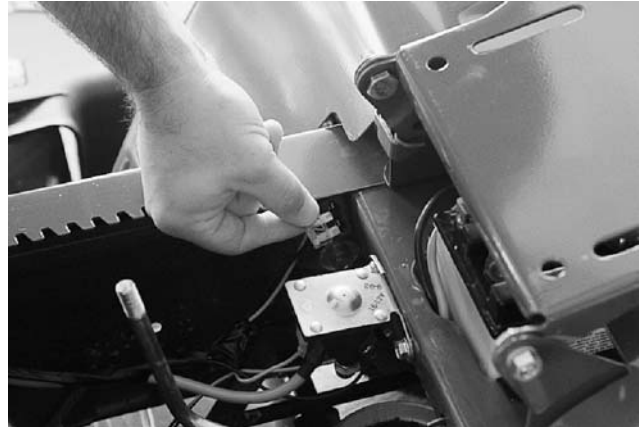
2. Check the battery with a voltage tester. The battery should read approximately 12 volts. Turn the key switch to the start position. If the voltage drops more than 2 volts, refer to the battery video for testing procedures. See Figure 3-16.



**Figure 3-16.**

3. Remove the shift panel to gain access to the solenoid and fuse.

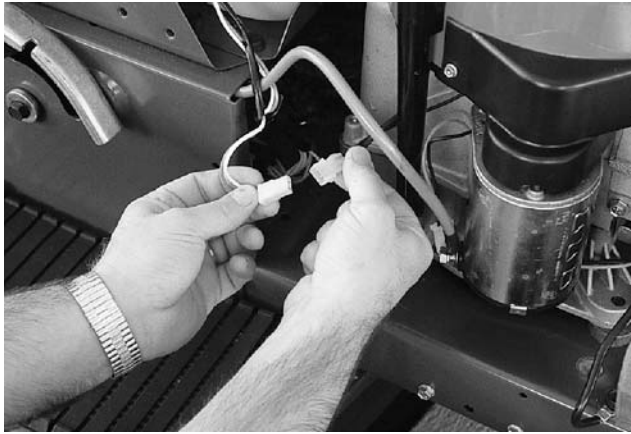
- a. Check for a tripped circuit breaker or blown fuse. Circuit breakers seldom open or fuses blow without a reason. The problem must be corrected. See Figure 3-17.



**Figure 3-17.**

- b. If your unit has a fuse, pull the fuse to determine if it has blown. If it has, you will have to find the fault.
  - c. To test a circuit breaker, connect a volt meter or a 12 volt test light between the negative battery terminal and each side of the circuit breaker terminals. If voltage is present at both terminals the breaker is good. If not, replace the breaker.
  - d. Check for a short in the wiring. A dead short may be in the cranking or charging circuit where the insulation may have rubbed through and exposed a bare wire. Replace the wire or repair with electrical tape if the wire strands have not been damaged.
  - e. Look for a wire pinched between body panels, burned by the exhaust pipe or muffler or rubbed against a moving part.
4. If your unit has a dual circuit alternator and the fuse is blowing or the breaker is tripping, check for proper wiring. If you have a regulated system disregard this section.

Disconnect the red and white lead connector which goes to the alternator. If the unit cranks, the wires are reversed and a dead short resulted. Reverse the wires to correct the problem. See Figure 3-18.



**Figure 3-18.**

**NOTE**

For more information on charging systems, see the video "Batteries and Charging Systems".

5. Check to be certain the small orange wire is connected to the small terminal on the solenoid. On some units, this wire may be red instead of orange.

Using a test light or meter, check for voltage at this wire with the key in the start position. If voltage is present, the key switch and safety circuits are O.K. but the solenoid must be checked further or replaced. See Figure 3-19.

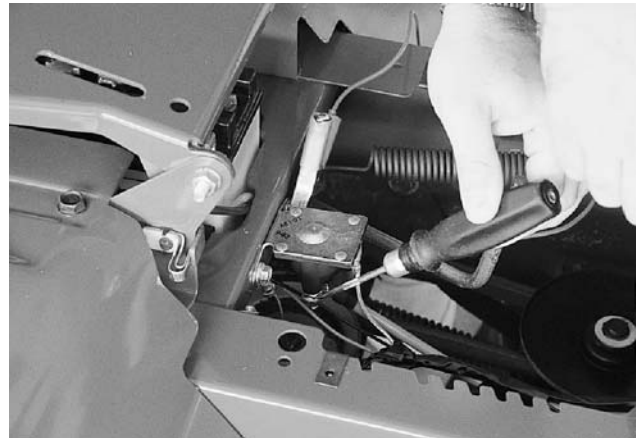


**Figure 3-19.**

6. Clamp the test light to the base of the solenoid. Touch other probe to the positive terminal of the solenoid. It should show voltage.
7. Touch probe to terminal on solenoid that goes to starter. Turn ignition key to the start position. If no voltage is present, replace the solenoid.

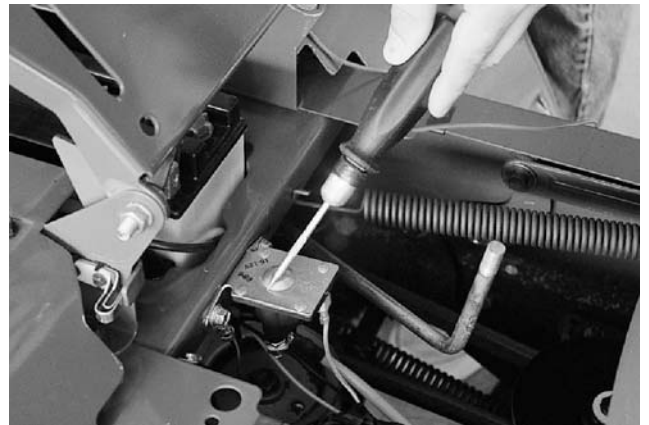
Check to be certain the unit is grounded properly. The black, or negative, cable coming from the battery must be properly secured to the frame or engine, depending on the model tractor.

8. To check for proper electrical ground, connect one side of your meter or test light to the positive terminal of the battery. Touch the other lead to the mounting bracket of the solenoid. If voltage is present, the solenoid is properly grounded. See Figure 3-20.



**Figure 3-20.**

Touch the other lead to the mounting bracket of the solenoid. If voltage is present, the solenoid is properly grounded. See Figure 3-21.



**Figure 3-21.**

If your unit has a small green wire to the base of the solenoid, make certain that it is securely connected.

9. The engine may have a ground wire located at the base of the engine, attached to the frame. It must be firmly attached to both the engine and the tractor frame. See Figure 3-22.

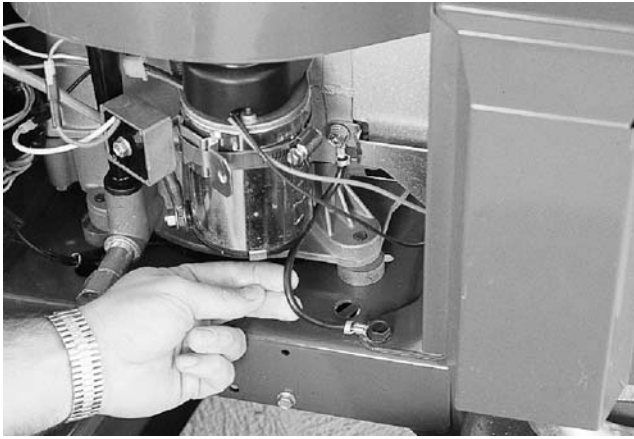


Figure 3-22.

- 10. To test for ground, connect one test lead to the positive terminal of the battery and the other lead to the engine block. If voltage is present the engine is grounded properly. If not, check that the ground wires are clean and properly connected. See Figure 3-23.

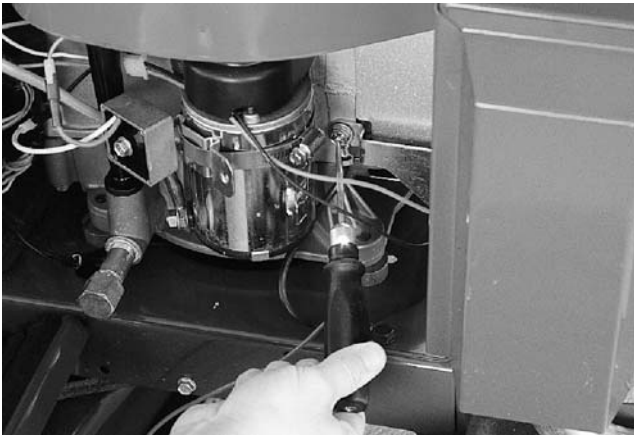


Figure 3-23.

- 11. Check for voltage at the starter motor by connecting one lead to your tester to the engine ground. Touch the other lead to the starter motor terminal. Turn the key to the start position. If voltage is present and the engine does not crank, all circuits are working properly and the problem is in the engine. Contact your authorized engine service dealer. See Figure 3-24.

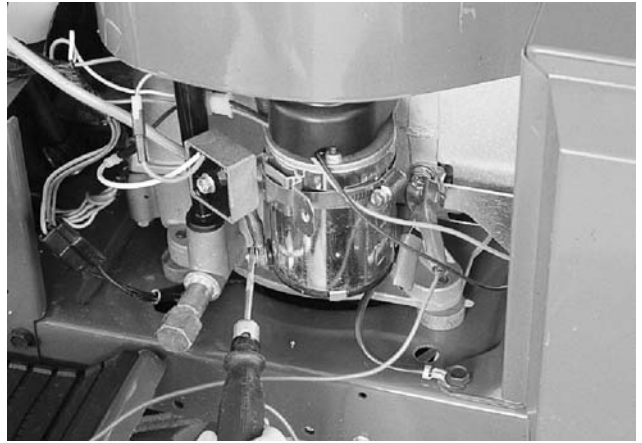


Figure 3-24.

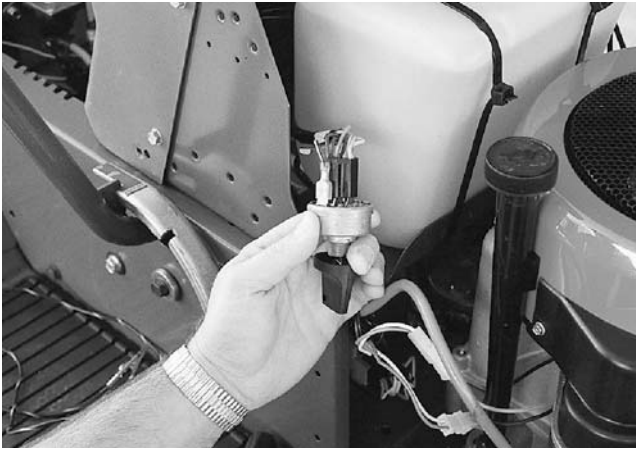
- 12. If voltage was not present at the orange wire on the solenoid while cranking the engine, you will need to check the ignition switch and safety interlock switches to see if they are being activated properly. There are three switches which must be activated in order to crank the unit: the ignition switch, the clutch/brake pedal switch, and the deck lift lever switch or PTO switch if your unit has an electric PTO.

Make certain the switch activators are depressing the plungers on the switches. Also, check for proper wire connection at the switch terminals.

**→ NOTE**

- 13. Check the ignition switch to be certain the wire harness connector is completely secured to the ignition switch terminals. Wires on the harness plug at the ignition switch should be installed as illustrated. If the unit still fails to start you will need to test the ignition switch further.
- 14. For clarity we have removed the ignition switch. See Figure 3-25.





**Figure 3-25.**

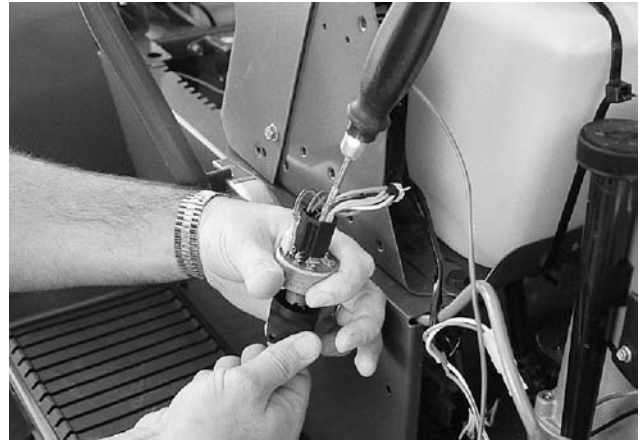
There is a seat safety switch and a reverse safety switch on this unit; however, they are not involved in the cranking circuit.

15. Using a test light or meter, connect one lead to ground. Connect the other lead to the black terminal on the ignition switch. Voltage should always be present. See Figure 3-26.



**Figure 3-26.**

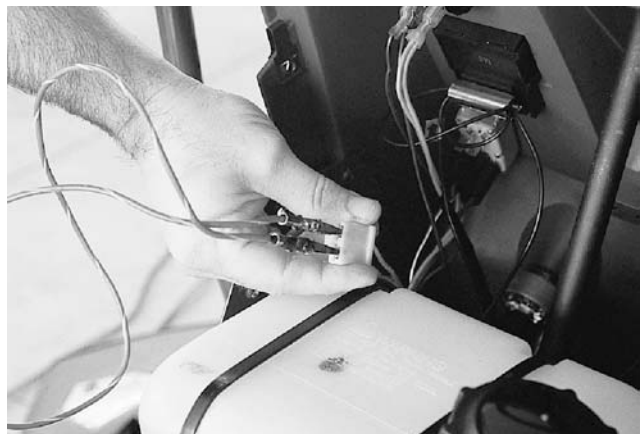
16. Move the tester from the black lead to the orange lead. Turn the ignition key to the start position. If voltage is present, the ignition switch is good. If no voltage is present, replace the ignition switch. If the unit still fails to crank, continue testing. See Figure 3-27.



**Figure 3-27.**

17. For units without an electric PTO, raise the deck lift lever fully and make sure the plunger on the safety switch is fully depressed. Attempt to start the unit. If it does not crank, remove the PTO switch. Using a jumper wire, connect between the two orange terminals. If the unit now cranks, replace the deck lift lever safety switch.

18. If you have an electric PTO, remove the connector from the PTO switch. Jump between the two orange terminals. If the unit now cranks, replace the PTO switch. See Figure 3-28.



**Figure 3-28.**

19. If the unit does not crank, make sure the clutch/brake pedal switch is fully depressed. Remove the switch and jump a wire between the two orange terminals. See Figure 3-29.

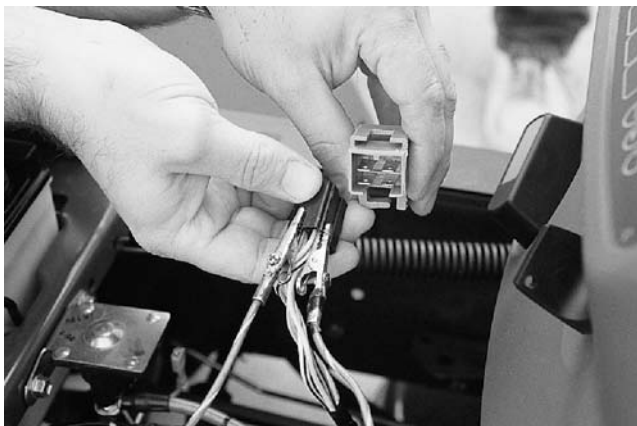


Figure 3-29.

- 20. If the unit cranks, replace the clutch brake pedal safety switch.

**Problem:** The engine cranks but will not start.

- 1. Check the fuel tank for gas.
- 2. Check to be certain the spark plug wire is firmly connected to the spark plug terminal.
- 3. Check the throttle and/or choke for proper starting position.
- 4. Disconnect the yellow ground wire on the engine. If the engine starts, the problem is with the safety switches or wiring harness.
- 5. If the engine fails to start, and you do not have an afterfire solenoid, the problem is in the engine and must be repaired by an authorized engine service dealer.
- 6. If you do have an engine with an afterfire solenoid attach your tester to the red wire and ground. Voltage should be present in the start and run positions. If voltage is not present, replace the ignition switch. See Figure 3-30.



Figure 3-30.

- 7. Disconnect the wires or harness connector from the clutch/brake safety switch.

With another wire, jump across the two red or orange wires in the harness connector and start the unit. If unit starts, the switch is defective and must be replaced.

- 8. Disconnect the yellow wires on the deck lift lever safety switch or PTO safety switch if your unit has an electric PTO. Jump across the red or orange wires. If engine starts, the switch is defective and must be replaced. See Figure 3-31.



Figure 3-31.

- 9. Check the ignition switch by removing the yellow wire from the switch harness and try to start the unit. If the unit starts, replace the ignition switch. Reinstall the yellow wire to the connector to stop the engine. See Figure 3-32.





**Figure 3-32.**

**Problem:** The engine stalls when engaging clutch/brake pedal.

Check both the reverse safety switch and seat safety switch for grounding out conditions.

**➔ NOTE**

Wires must not come into contact with the unit when checking these connections.

1. Disconnect the yellow wire on the reverse safety switch. With the engine running, place the shift lever in neutral and release the clutch/brake pedal. See Figure 3-33.



**Figure 3-33.**

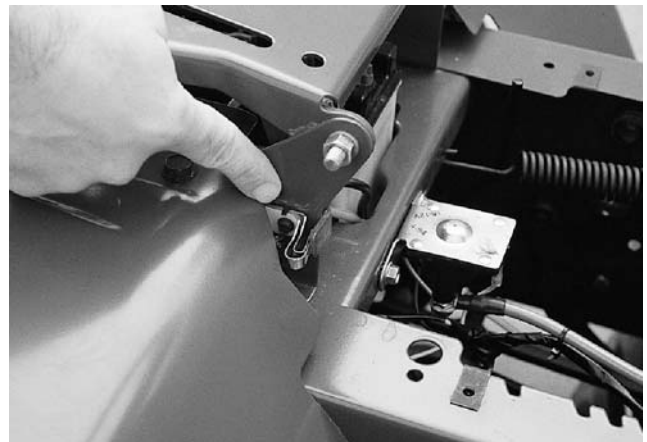
If the engine continues to run, the screws on the reverse safety switch are grounding out against the reverse safety switch bracket.

Correct by removing the screws that hold the reverse safety switch to the bracket. Inspect the insulator plate for cracks or distortion,

which can occur if the screws are improperly installed. Replace if defective.

2. If the engine stalls when testing the reverse safety switch, check the seat safety switch by disconnecting both yellow wires on the switch.

With the engine running and the shift lever in neutral, release the clutch/brake pedal. If the engine continues to run, the problem is with the insulator plate on the seat safety switch. Inspect in the same manner as the reverse safety switch. Replace if defective. See Figure 3-34.



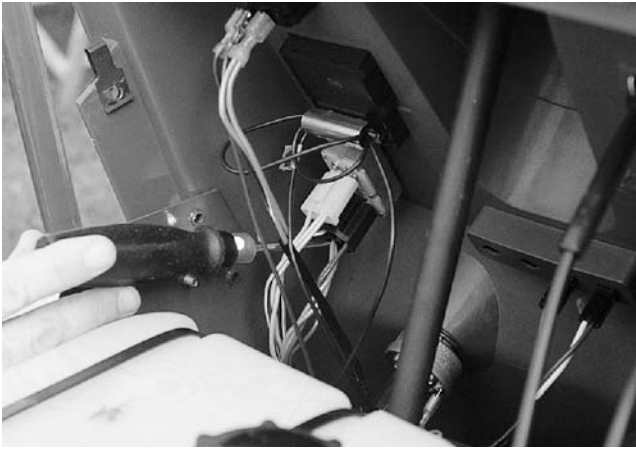
**Figure 3-34.**

**Problem:** Your unit has an electric PTO and the blades do not engage when activating the PTO switch.

1. Check for voltage at the PTO connector with the PTO switch in the on position.

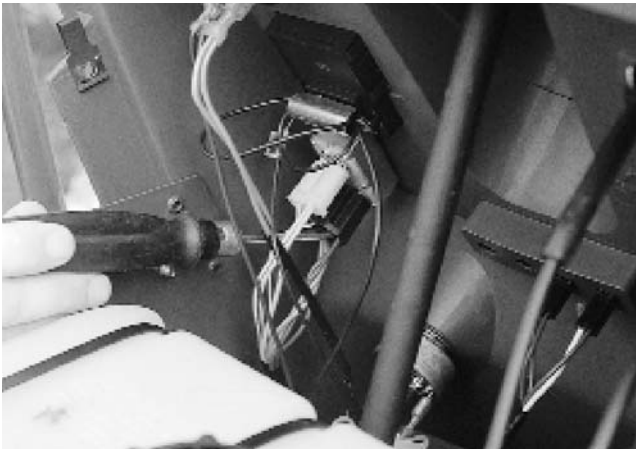
If there is voltage, adjust the PTO clutch or replace it as needed.

2. If there is no voltage, check for voltage at the red wire at the PTO switch. If no voltage, check for voltage at the ignition switch. See Figure 3-35.



**Figure 3-35.**

3. If there is voltage at the red wire at the PTO, switch the PTO to the start position and check for voltage at the blue and brown wire. If there is no voltage at either, replace the PTO switch. See Figure 3-36.



**Figure 3-36.**

**Problem:** The engine stalls when engaging blade or the blades do not engage when going into the run position on units with PTO's.

Check both the reverse safety switch and seat safety switch for grounding out conditions.

**→ NOTE**

Wires must not come into contact with the unit when checking these connections.

1. Disconnect the yellow wire on the reverse safety switch. With the engine running, engage the cutting deck.

If the blades engage without stalling the engine, the screws on the reverse safety switch are grounding out against the support

bracket or panel. Correct by removing the screws that hold the reverse safety switch to the bracket or panel. Inspect the insulator plate for cracks or distortion, which can occur if the screws are improperly installed. Replace if defective.

If the engine stalls, reconnect yellow wires and proceed to the next step.

2. Check the seat safety switch by disconnecting both yellow wires or the harness from the switch. See Figure 3-37.

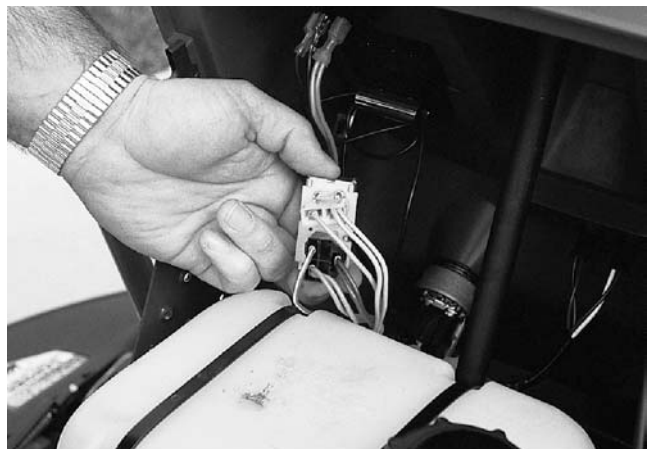


**Figure 3-37.**

With the engine running, engage the cutting deck. If the engine continues to run with the blades engaged, the problem is with the insulator plate on the seat safety switch. Inspect in the same manner as the reverse safety switch. Replace if defective.

**Problem:** PTO starts but disengages when the switch is moved to the run position.

1. Check the wiring at the PTO switch. See Figure 3-38.



**Figure 3-38.**

If correct, check voltage at PTO when blade stops turning. If voltage is present and blades are not turning, check the clutch air gap and adjust, retest, and replace the clutch if the test fails. See Figure 3-39.



**Figure 3-39.**

2. If voltage is not present, disconnect the wires from the seat safety switch and the reverse safety switch.

Operate the PTO. If it remains running, check the safety switches for shorts or broken insulator plates.

3. If the PTO doesn't operate, test the relays as follows:
  - a. Test for voltage on relay one at the white wire with the PTO switch in the start position. If there is no voltage, replace relay one. See Figure 3-40.



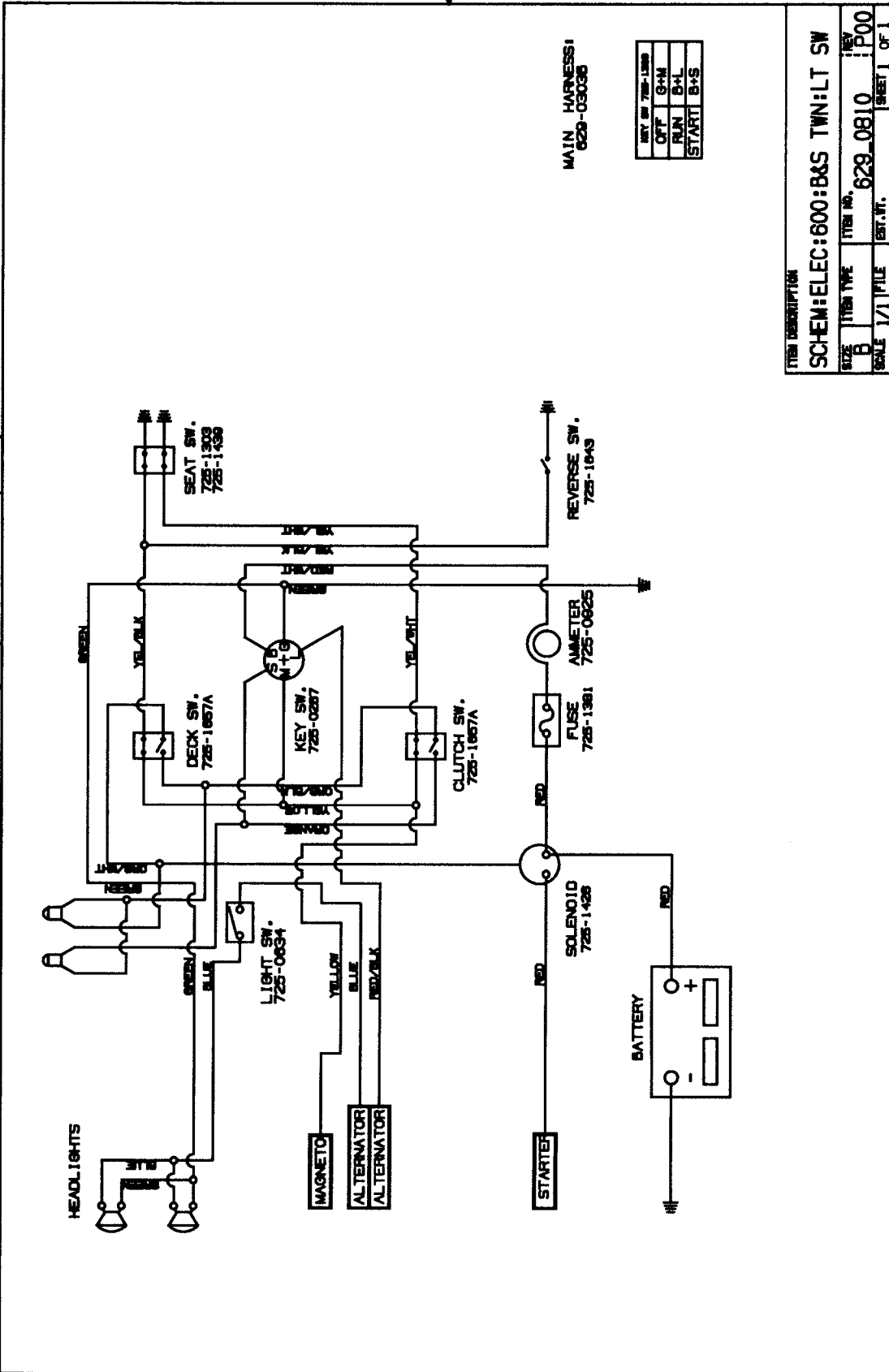
**Figure 3-40.**

- b. If voltage is present in relay one, check for voltage on the red wire of relay two.
  - c. If voltage is present, replace relay two.
4. If no voltage is present at relay two, check for voltage at the red wire on the ignition switch. If there is no voltage, replace the ignition switch. See Figure 3-41.



**Figure 3-41.**

ITEM NO. 628\_0810 REV P00



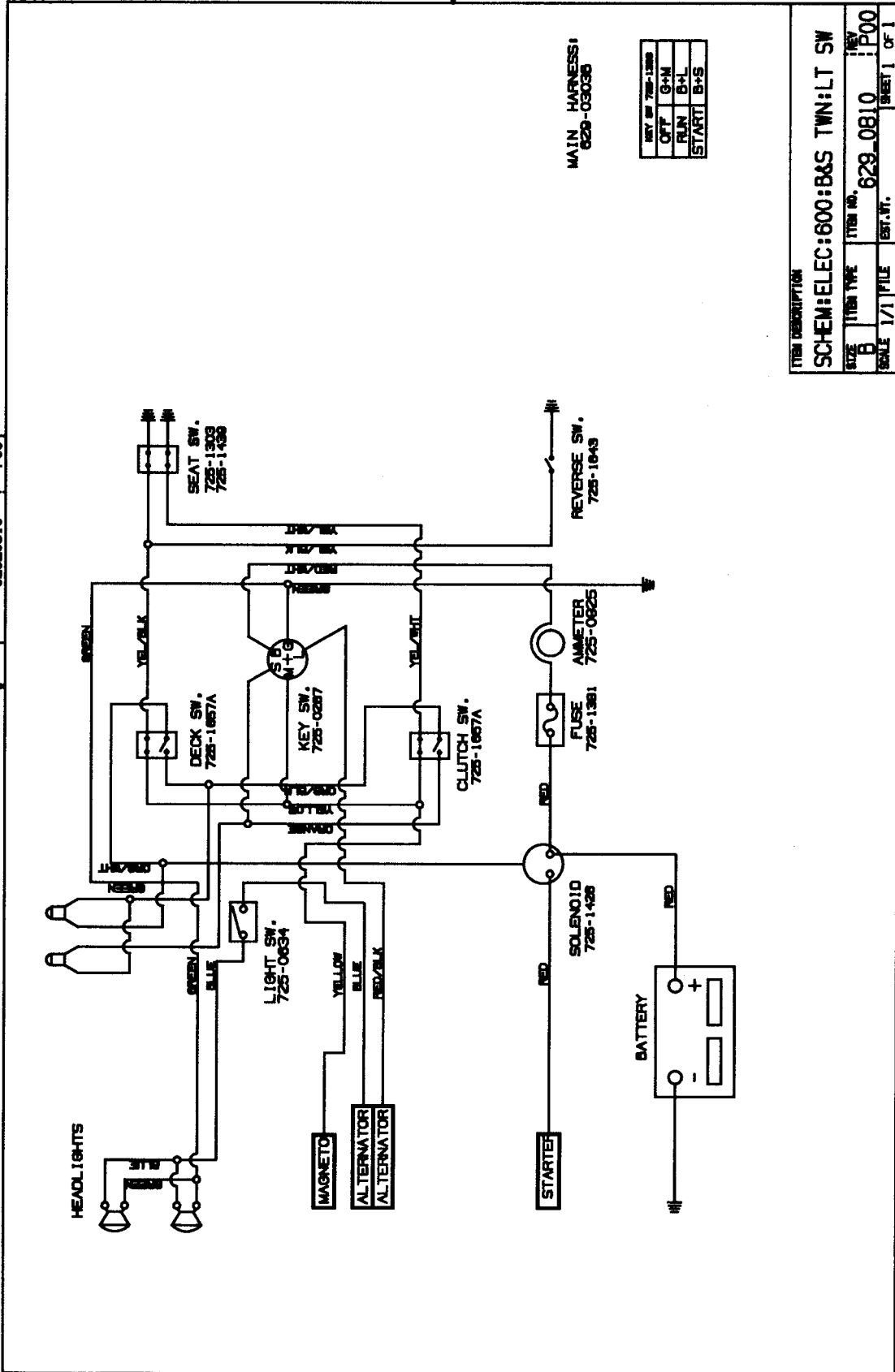
MAIN HARNESS:  
629-03038

REV SW 725-1303	OFF	G+M
	RUN	B+L
	START	B+S

ITEM DESCRIPTION  
SCHEM:ELEC:600:B&S TWIN:LT SW

SIZE	ITEM TYPE	ITEM NO.	REV
B		628_0810	P00
SCALE	1/1	FILE	SHEET 1 OF 1

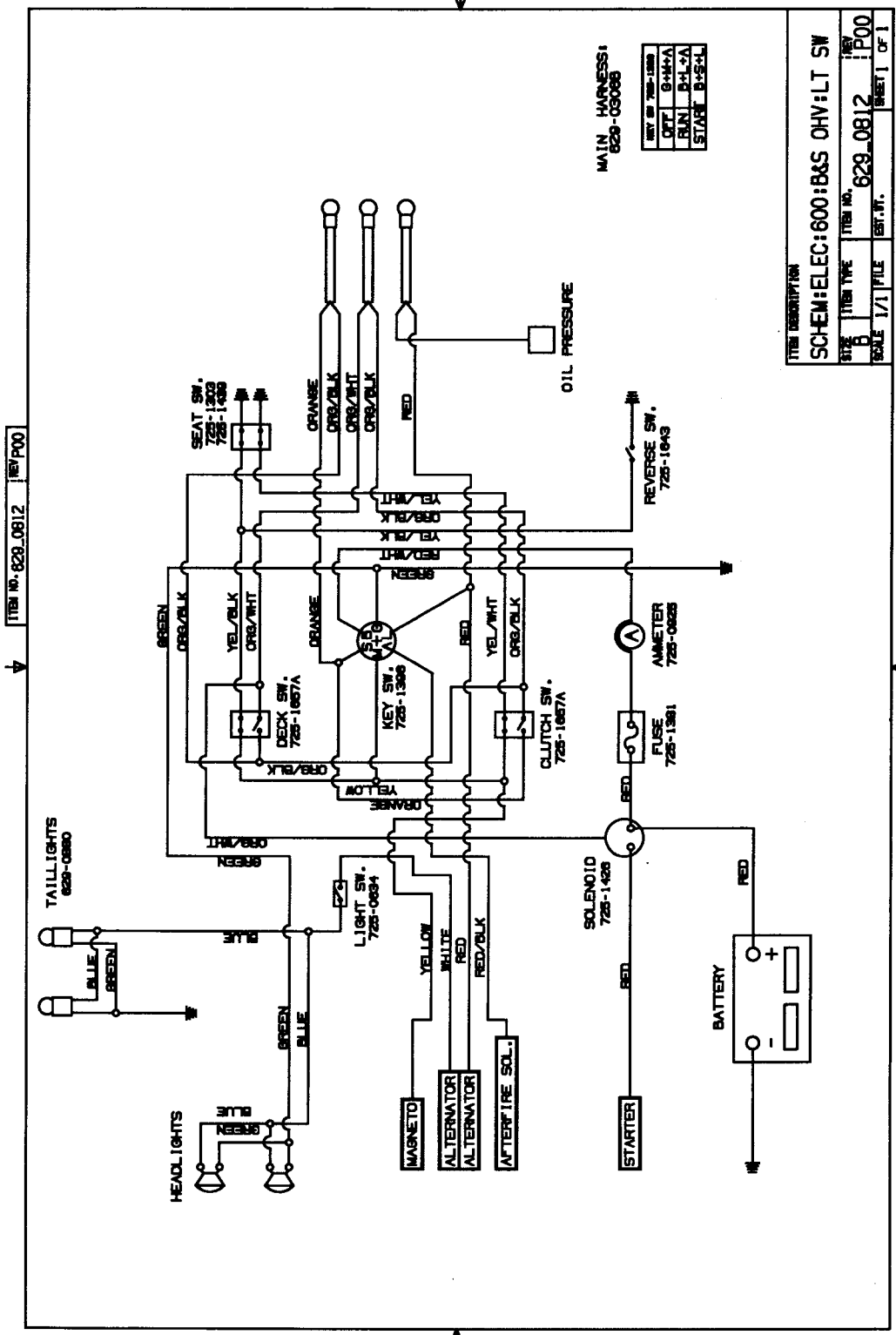
ITEM NO. 628\_0810 REV P00



MAIN HARNESS:  
628-0303B

REV. NO.	725-1388B
OFF	G+M
RUN	B+L
START	B+S

ITEM DESCRIPTION			
SCHEM:ELEC:600:B&S TWN:LT SW			
SIZE	ITEM TYPE	ITEM NO.	REV
B		628_0810	P00
SCALE	1/1	FILE	EST. WT.
			SHEET 1 OF 1

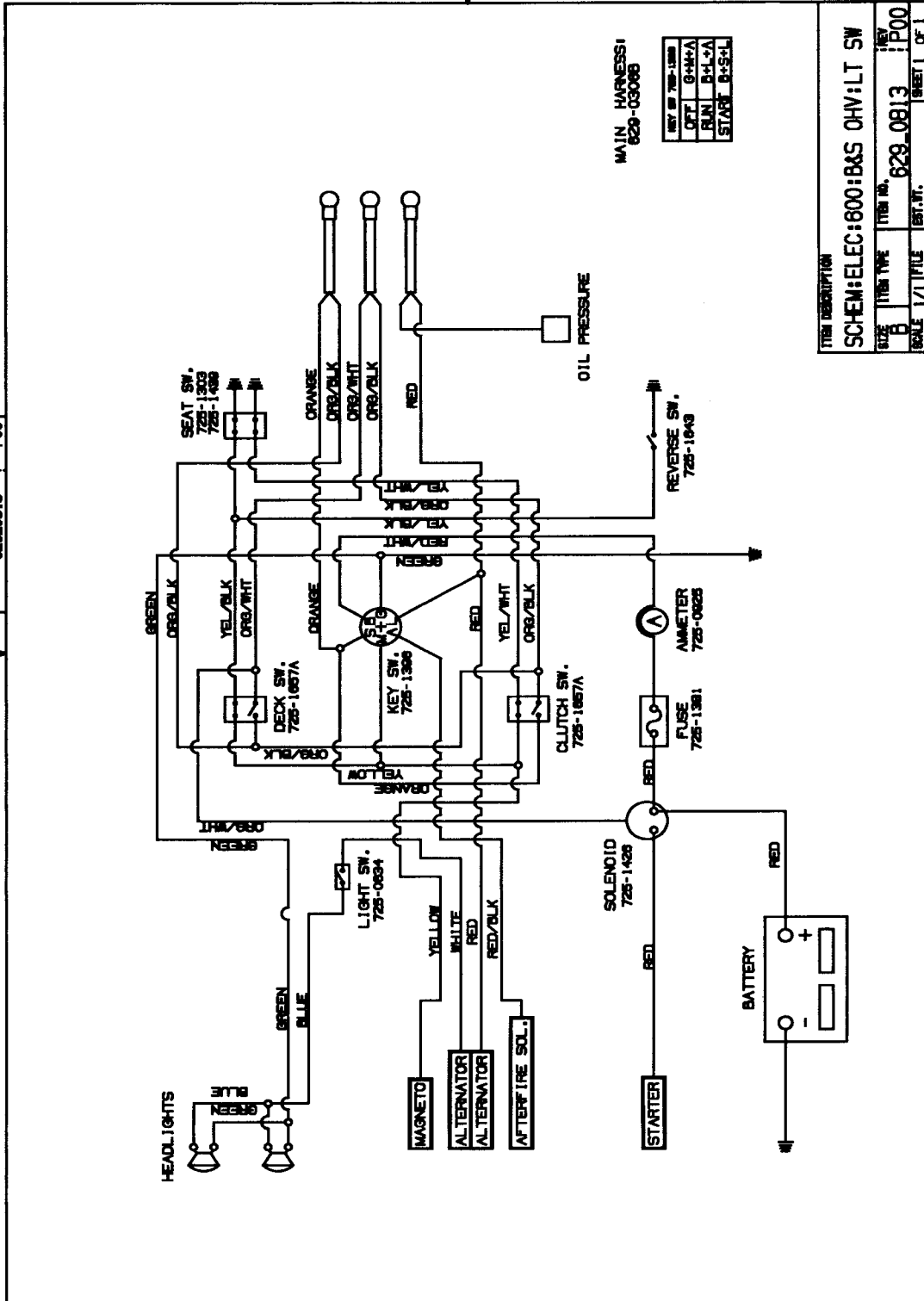


MAIN HARNESS:  
829-03098

REV. NO.	725-1288
DATE	8-14-54
BY	B.H.A.
CHKD.	B.H.A.
APPROVED	B.H.A.

ITEM DESCRIPTION			
SCHEM: ELEC: 600: B&S OHV: LT SW			
REV. NO.	725-1288	REV. NO.	829_0812
DATE	8-14-54	ITEM NO.	P00
BY	B.H.A.	SCALE	1/1
CHKD.	B.H.A.	FILE	
APPROVED	B.H.A.	EST. NO.	
			SHEET 1 OF 1

ITEM NO. 828\_0913 REV P00



MAIN HARNESS: 829-0308B

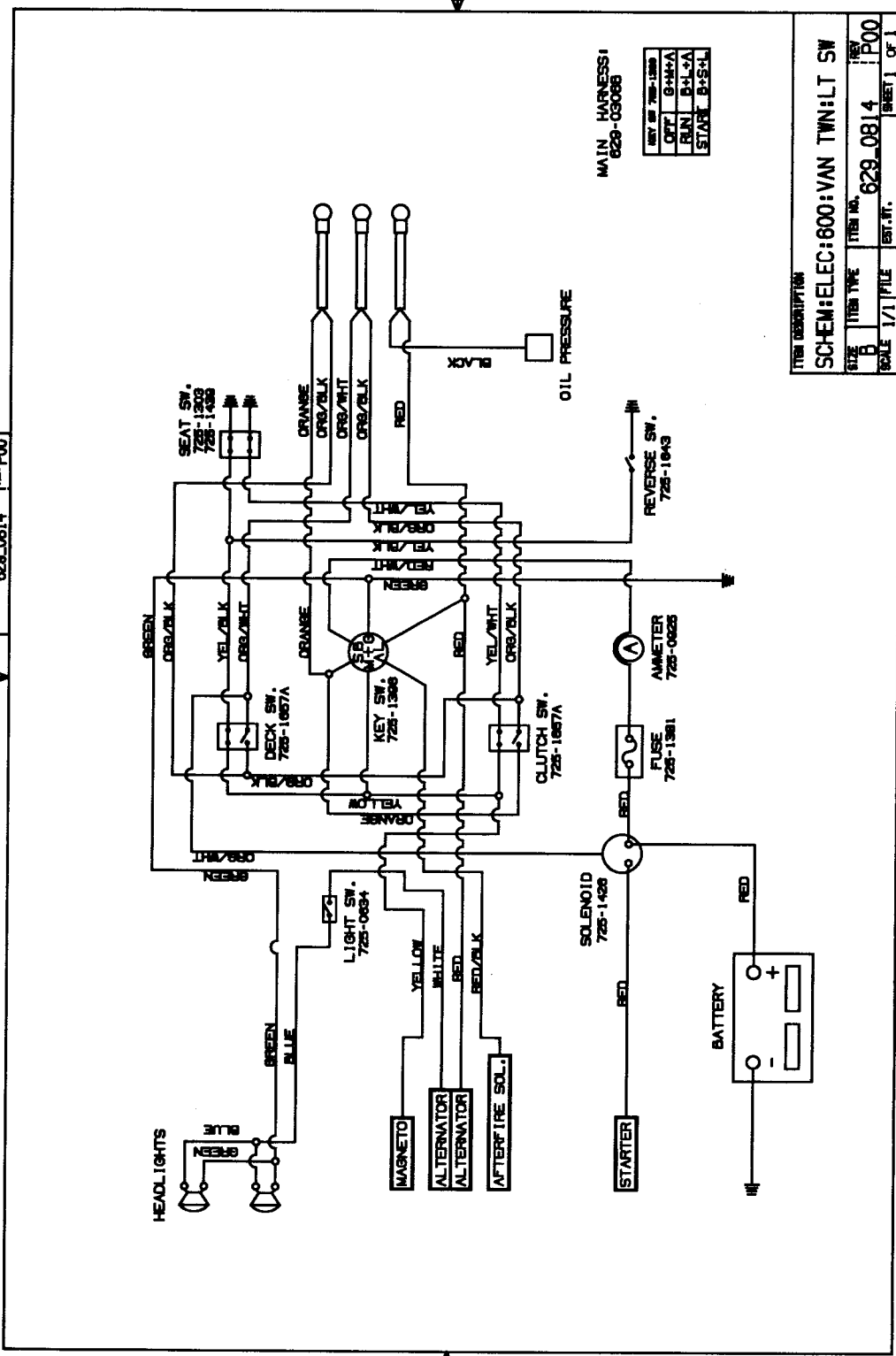
KEY SW. 725-1306	OFF	G+H+A
	RUN	B+L+A
	START	B+S+L

ITEM DESCRIPTION

SCHEM: ELEC: 600: B&S OHV: LT SW

SIZE	ITEM TYPE	ITEM NO.	REV
B		828_0913	P00
SCALE	1/1	FILE	EST. WT.
			SHEET 1 OF 1

ITEM NO. 628\_0814 REV P00



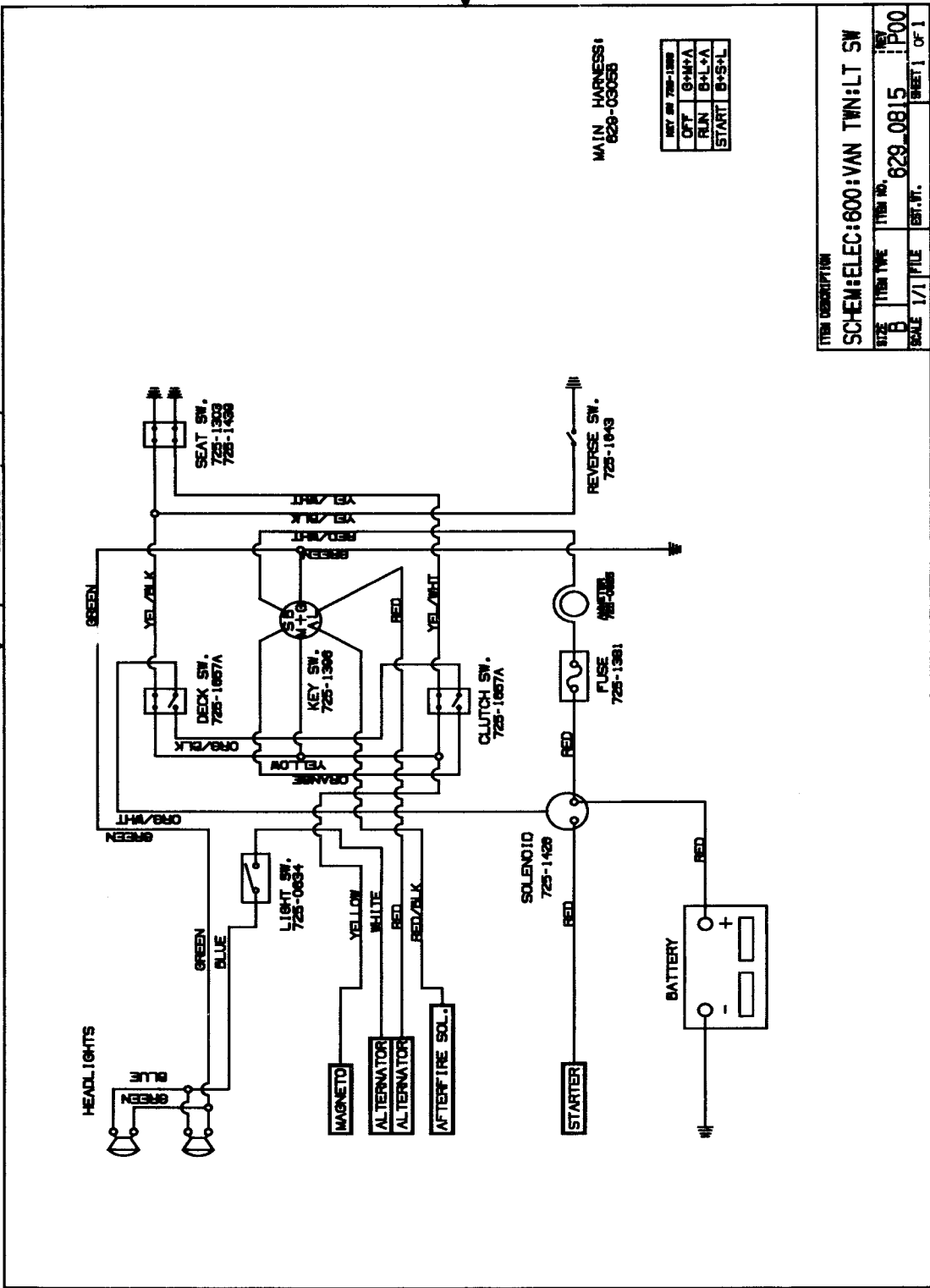
MAIN HARNESS:  
628-03088

REV. NO.	725-1366
QTY.	8-447A
RUN	B4-7A
START	B4-SH

ITEM DESCRIPTION			
SCHEM:ELEC:600:VAN TWIN:LT SW			
SIZE	ITEM TYPE	ITEM NO.	REV.
B		628_0814	P00
SCALE	1/1	FILE	SHEET 1 OF 1



ITEM NO. 629\_0815 REV P00

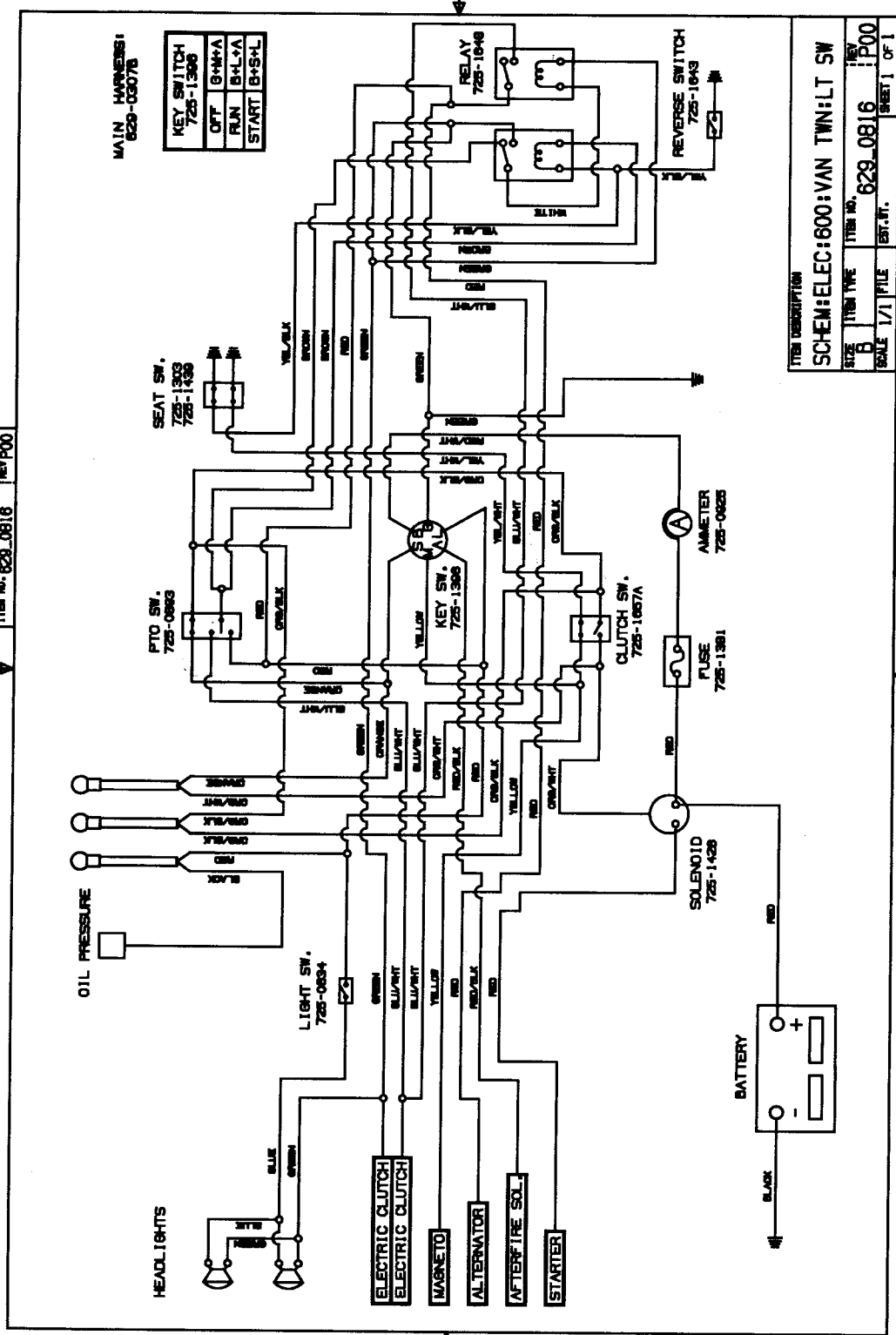


MAIN HARNESS:  
629-0305B

REV	629-1396
OFF	6+MVA
RUN	6+LVA
START	6+S+L

ITEM DESCRIPTION			
SCHEM: ELEC: 600: VAN TWIN: LT SW			
SIZE	ITEM TYPE	ITEM NO.	REV
B		629_0815	P00
SCALE	1/1	FILE	REV. NO.
			SHEET 1 OF 1

ITEM NO. 629\_0816 REV P00

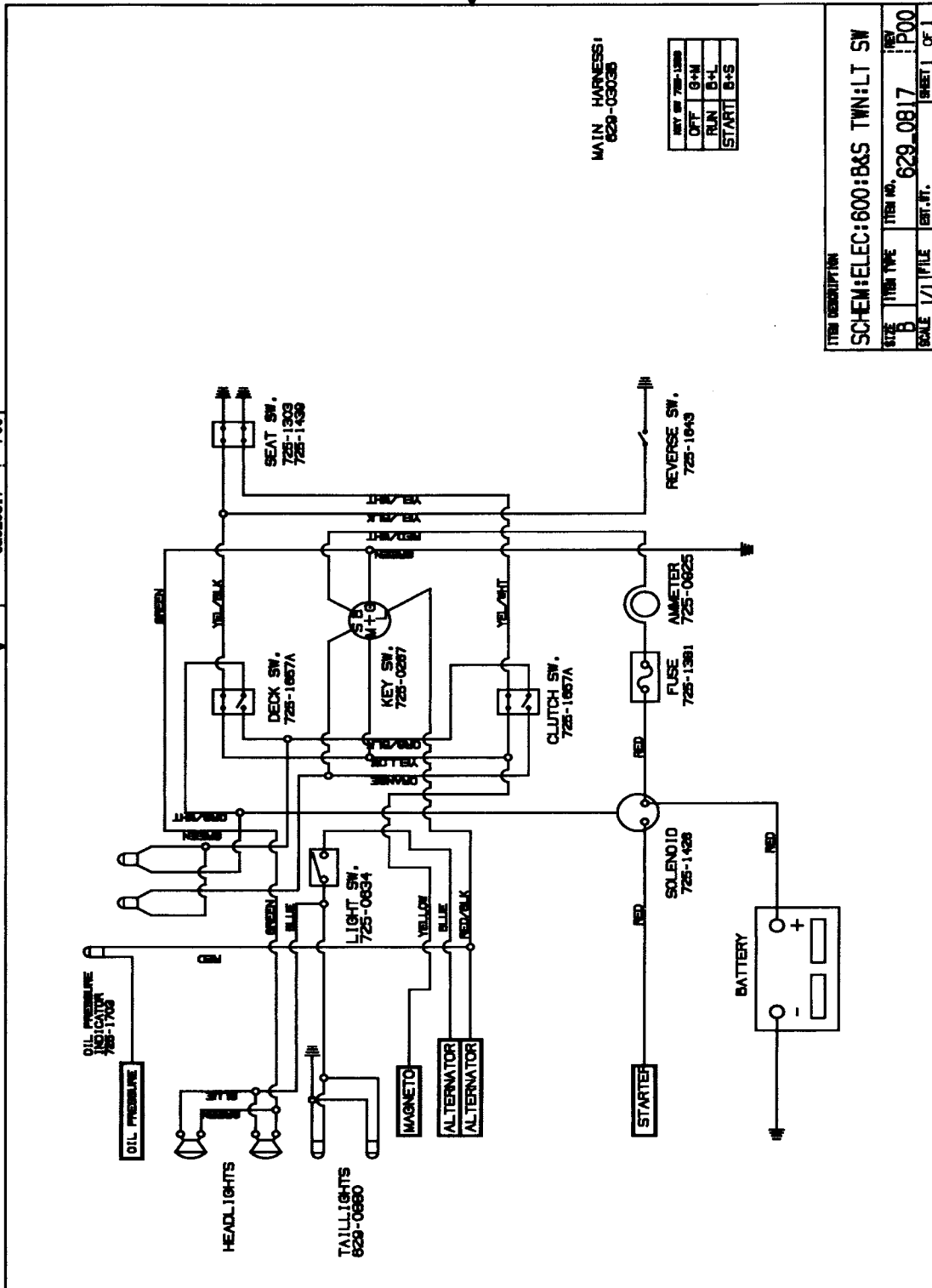


MAIN WIRING: 629-03076

KEY SWITCH 725-1396	
OFF	B+M+A
FLN	B+L+A
START	B+S+L

ITEM DESCRIPTION  
 SCHEM:ELEC:600:VAN TWN:LT SW  
 SIZE B ITEM NO. 629\_0816 REV P00  
 SCALE 1/1 FILE INT. NO. SHEET 1 OF 1

ITEM NO. 629\_0817 REV P00

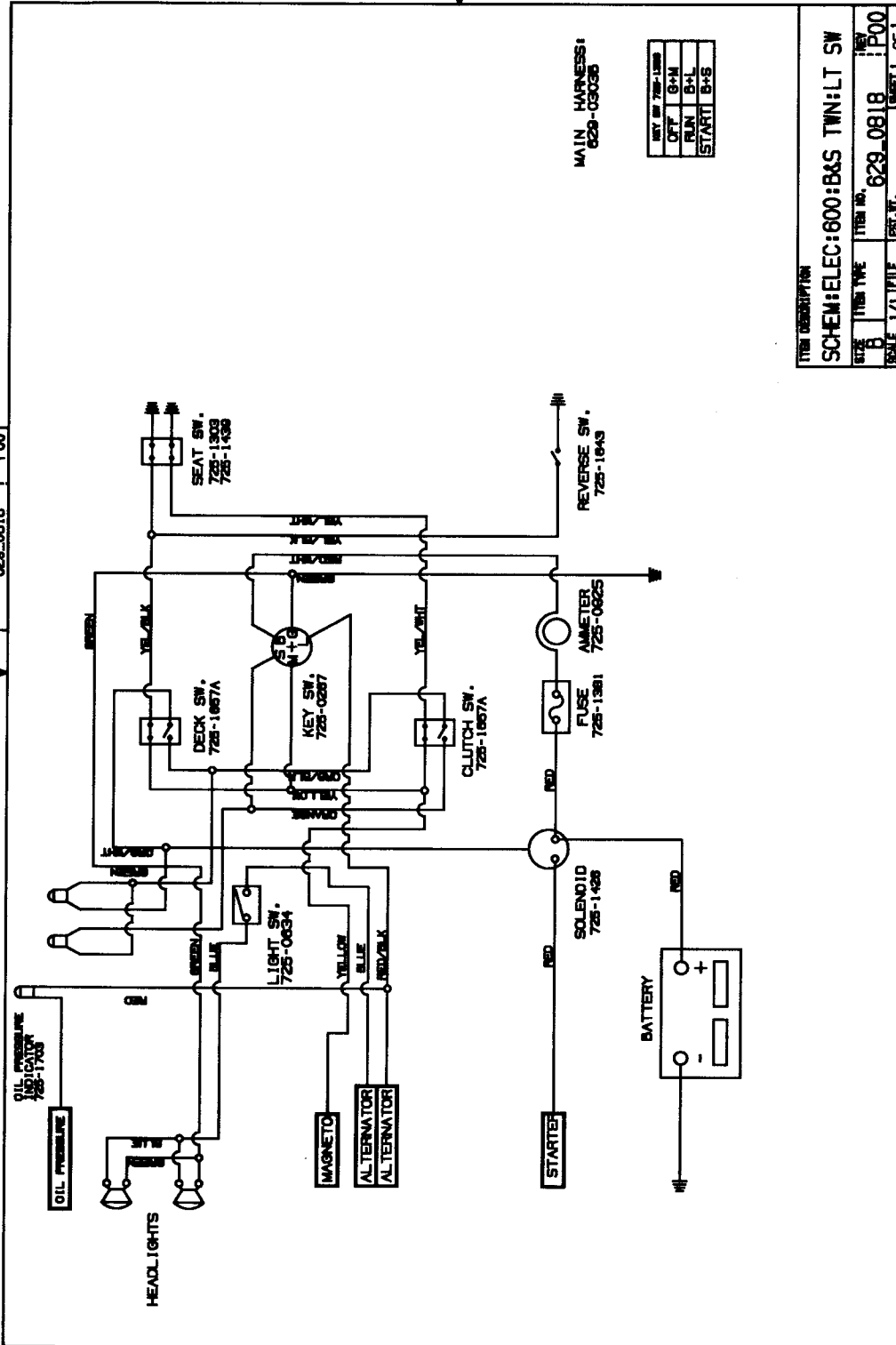


MAIN HARNESS:  
629-0303B

REV SW 725-1303
OFF G+H
RUN B+H
START B+S

ITEM DESCRIPTION			
SCHEM:ELEC:600:B&S TWIN:LT SW			
SIZE	ITEM TYPE	ITEM NO.	REV
B		629_0817	P00
SCALE	1/1	FILE	EST. DT.
			SHEET 1 OF 1

ITEM NO. 629-0818 REV P00

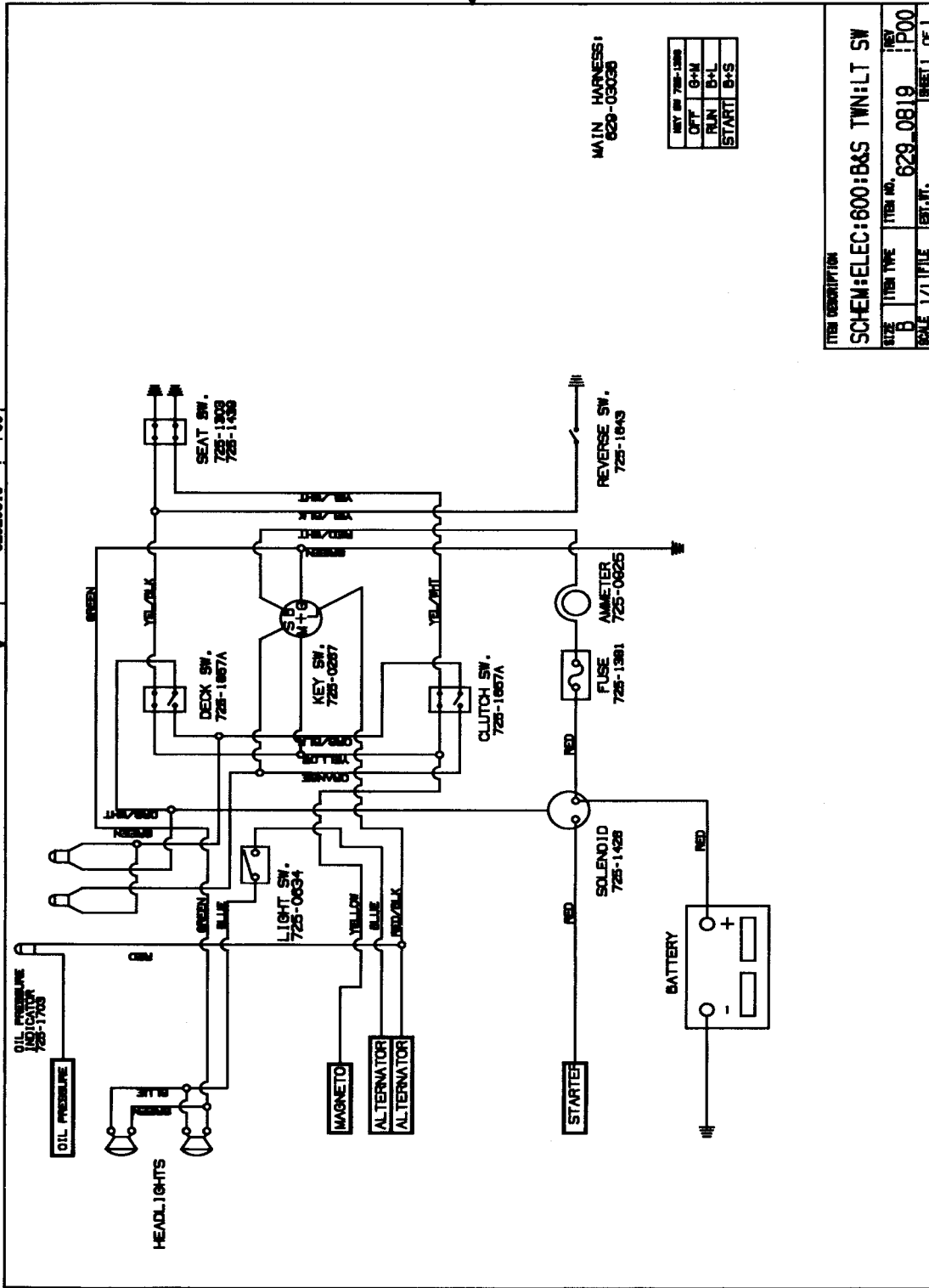


MAIN HARNESS:  
829-03038

REV SW	725-1388
OFF	G+M
RUN	B+L
START	B+S

ITEM DESCRIPTION	
SCHEM:ELEC:600:B&S TWIN:LT SW	
SIZE	ITEM NO.
B	629-0818
SCALE	SHEET
1/1	1 of 1

ITEM NO. 629\_0819 REV P00



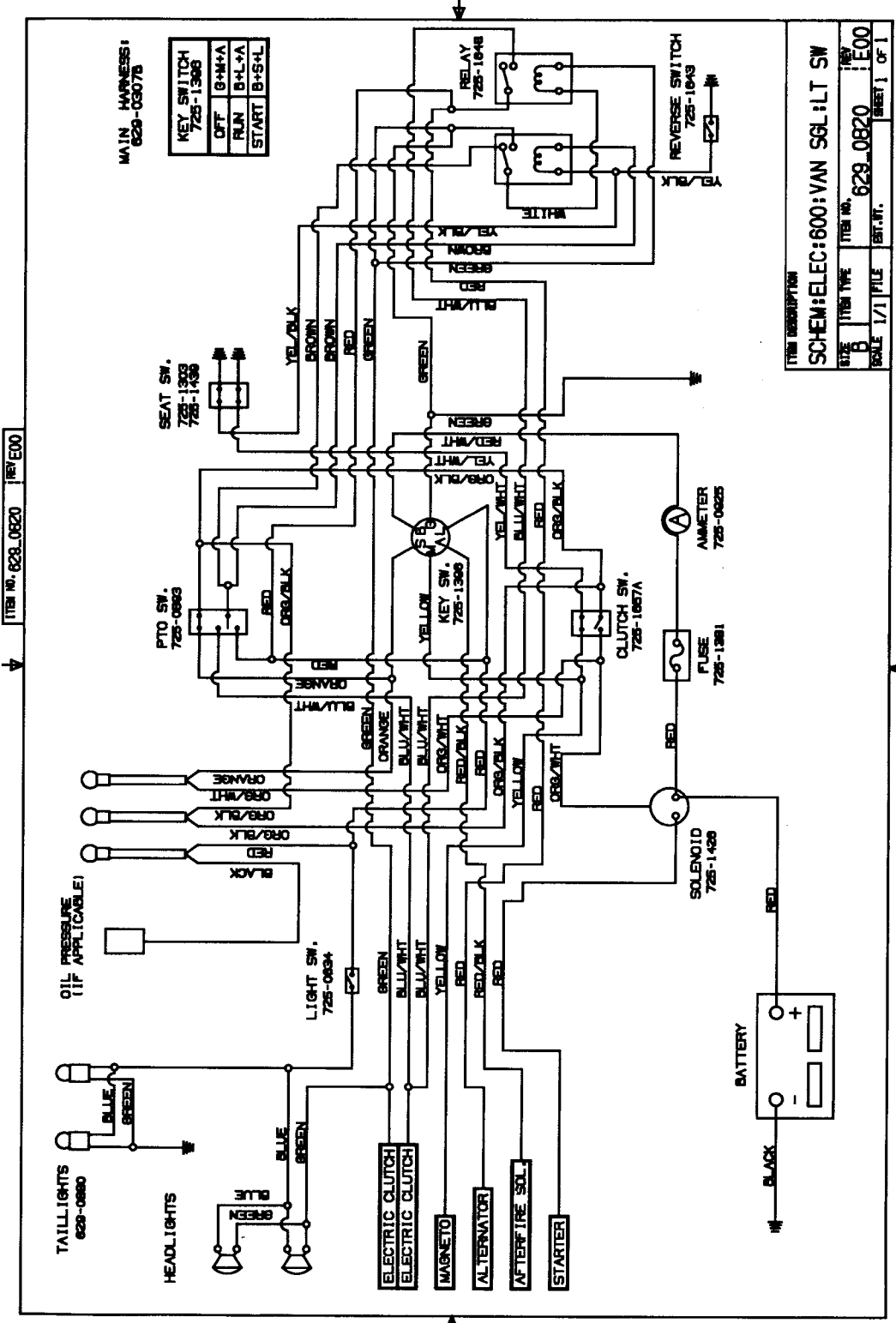
MAIN HARNESS:  
629-03038

REV SW	725-1303
CLUT SW	725-1667A
KEY SW	725-0667
DECK SW	725-1667A
SEAT SW	725-1303

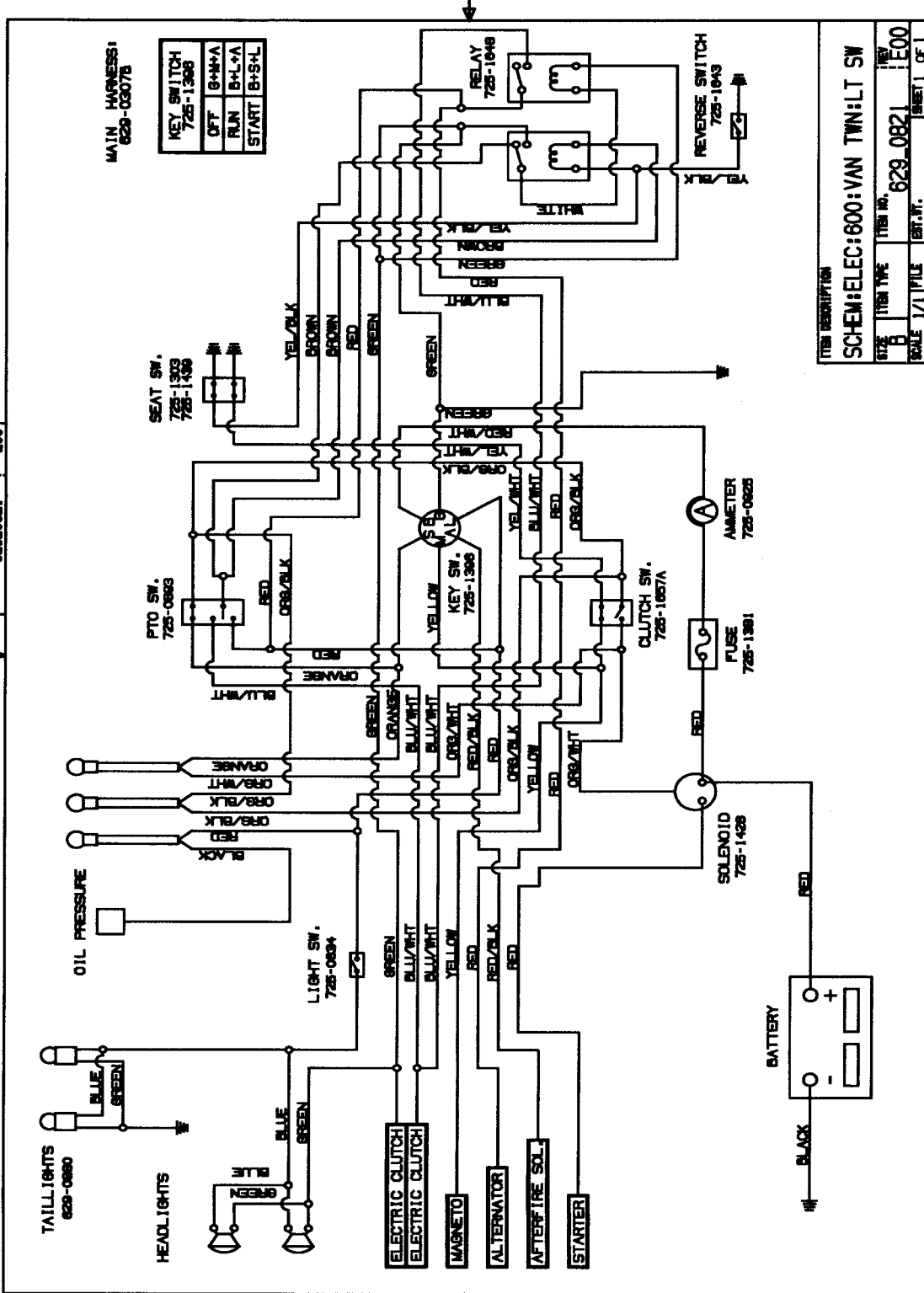
ITEM DESCRIPTION

SCHEM: ELEC: 600: B&S TWIN LT SW

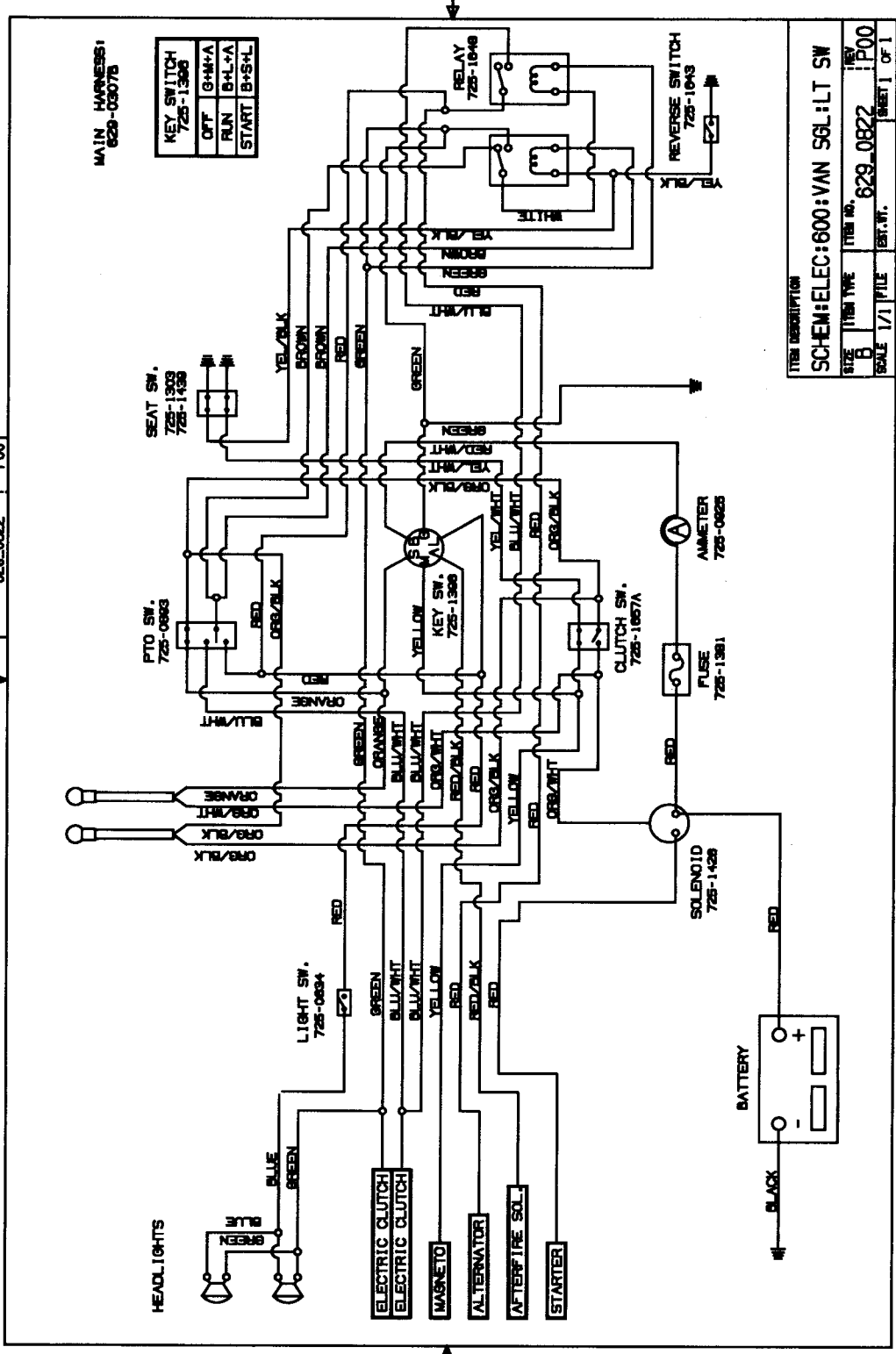
REV	REV
ITEM NO.	629_0819
ITEM TYPE	P00
SCALE	1/1 FILE
EXT. WT.	SHEET 1 OF 1



ITEM NO. 629\_082 | REV E00



ITEM NO. 628-0822 REV P00

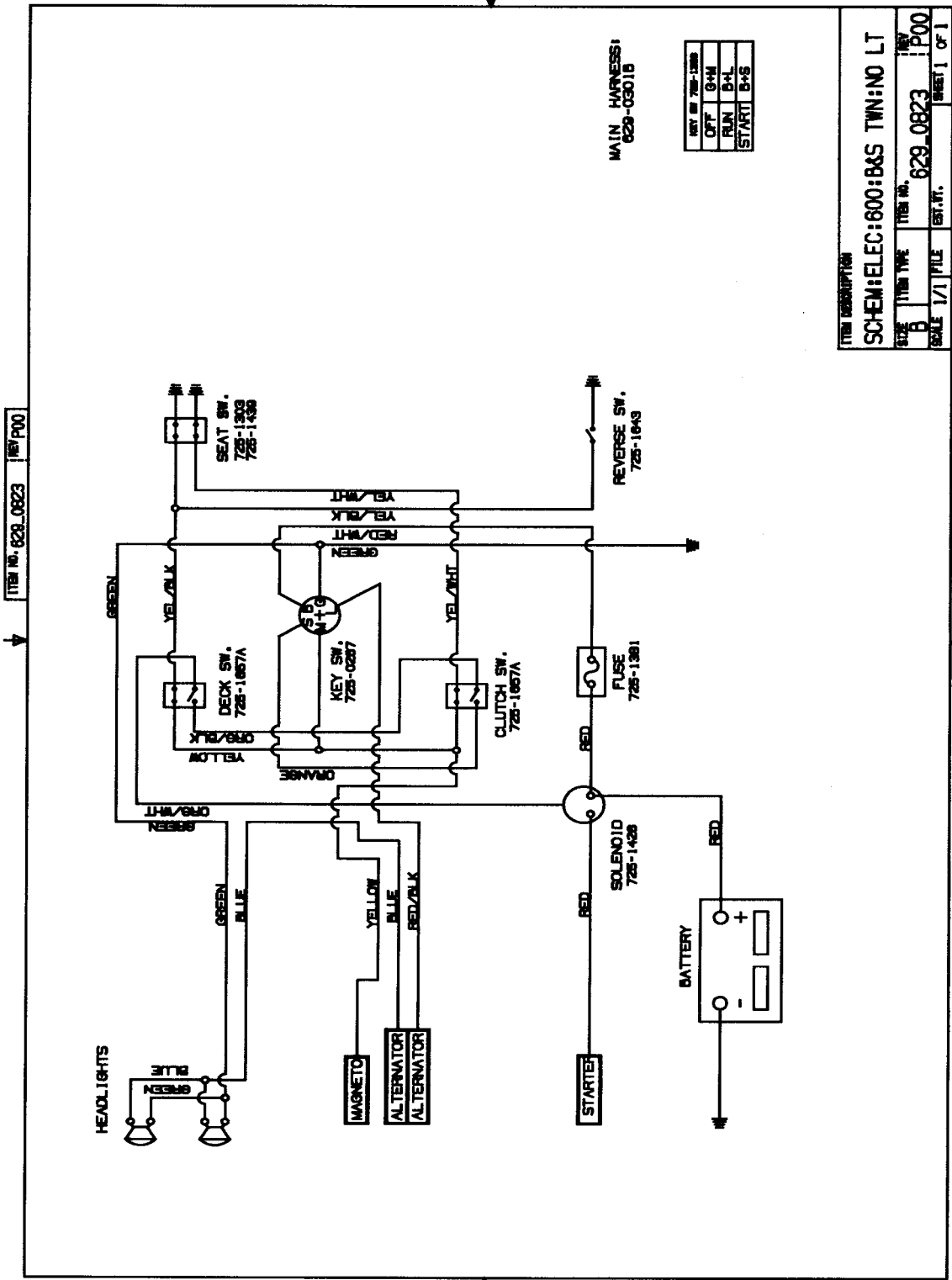


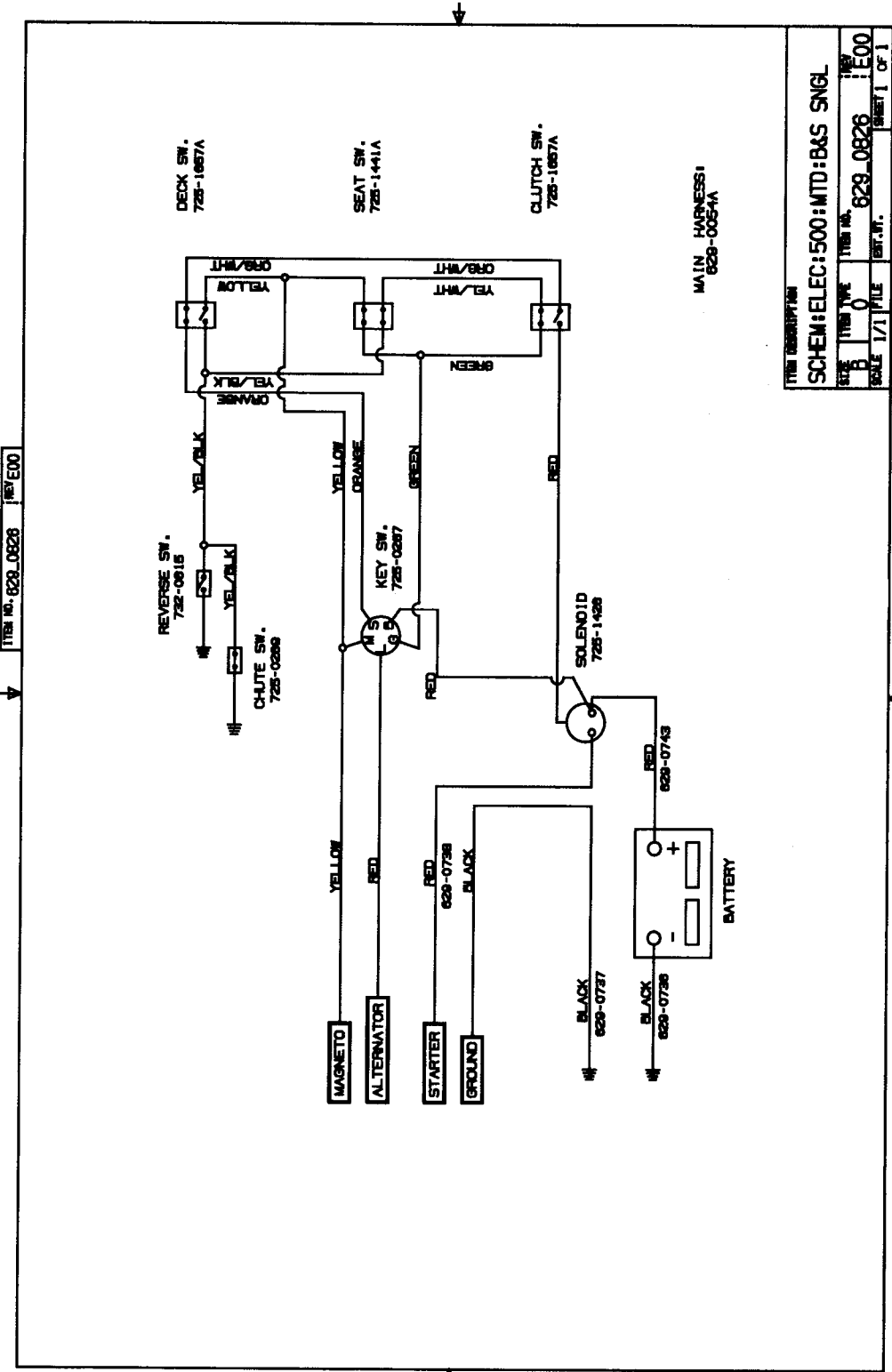
MAIN HARNESS:  
628-0307B

KEY SWITCH 725-1308	
OFF	G+H+A
RUN	B+L+A
START	B+S+L

ITEM DESCRIPTION SCHEM: ELEC: 600: VAN SGL: LT SW			
SIZE	ITEM TYPE	ITEM NO.	REV
B		628-0822	P00
SCALE	1/1	FILE	ENT. INT.
		SHEET 1 OF 1	



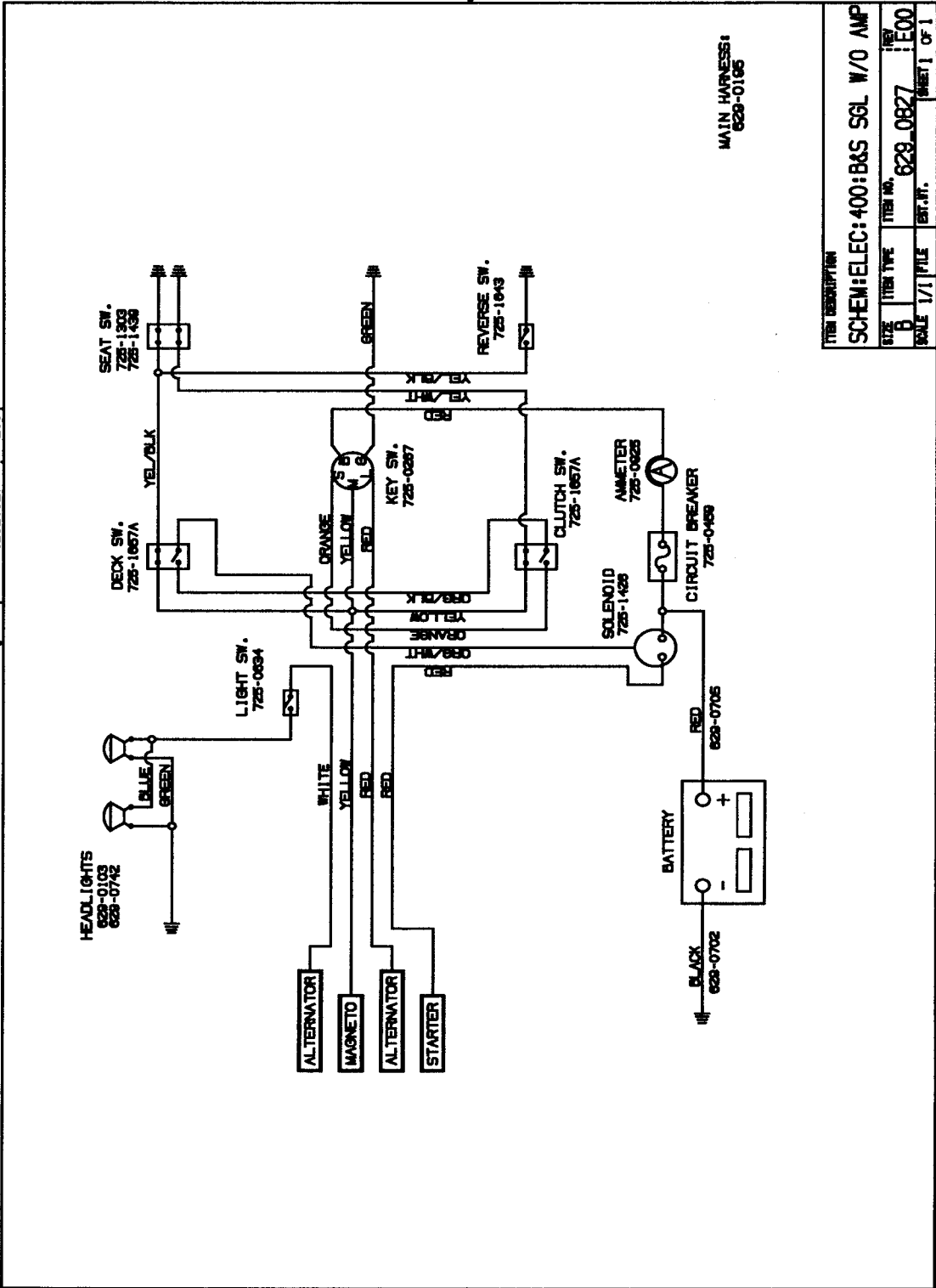




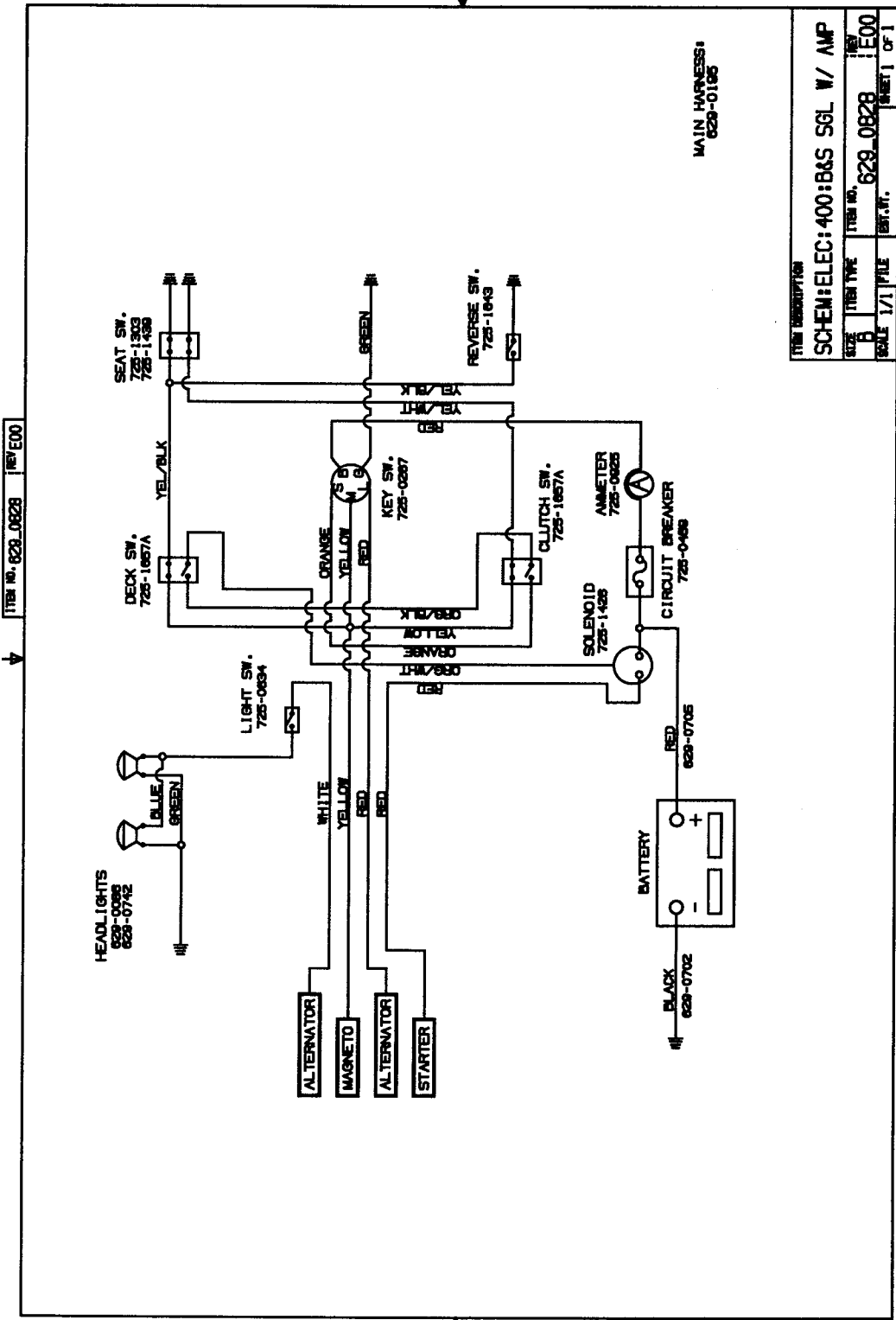
ITEM NO. 828\_0826 REV E00

ITEM DESCRIPTION			
SCHEM: ELEC: 500: MTD: B&S SINGL			
REV	ITEM NO.	ITEM NO.	REV
0	828_0826	828_0826	E00
SCALE	1/1	FILE	SHEET 1 OF 1

ITEM NO. 628\_0827 REV E00



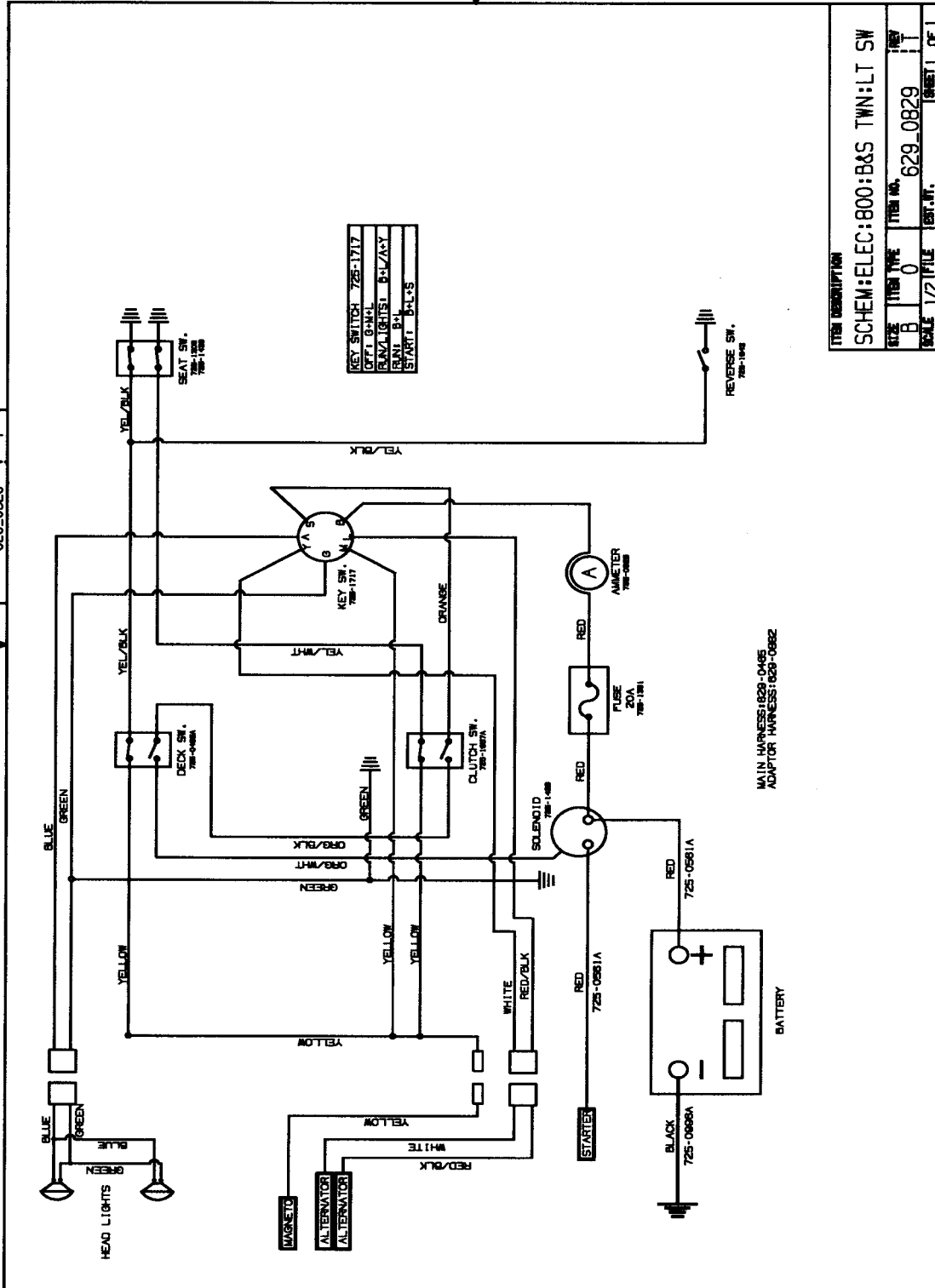
ITEM DESCRIPTION			
SCHEM: ELEC: 400: B&S SGL W/O AMP			
SIZE	ITEM TYPE	ITEM NO.	REV
B		628_0827	E00
SHEET 1/1	FILE	EXT. NO.	SHEET 1 OF 1



MAIN HARNESS:  
629-0195

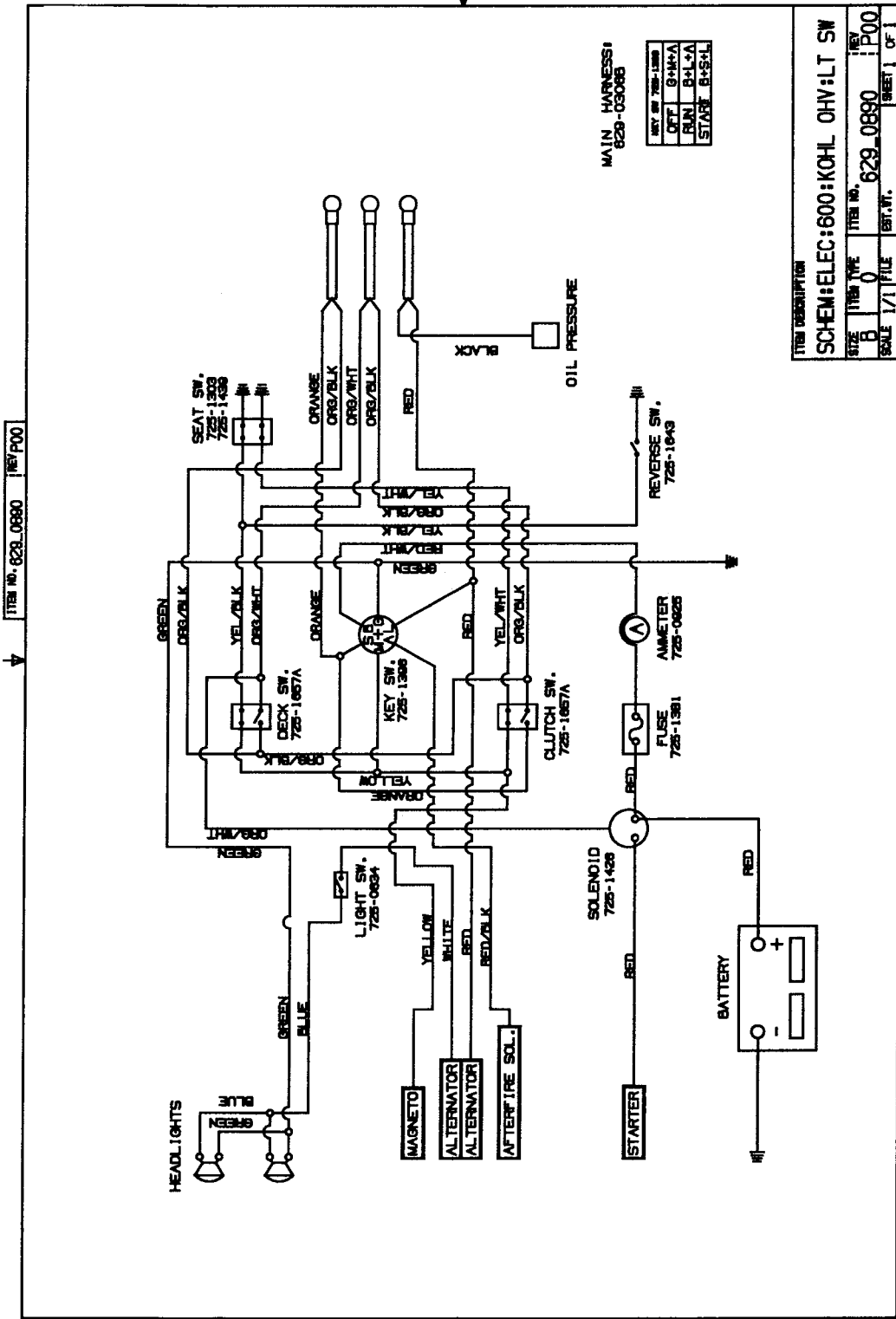
ITEM DESCRIPTION			
SIZE	ITEM TYPE	ITEM NO.	REV
B		629-0828	E00
SCALE 1/1		DATE	SHEET 1 OF 1

ITEM NO. 629-0829 REV T

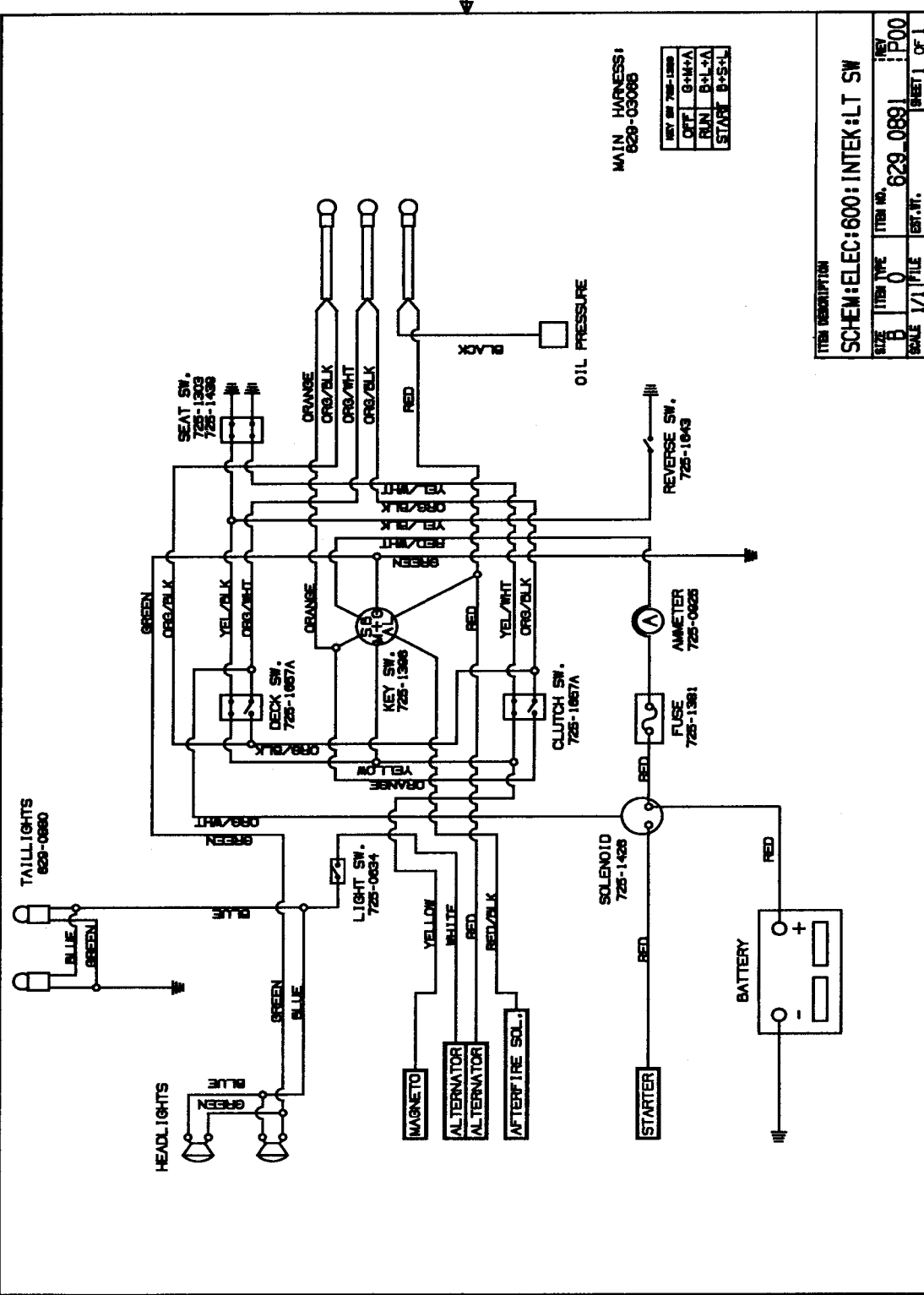


ITEM DESCRIPTION			
SCHEM: ELEC: 800: BAS TWIN: LT SW			
REV	ITEM NO.	REV	REV
B	0	629-0829	1
SCALE	1/2" FILE	ENT. WT.	SHEET 1 OF 1

MAIN HARNESS: 629-0486  
ADAPTOR HARNESS: 629-0882



ITEM NO. 629\_0891 REV P00

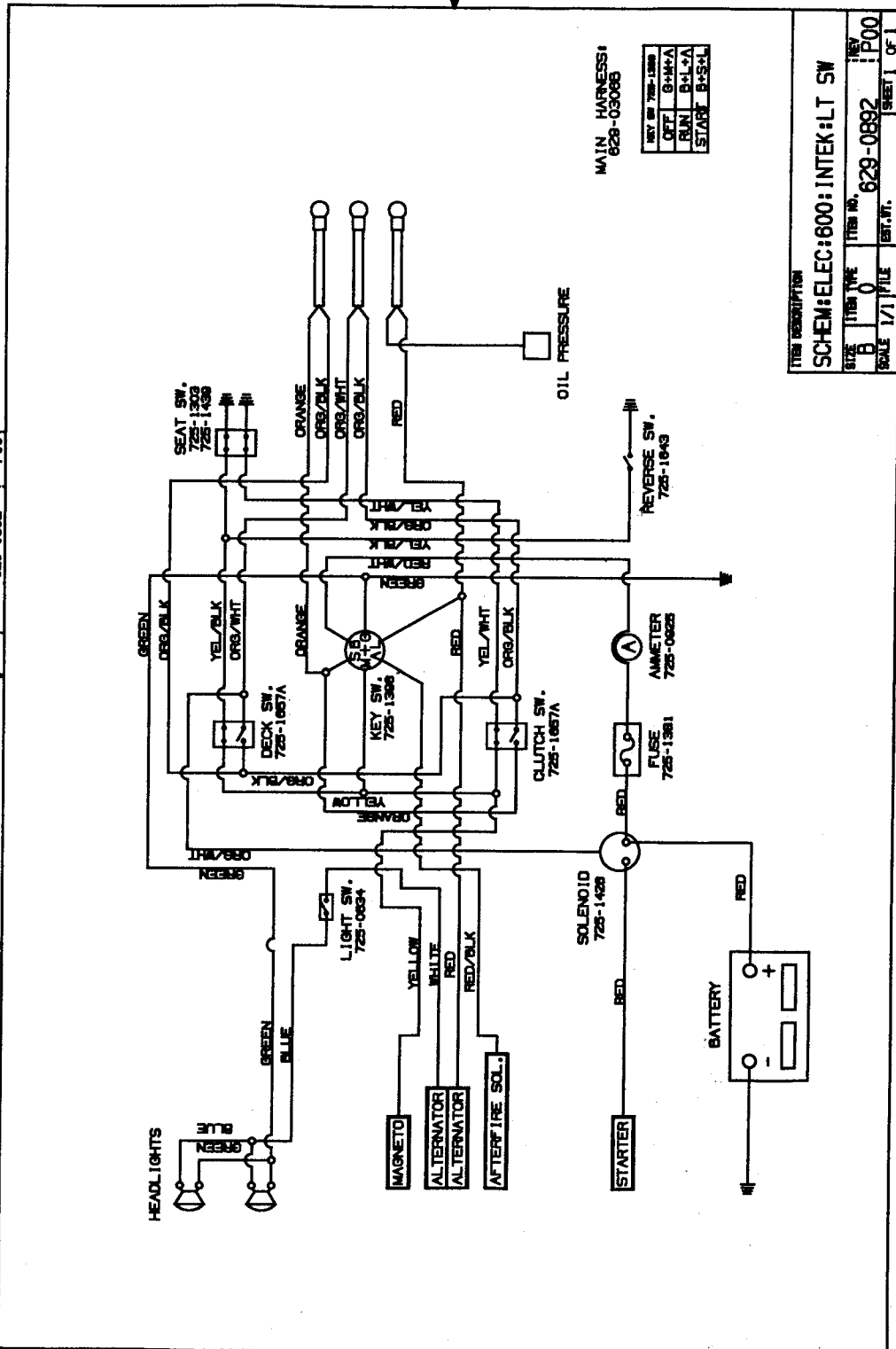


MAIN HARNESS:  
629-03066

REV	NO.	DATE
001	G+M+A	
002	B+L+A	
003	B+S+L	

ITEM DESCRIPTION			
SCHEM: ELEC: 600: INTEL: LT SW			
SIZE	ITEM NO.	REV	
B	629_0891	P00	
SCALE	1/1	FILE	SHEET 1 OF 1

ITEM NO. 629-0892 REV P00



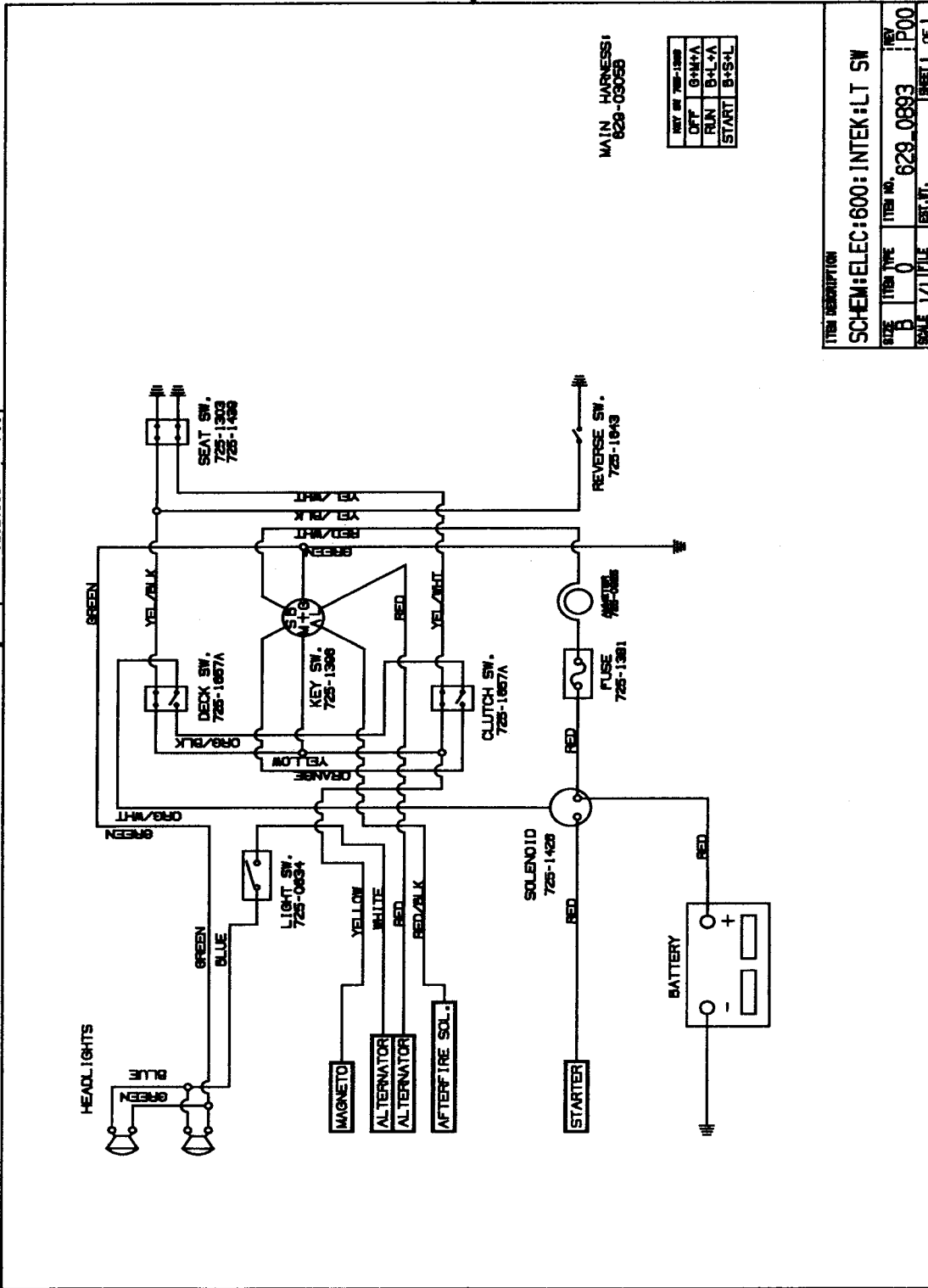
MAIN HARNESS:  
629-03068

REV. NO.	725-1388
OFF.	8-14-74
RUN.	8-14-74
START.	8-25-74

ITEM DESCRIPTION			
SCHEM: ELEC: 600: INTEK: LT SW			
SIZE	ITEM NO.	ITEM NO.	REV.
B	0	629-0892	P00
SCALE	1/1	FILE	EST. WT.
			SHEET 1 OF 1



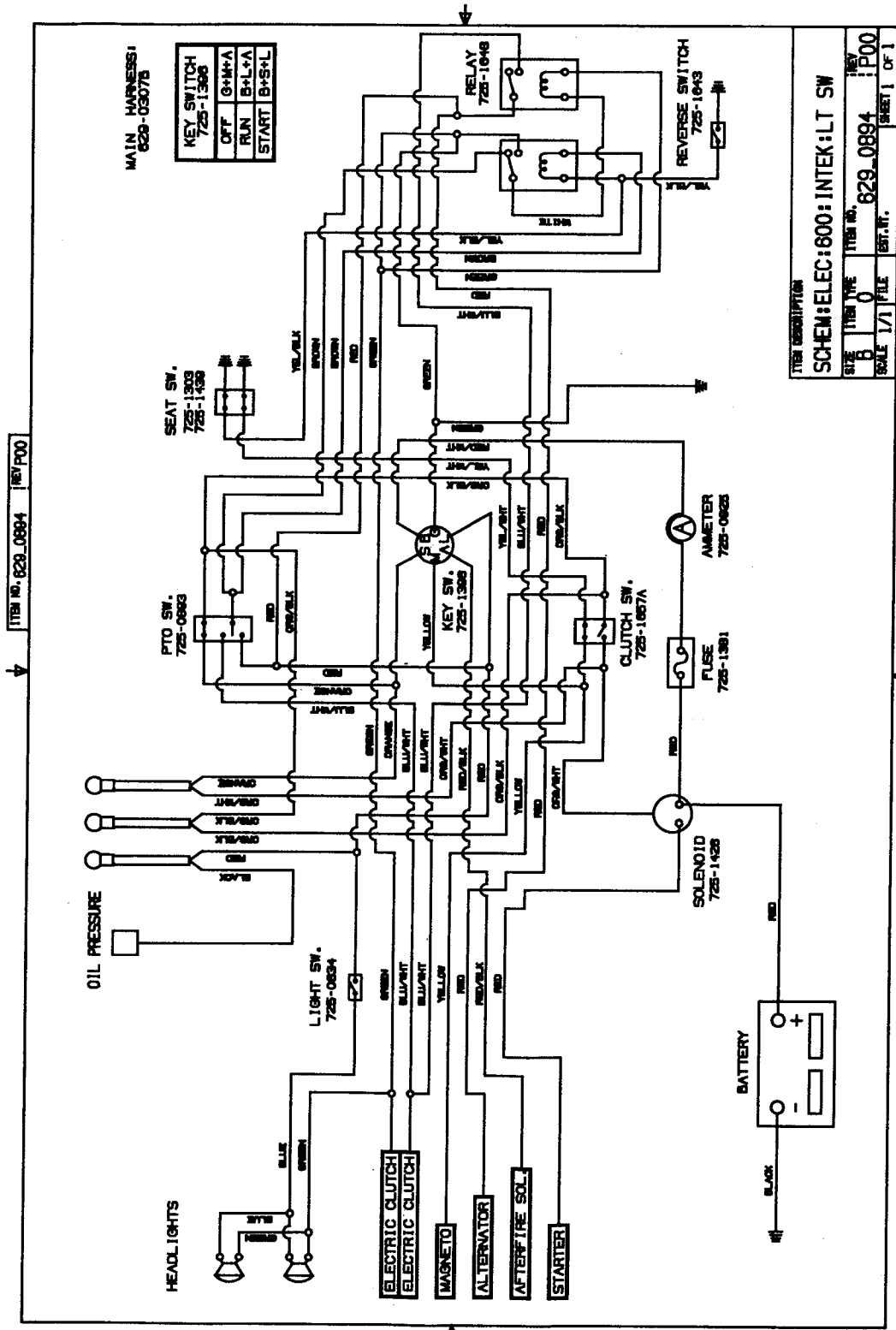
ITEM NO. 629\_0893 REV P00



MAIN HARNESS:  
629-0805B

REV	725-1368
OFF	G+M+A
RUN	B+L+A
START	B+S+L

ITEM DESCRIPTION			
SCHEM: ELEC: 600: INTEL: LT SW			
REV	ITEM NO.	ITEM NO.	REV
B	0	629_0893	P00
SCALE	1/1	FILE	EST. DT.
			SHEET 1 OF 1



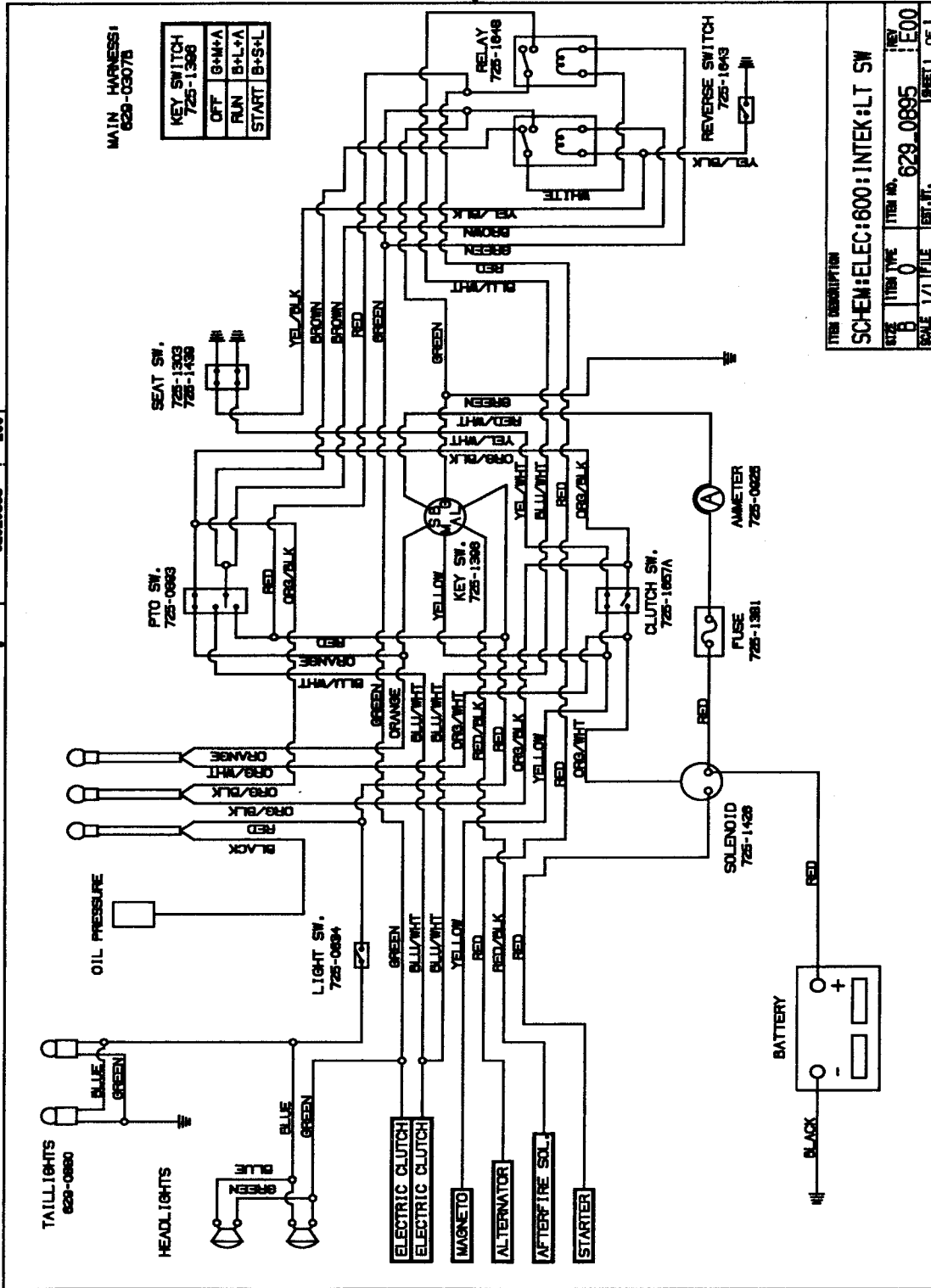
ITEM DESCRIPTION  
**SCHEM:ELEC:800:INTEK:LT SW**

SIZE	ITEM TYPE	ITEM NO.	REV
B	0	629-0894	P00
SCALE	1/1	FILE	SST.N.T.

SHEET 1 OF 1

ITEM NO. 629-0894 REV P00

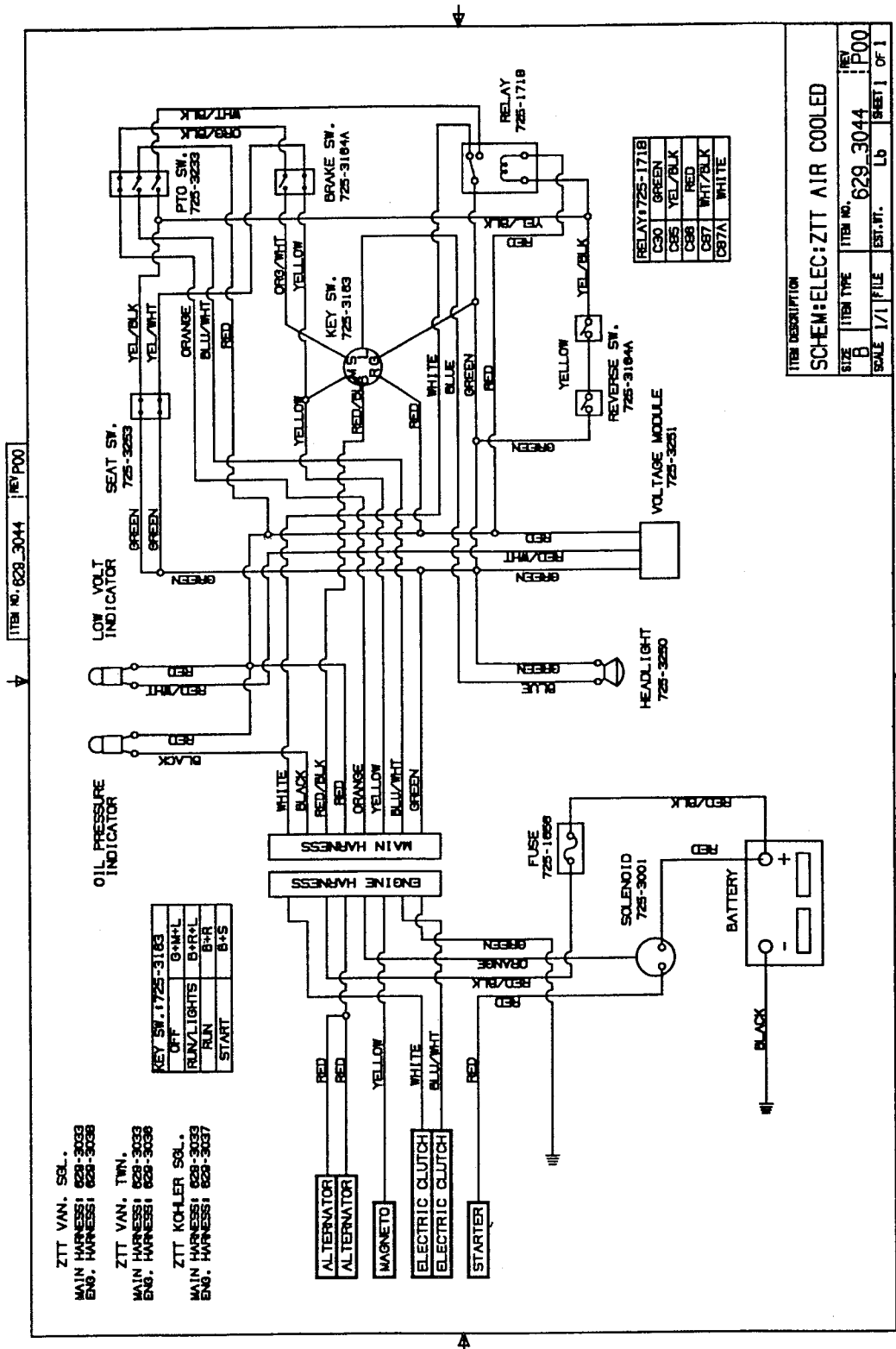
ITEM NO. 629\_0885 REV E00



MAIN HARNESS:  
629-03078

KEY SWITCH 725-1366	
OFF	B+M+A
RUN	B+L+A
START	B+S+L

ITEM DESCRIPTION  
**SCHEM: ELEC: 600: INTEL SW**  
 SIZE B ITEM TYPE 0 ITEM NO. 629\_0885 REV E00  
 SCALE 1/1 FILE EXT. INT. SHEET 1 OF 1



ITEM DESCRIPTION  
**SCHEM: ELEC: ZTT AIR COOLED**

SIZE	ITEM TYPE	ITEM NO.	REV
B	FILE	628-3044	P00
SCALE	1/1	EST. WT.	Lb
			SHEET 1 OF 1

## EVALUATING ELECTRIC CLUTCHES

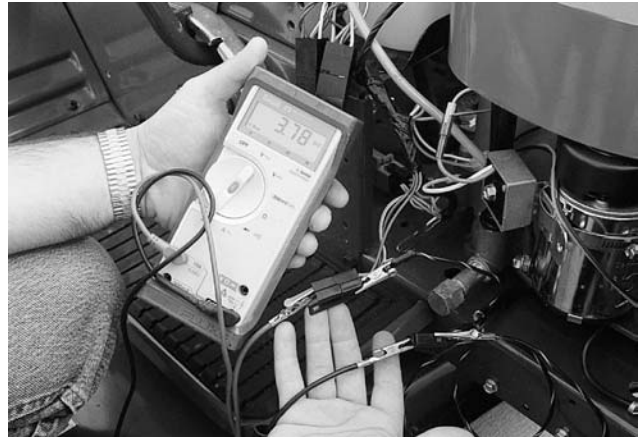
This section will cover how to evaluate electric clutches. You will need a multi meter to perform these tests.

1. To measure the clutch coil resistance, turn off the engine and the PTO switch.
  - a. Disconnect the clutch wire connection.
  - b. Set the meter to check ohms.
  - c. Connect the meter lead wires to the wires in the clutch connector. See Figure 3-42.



**Figure 3-42.**

- (1) If the meter reads below 2.40 ohms or above 3.40 ohms, the clutch has failed and needs to be replaced.
  - (2) If the meter reads between 2.40 and 3.40 ohms, proceed to measuring clutch current draw.
2. Set the meter to check amps using the 10 amp scale.
  - a. Connect one meter lead wire to one wire in the clutch connector and the other lead wire to the corresponding wire in the mating connector.
  - b. Connect a short wire to the second wire in both connectors. See Figure 3-43.



**Figure 3-43.**

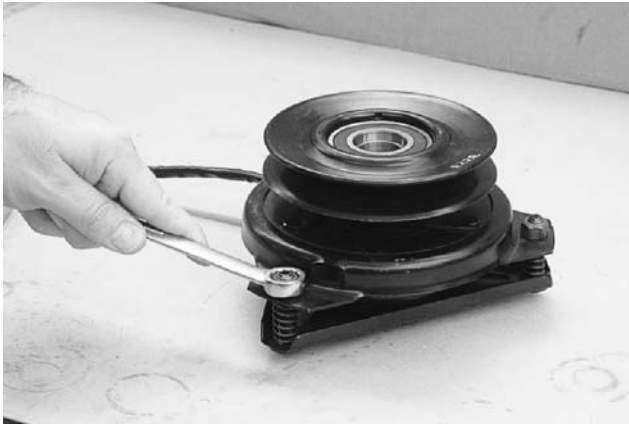
- c. Turn the PTO switch on.
  3. If the meter reads below 3.5 amps, the problem would be in the electrical system leading to the clutch such as the battery, a relay, or a switch.
  4. If the meter reads 3.5 amps or above, proceed to checking the air gap.
    - a. Turn off the PTO.
    - b. Locate the three windows or notches where the air gap is checked.
    - c. Check the gap at three locations using a feeler gauge.
    - d. The factory air gap setting is .010 to .025 inch. See Figure 3-44.



**Figure 3-44.**

- e. If the gap is incorrect, use a .017 feeler gauge and adjust the gap by tightening or

loosening the three nuts on the clutch. See Figure 3-45.



**Figure 3-45.**

5. The electric clutch initially needs to be burnished before it is used by the owner.

It is not done at the factory and is the responsibility of the dealer or the customer.

- a. To properly burnish the clutch, run the engine at 50 percent throttle.

- b. Engage and disengage the clutch 5 times, ten seconds on and ten seconds off.
  - c. Increase to 75 percent throttle.
  - d. Engage and disengage the clutch 5 more times, ten seconds on and ten seconds off.
6. If you have a unit with an electric clutch that operates sporadically, check all wiring around the steering column going to the dash for fraying and shorts.
    - a. Check the relays for proper connections. Newer models have in line relays to minimize vibration and reduce failure.
    - b. You can remove the relays from the chassis of older models and tape them directly to the wiring harness.
    - c. Check the PTO switch for proper connections. The red and blue wires might be reversed. The blue wire should be on top with the red wire directly below it. The brown wire should be on the opposite side.



# BELTS AND DRIVE SYSTEM

## 4-1. GENERAL.

4-1.1 V-belts are the most widely used means of power transmission. They are reliable, efficient and economical. This is especially so when they are compared with other methods of power transmission. Because they are so commonly used, they are often taken for granted. They are neglected and abused. Correct installation and maintenance are vitally important to their operating efficiency and life span.

1. The two major suppliers of V-belts are Gates and Dayco. Sometimes a service part will have the supplier's cardboard wrapper around it. Even with the wrapper, it means the V-belt meets our specifications which can vary from a standard V-belt. See Table 4-1.



### NOTE

Use original equipment belts for permanent installation. Anything else will only be temporary.

2. MTD Products, Inc. recommends the use of Original Equipment Manufacturer (O.E.M.) V-belts only. They are of special construction involving the type of cord, cord location and length. V-belts other than O.E.M. generally will only provide temporary service. For best results use only factory approved parts.

4-1.2 What is the difference in looks between a rayon cord, fractional horsepower V-belt and a Kevlar cord, oil and heat resistant V-belt designed to run up to 18 HP? To the untrained eye . . . NOTHING. The color of the rubber is just a dye to make the V-belt look different. Whether the V-belt has a cover or is bareback depends on the application not quality of the V-belt.

4-1.3 V-belt failures are normally not caused by a bad V-belt. The failed V-belt is usually the result of another part failing.

1. Prior to about 1974 V-belt problems were prevalent, especially on the cutting decks of the riding mowers. Several changes took place at that time with the design of the V-belt and the layout of the drive train.

2. About 95% of the V-belts used on MTD Products, Inc. units have a Kevlar cord. Kevlar cord was developed by DuPont and it is the strongest man-made fiber. Pound for pound it is stronger than steel. Two other uses of Kevlar are the belts in the nonsteel radial tires and bulletproof vests.



### WARNING

4-1.4 Standard V-belts will not have Kevlar cords. They probably will have a rayon or polyester cord. Rayon will not hold up as long as the Kevlar and the polyester could be dangerous because it SHRINKS when it gets hot. This could cause a clutch to engage when the control is in the disengaged position.

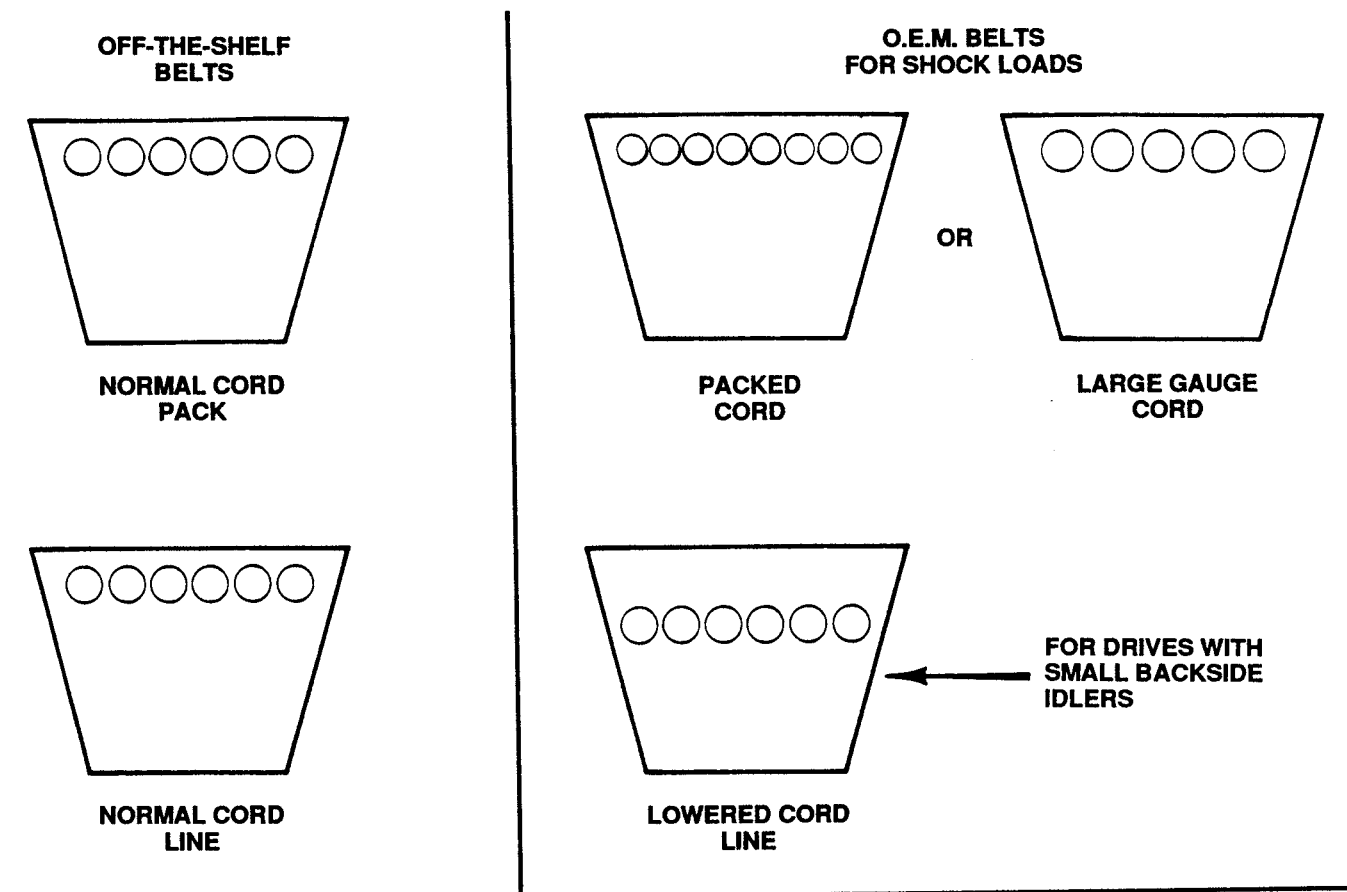
1. The belt may come off due to the pulley being damaged by driving over an obstruction, curb, root, tree stump, etc. Transmission and idler pulleys in particular can cause belts to come off. Also, misaligned idlers may be the cause of belts coming off. The same thing can happen when belts are assembled on the wrong side of a deck hanger or belt keeper, especially when shoulder bolts are used next to a pulley. It is easy to assemble the belt incorrectly on the outside of a belt keeper.
2. As you approach the repair the fact must be accepted that just putting on a new manufacturer's original belt may not always solve the problem. There may be other components that are causing the malfunction other than the belt(s).

4-1.5 As you proceed with repair, asking yourself questions may help. For example:

1. Normal wear. How many hours are on the mower? When was it manufactured? While the belt was wearing out, how many other components that the belt travels on were also wearing out? Poor operating habits. Jack rabbit starts and stops. Shifting into forward while unit is still rolling in reverse (every pulley, idler and



Table 4-1. V-Belt Descriptions



MATERIALS USED IN OFF-THE-SHELF BELTS	MATERIALS USED IN O.E.M. BELTS
<ol style="list-style-type: none"> <li>1. Filament polyester — Tensile Cords</li> <li>2. Rayon — Tensile Cords</li> <li>3. Rubber impregnated cover</li> <li>4. No crack stopper layers</li> <li>5. Wide length variation</li> <li>6. Single cover ply</li> <li>7. General purpose SBR under cord</li> <li>8. Non-fiber loaded under and over cord</li> </ol>	<ol style="list-style-type: none"> <li>1. Staple clutching polyester — Tensile Cords</li> <li>2. Kevlar — Tensile Cords</li> <li>3. Fiberglass — Tensile Cords</li> <li>4. Bareback non-rubber cover</li> <li>5. Crack stopper layers</li> <li>6. Tight length tolerance</li> <li>7. Two cover plies</li> <li>8. Full oil and heat resistance neoprene over and under cord</li> <li>9. Fiber loaded over and under cord</li> </ol>

<u>GATES ONLY</u>		
	<u>Cord</u>	<u>Color</u>
Type I:	Kevlar .....	Yellow
	Fiberglass .....	Red
	Polyester filament ..... (Various shrinkage)	Green/blue
Type II:	Polyester staple ..... (Less shrinkage nearer to Kevlar)	Brown
	Rayon (Out) .....	Tan/brown

gear must suddenly change direction). Incorrectly positioned belt guards: A guard too loose or too far away from a belt can be as bad as one that is adjusted too close. A guard must first be formed at the proper angle and adjusted to be as close as possible to hold a belt from coming out of a pulley but yet far enough, approximately 1/8 inch (as a rule), to allow the belt to trap-out. When the tension is removed from the drive system, it must assume a relaxed position; too tight can make the belt continue to drive for a time even though the drive system has been disengaged.

2. Are there indications that the belt was routed incorrectly? When does the belt come off the pulley? Does it happen only in reverse? The transmission mounts may not be tight or a torque bolt mounted in the front of the transmission may be loose. If the bolt has dropped out, the transmission is free to pivot back and forth. Therefore, when put into reverse, the front of the transmission pivots downward and the belt rolls off because the belt angle changed beyond the recommended specifications.

#### 4-2. PROPER STORAGE OF V-BELTS.

4-2.1 V-belts should be in a cool, dark place away from radiators and out of direct sunlight. Heat will dry out the belts and cause them to become hard and brittle.

1. Belts may be stored either by coiling them on shelves or in cartons—or by uncoiling and hanging them if shelf space is not available. If belts are hung, we recommend using wide support or multiple hooks so that the belts are not damaged by tight bending or excessive weight at a single point.
2. Under normal conditions (temperatures below 85°F, relative humidity below 70% and no direct sunlight) V-belts can be stored as long as six years without damage. Beyond that point, still under normal conditions, a decrease in service life of approximately 10% per year of storage can be expected. Storage limit should be reduced one-half for each 15 degree increase in temperature (three years at 100°, for example).

#### 4-3. CAUSES OF V-BELT PROBLEMS.

4-3.1 V-belts are used on an untold number of different power units. Application varies from manufacturer to manufacturer. Yet, the cause of the belt problems remains basic to all. The following is a list of causes which may help spot potential trouble.

1. Normal wear. If a belt loses its effectiveness after a prolonged period of use, its failure can generally be accepted as normal wear. Replacement of the belt with the correct type and size is all that is required.
2. Poor operating habits. Although V-belt failures can often be attributed to normal wear, many failures are in no way the fault of the belt. Under these circumstances, replacement of the belt will simply result in another rapid belt failure. Failure will continue until the real cause is diagnosed and corrected. One such case is incorrect operation. When an idler pulley is used in the system and excessive and rough clutching occurs, severe reduction of the service life of the belt will be experienced. Failure will continue until the incorrect method of operation is changed.
3. Damaged or worn idlers. Frozen idler bearings will cause much the same results as excessive or rough clutching. When a frozen idler bearing is encountered, it is not only necessary to replace the idler but also the belt. Heat damage will severely reduce the service life of a belt. Where an idler is involved, heat damage will cause polyester belts to shrink considerably.
4. Incorrectly positioned belt guards. Belts frayed or worn on the outside indicate incorrectly mounted belt guards, belt guides or belt clips. Damaged guards should be replaced. Incorrectly positioned guards should be realigned. Guards should be mounted close to the tightened belt but they must never touch the tightened belt.
5. Damaged or worn pulleys. Belts frayed or worn on the inside indicate defective or damaged pulleys. Belts are designed to grip the smooth

flat inner sides of a pulley. Pulleys can be the cause of belt failure for the following reasons:

- a. The pulley is too wide for the belt and allows it to bottom. Except on deep groove pulleys, belts should generally ride even with or above the outside edges of the pulley.
  - b. The inner surface of the pulley is wrinkled, worn, rusted, dirty or nicked. Wrinkled and worn pulleys should be replaced. Rusted, dirty or nicked pulleys should be polished or replaced.
6. Misaligned pulleys. Belts which break or tend to jump from the pulleys indicate incorrect alignment. Although incorrectly adjusted belt guards can contribute to the problem, alignment of the pulleys should be checked. Except where an off-set system is used (on some blade drives) all pulleys and idlers should be on the same level or plane. Offset systems are designed with special pulleys to compensate for a certain amount of misalignment. Where set screws are used for fastening, they must be tightened securely. A nut and bolt sealant applied to the set screws will assure lasting tightness.
  7. Incorrect tension. A squealing noise during acceleration, loss or lack of power, belt cover wear, burn spots and overheating all indicate insufficient belt tension. Insufficient belt tensions result in belt slippage. Normally, belt slippage results when a belt stretches excessively due to long hard use. Where this is the case, only replacement of the belt is required. Often, however, the cause is other than normal wear. Insufficient spring tension on the idler bracket is a common problem. The spring may have weakened or it may be an incorrect spring. Replacement should be made with a spring which provides adequate tension. Springs should also be lubricated with light oil to prevent rust and to provide free spring movement. Idler brackets which do not pivot freely can also be a problem. They may be just fastened too tight or they may lack lubrication at the pivot point. Incorrect shoulder screws can also be a cause for idler brackets to be excessively tightened. Failure to recheck adjustment after installation of a new belt can also result in slippage. Some time after the initial adjustment of

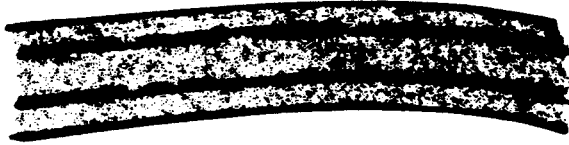
a new belt, a follow up adjustment may be necessary. The reason for this is that some slack may develop during the 48 hour break-in period. Excess tension is only found in systems which do not use idler pulleys or in systems where too strong an idler pulley spring is used. Broken belt cords, excessive stretch and rapid belt failure can indicate excessive belt tension.

8. Oil and grease damage. Belt damage from oil and grease will be detected as belt slippage. Oil and grease also cause belts to deteriorate. Clean belts with a volatile solution. Oil soaked belts should be replaced immediately. Oil leakage should be eliminated promptly. If oil is a continuing problem, consider oil resistant belts.
9. Heat damage. When belts operate at temperatures of 140°F or higher, heat aging takes place. This condition can be created by belt slippage or by routing belts too close to heat producing assemblies such as mufflers. Polyester belts operating with an idler and subject to a heat problem will shrink severely on cooling. Where the problem cannot be remedied, heat resistant belts should be considered and polyester belts should be avoided.
10. Incorrect installation. Belts must be installed with care. Never use force when installing a belt. Sometimes it becomes necessary to remove a pulley or belt guard to eliminate the use of force but the extra time necessary is well spent. The tension on newly installed belts should be rechecked after 48 hours use. A certain amount of slack can develop during this break-in period.

#### **4-4. V-BELT PROBLEMS WITH ROTARY TILLERS, SELF-PROPELLED MOWERS AND RIDING MOWERS.**

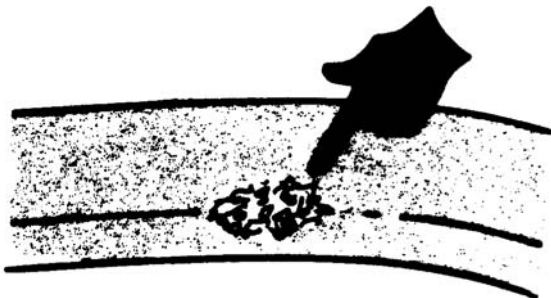
4-4.1 One of the most common problems encountered with rotary tillers, self-propelled mowers and riding mowers involves damaged or broken V-belts. Regardless of the type unit involved, the causes of the problem usually remain the same.

1. If a belt fails after an extended period of use, failure is probably due to normal wear. Replacement of the belt is all that is necessary. See Figure 4-1.



**Figure 4-1. Belt Wear Due to Normal Life**

2. If a belt becomes inoperative after an insufficient period of service, failure usually is the result of incorrect operation. Excessive engaging and disengaging of the clutch, especially where an idler pulley is used, will definitely reduce the service life of the belt. Replace belt and correct operational methods. Damaged idlers or frozen idler bearings will cause rapid belt wear. Replace idler or its bearing.
3. If belt frays or wears on the outside, incorrectly mounted belt guards and belt clips usually are at fault. Replace belt and reposition belt guards and belt clips. These should be positioned close to the belt. But when the clutch is engaged and the belt is tightened, belt guards and belt clips must not touch the belt. See Figure 4-2.



**Figure 4-2. Belt Wear Due to Interference**

4. If belt frays or wears on the inside, defective pulleys are at fault. The V-belt should ride on the smooth inner sides of the pulley. Pulleys which are spread apart allow the belt to ride on the bottom and rapid belt wear is the result. If the belt rides below the outside edges of a pulley, chances are good that the pulley is spread. Replace pulley. Rough spots or nicks on the inside surface of pulley will result in premature belt wear. Polish inside of pulley or replace pulley. See Figure 4-3.
5. If belt breaks prematurely or tends to jump from pulleys, incorrectly aligned pulleys may be at fault. All pulleys including the idler should

be on the same plane. (This does not apply to blade belts on level adjusted floating decks. The misalignment in this case is compensated for by a special engine pulley.) Pulleys should be realigned and set screws fastened securely. A nut and bolt sealant applied to the set screw will assure lasting tightness.



**Figure 4-3. Belt Wear Due to Misalignment or Worn Pulley Groove**

6. Other belt problems are encountered because of excessive shrinkage, excessive stretch or oil and heat damage such as shock load and flex failure. See Figures 4-4 and 4-5.



**Figure 4-4. Belt Damage Due to Shock Load**



**Figure 4-5. Belt Damage Due to Flex Failure**

7. All belt replacements should be made with belts of the same size and type as those furnished with the original equipment.

#### **4-5. PULLEY ALIGNMENT.**

- 4-5.1 Check alignment as follows:

1. Make sure that the drive shafts are parallel by using a measuring tape to measure the distance between the shafts both at the outside pulley and the inside of the pulley. Shafts that are parallel will be the same distance apart at both points.
2. Tie a string to the drive shaft and pull taut across the pulleys. If the pulleys are properly lined up, the string will touch them at the points indicated by the arrows. By rotating each pulley through one-half revolution, you can also determine whether pulley is wobbly or the drive shaft is bent. If either of these conditions exists, the inner rim of the pulley will pull away from the string when the pulley is rotated. See Figure 4-6.

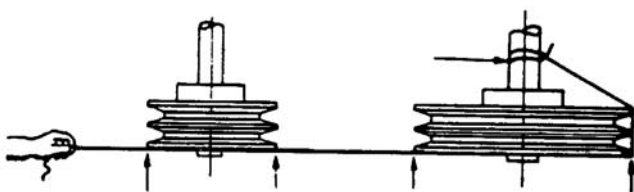


Figure 4-6. Pulley Alignment



Pulleys that are not properly aligned cause excessive belt and pulley wear. Where shafts are not parallel, belts on one side are drawn tighter and pull more than their share of the load. As a result, these belts wear out faster, causing the entire set to be replaced before it has given maximum service. If misalignment is in pulley only, belts will enter and leave grooves at an angle, causing excessive cover and pulley wear. See Figure 4-7.

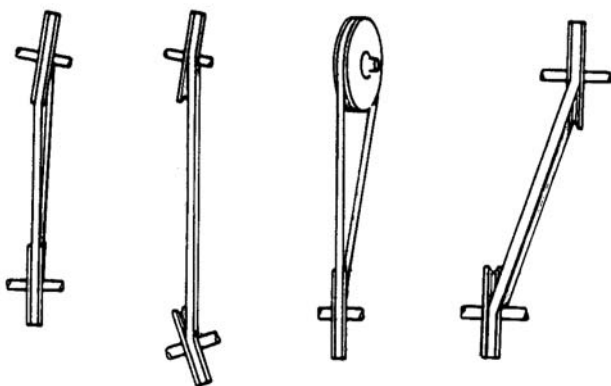


Figure 4-7. Pulley Misalignment

#### 4-6. IDLERS.

4-6.1 Idler Problems. As necessary as idlers are, they tend to be a problem in a drive system. They should be checked frequently. These problems are more or less expected on a mower that has been used for a period of time but what does one look for when a belt problem is experienced on a new rider or tractor? Problems can be more difficult to find on a new unit because alignment appears to be correct, and the wear or age factors of course are not present, but the remaining thoughts expressed are still possibilities. A review of these basic considerations will reveal the problem and save much time.

#### 4-6.2 Damaged or worn idlers.

1. Frozen idler bearings that cause a restriction on the belts building up a heat factor. This can cause a belt to shrink or weaken and stretch. When the belt is hot it will tend to roll over.
2. Wherever there is an idler, it is usually attached to a pivoting idler bracket. The pivot point of the bracket often reflects the problem by being loose. On riding mowers, the pivot points have a bearing or nyloner bushing which may be worn out or restricted by rust or corrosion.
3. Pulley halves can separate because of a defective weld. Pulleys do not run true if the groove is not formed right or is damaged.

#### 4-6.3 Idlers are used for various reasons:

1. To provide an adjustment for fixed central drives.
2. To clear obstructions.
3. To turn corners.
4. To break up long spans where belt whip may be a problem.
5. Maintain tension when the idler is spring loaded.
6. To increase arc-of-contact on a critical loaded pulley.
7. To clutch certain types of drives (transmission clutching, blade engagement, all types of power take-off on various chore performing equipment).

**4-7. GENERAL.**

4-7.1 The variable speed pulley can best be described as a torque converter. It is used on some riding mowers, rotary tillers and tractors. The variable speed pulley allows you to vary the ground speed (or the tiller speed) while maintaining a constant engine speed. We use a smaller one on the riders and the larger one on the tractor and rear tine tiller. Coupling the transaxle with the variable drive system you

have the ultimate drive train. With this total drive system you can set the speed selector for a given speed, then slow down for a turn (cutting around trees or flower beds), by pushing in on the clutch/brake pedal. Release the pedal and the tractor automatically resumes the set speed. This type of drive system permits no-clutch-on-the-go speed control and enables you to match your ground speed to your mowing conditions without slowing the RPM's of the cutting blade. See Figure 4-8.

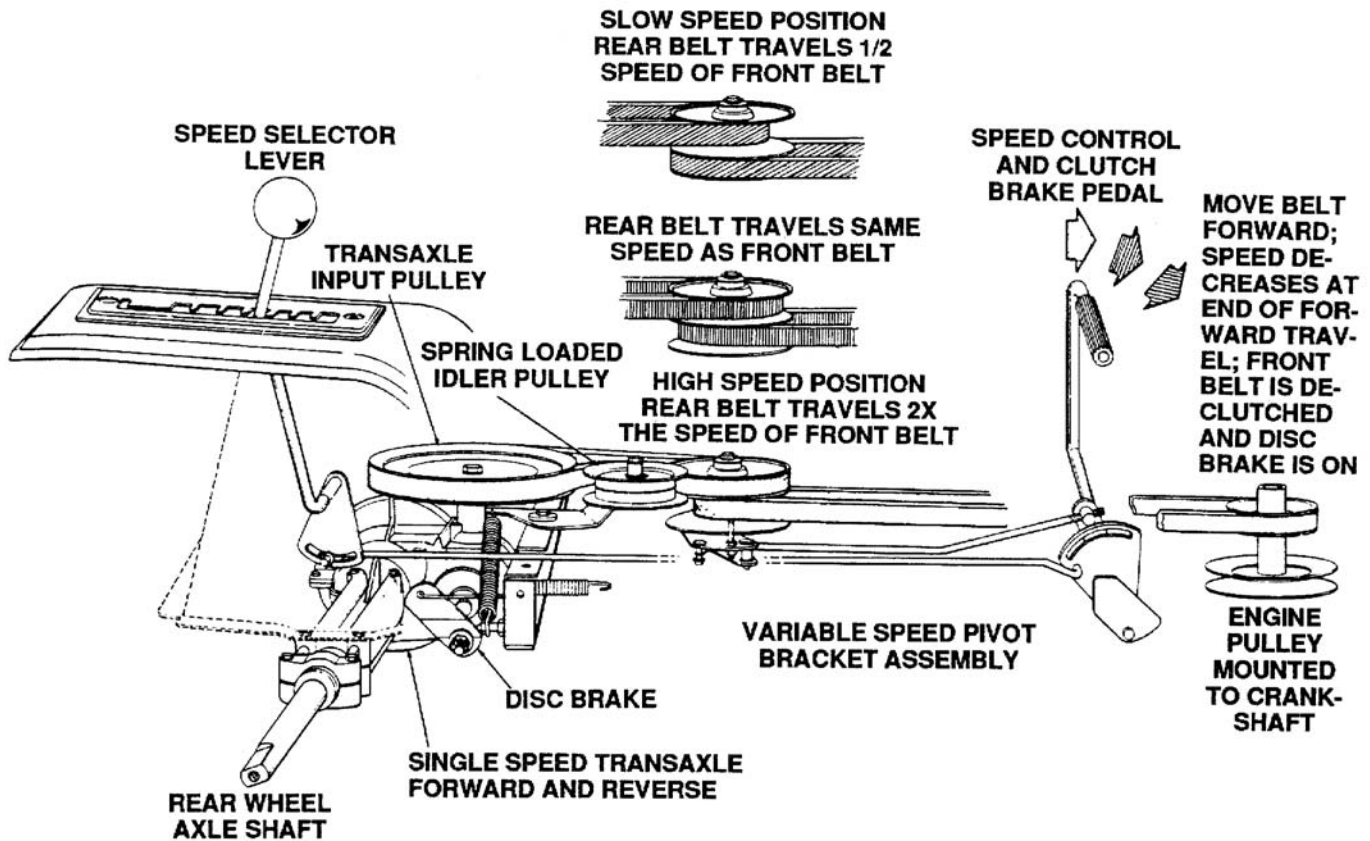


Figure 4-8. Variable Drive System

4-7.2 The drive principle for the new two speed transmission is similar to the single speed drive system. The variable speed pulley, combined with the two speed transmission, allows 14 ground speeds: 7 low range and 7 high range. Each speed is obtained by the placement of the shift lever and speed control lever. See Figure 4-9.

**➔ NOTE**

On 1989 and 1990 units only, the shim used under the clutch brake pedal assembly is 5/8 inch instead of 1/2 inch as marked for the speed control adjustment.

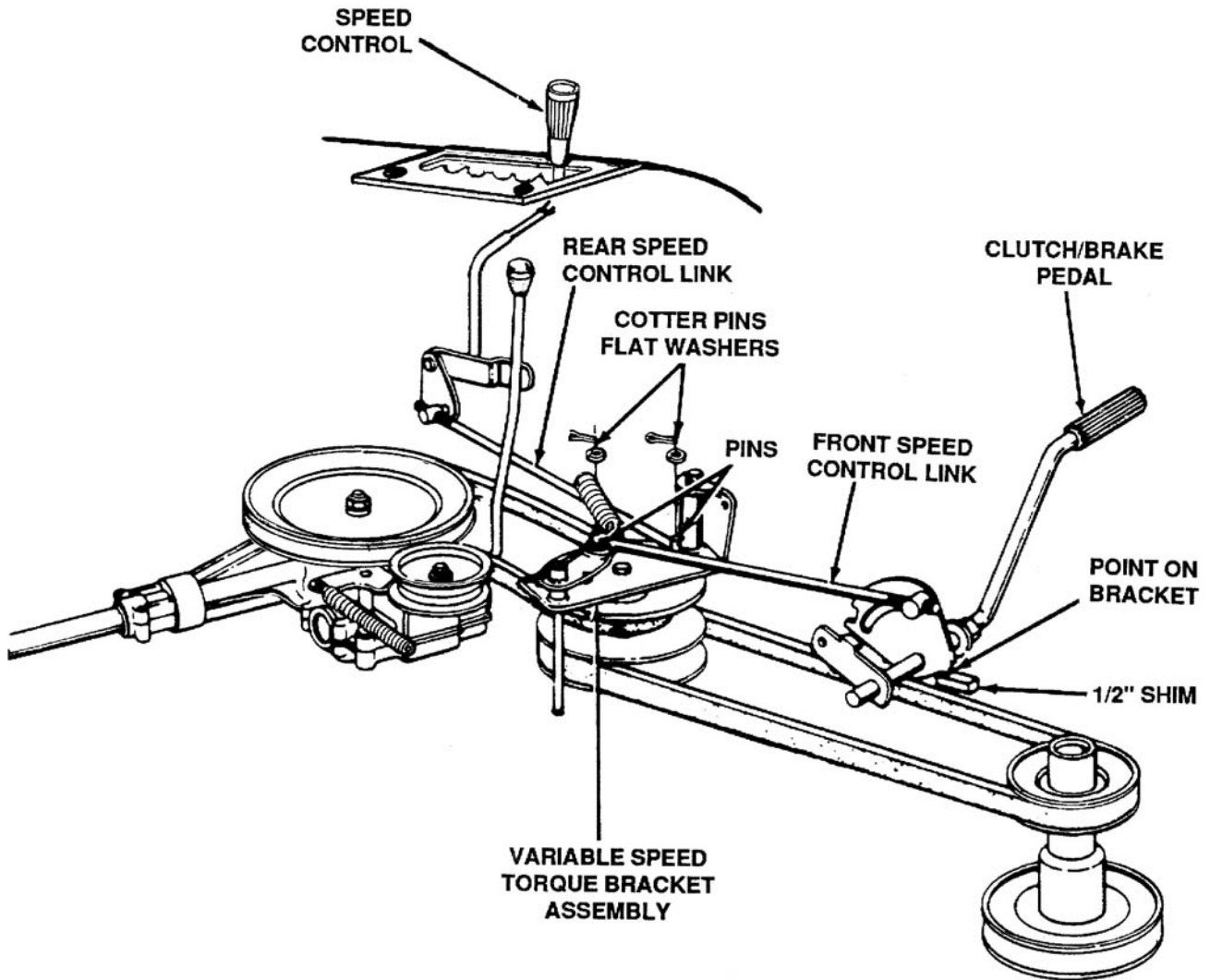


Figure 4-9. Two Speed Transmission

4-7.3 Riding Mowers have a variable speed pulley that is used with the single speed transmission. This gives you a multispeed drive, and the transmission gives you reverse as well as changing the plane of the drive. Tractors use a variable speed pulley that is between the engine and the four speed transaxle. This gives you a speed variation in each gear. As the variable speed pulley moves away from the engine pulley, the engine V-belt pulls towards the center of the variable speed pulley, pushing the movable sheave up. This forces the transmission V-belt to the outside of the variable speed pulley. A mechanical lock of the control linkage can stop the variable speed pulley at any point. See Figure 4-10

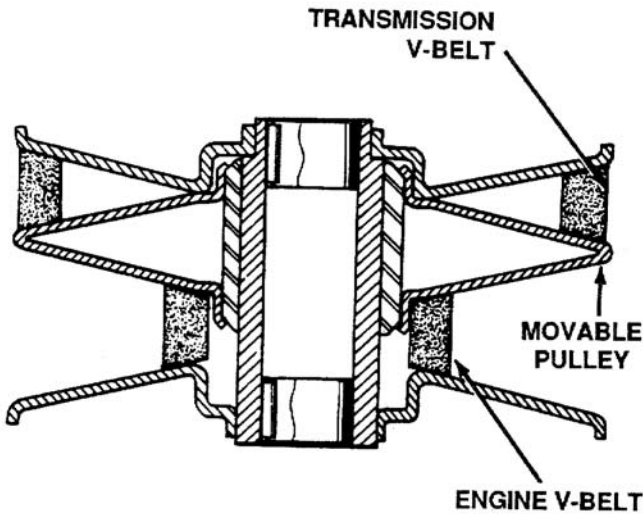


Figure 4-10. Horizontal Variable Speed Drive Pulleys

4-7.4 Tillers use a variable speed pulley that is placed between the engine and the chain cage. By moving the control lever you can vary the tine speed. See Figure 4-111.

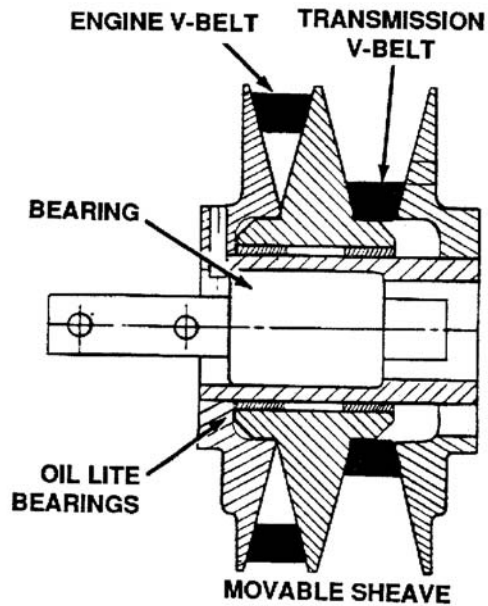


Figure 4-11. Vertical Variable Speed Drive Pulley

**NOTE**

Notice the difference between the horizontal (Figure 4-9) and the vertical (Figure 4-11) variable speed drive pulleys.

**4-7.5 Maintenance of Variable Speed Pulleys.**

1. **Testing.** The movable sheave must be able to slide easily sideways but cannot be loose. If the movable sheave is too loose it will cock and will not slide when under load.
2. **Repair.** The needle bearings on the riding mower variable speed pulley can be replaced. These are the only parts available for repair. The part number is 741-0404.
3. **Lubrication.** Lubricate the needle or ball bearings once a year with a few drops of engine oil.

**CAUTION**

Excessive oiling will get on the V-belts and deteriorate them, or cause slippage.

4. Use a rag to clean dirt and rubber from the V-belt from the groove.



- 4-7.6 The shift lever generally has three positions: forward, neutral and reverse, except on the new two speed transmission which has high, low, neutral and reverse. The clutch/brake pedal must be depressed and the lawn tractor must not be moving when shifting gears. Do not force the shift lever. Release the clutch/brake pedal slightly to line up the shifting collar in the transmission. Then try to shift gears.
- 4-7.7 The speed control lever allows you to regulate the ground speed of the lawn tractor. To select the ground speed, depress clutch pedal. Push speed control lever outward and move backward to slow lawn tractor; move forward to increase speed. When desired speed has been obtained, release lever in that position. Whenever clutch is engaged, unit will automatically go to the preset speed.
- 4-7.8 The clutch/brake pedal is located on the left side of the lawn tractor. Depressing the clutch/brake pedal part way disengages the clutch. Pressing the pedal all the way down disengages the clutch and engages the disc brake.

#### 4-8. FOUR WHEEL STEERING.

- 48.1 The drive system for the four wheel steer models remain the same as has been previously out-lined in Section 4-7.

This is a variable speed pulley principle successfully used on 600 and 700 Series riders and lawn tractors. Coupling this variable drive system with the all new transaxle model 717-1287 adds to the unique maneuverability of the four wheel steering by being able to control just the right ground speeds for comfortable operations. See Figure 4-12.

- 4-8.2 The four wheel steering lawn tractor is designed for optimum maneuverability. It is important to understand how it operates before using the lawn tractor. If the wheels are pointing straight forward and the steering wheel is turned less than approximately 45 degrees, only the front wheels turn. See Figure 4-13.

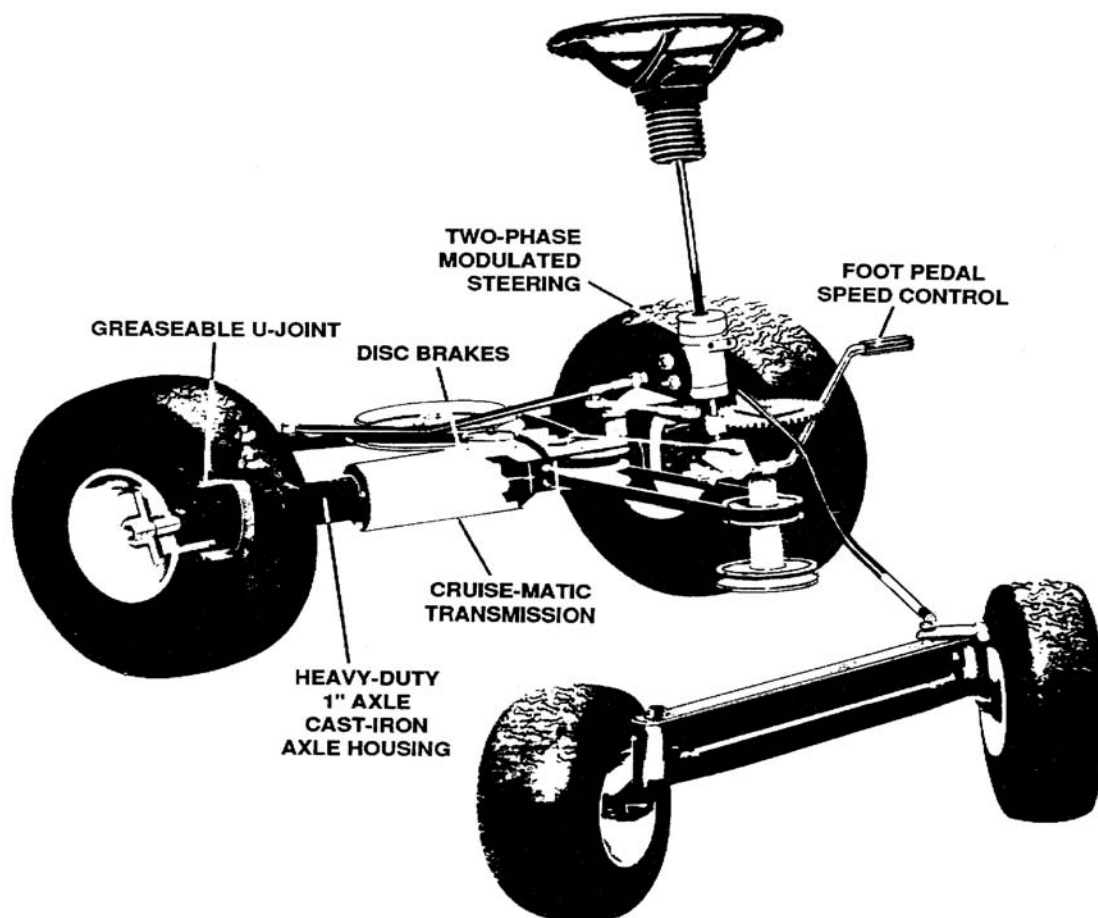
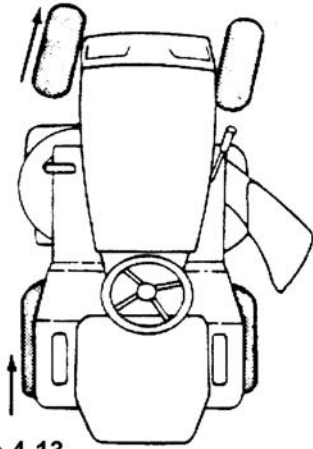
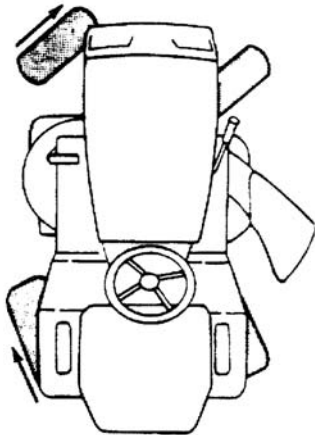


Figure 4-12. Four Wheel Steering



**Figure 4-13.**  
**Less Than 45 Degree Turn of Steering Wheel**

When the steering wheel is turned sharply more than approximately 45 degrees, the rear wheels also turn, but in the opposite direction as the front wheels to provide a very small turning radius. See Figure 4-14.



**Figure 4-14. More Than 45 Degree Turn of Steering Wheel**

**NOTE**

The front wheels will turn approximately 15 degrees before the rear wheels begin to turn in the opposite direction.

**WARNING**

If operating this lawn tractor near a drop-off in the ground, DO NOT make a sharp turn. The rear wheel turns outward and could lose ground contact which could cause the vehicle to tip over.

**CAUTION**

When operating the lawn tractor beside a wall or fence, against or on top of a curb, driving around an object or in any other similar situation, turn the steering wheel gradually to pull away from the object or curb so the rear of the tractor does not swing out and hit the object or go over the curb.

4-8.3 Four wheel steering makes operating in confined areas easier to perform and is time saving. Four wheel turning itself has been available for some time. We have taken this popular concept one step further with our 2-phase four wheel steering as follows:

1. With this new type of steering, the rear wheels turn in opposite direction of the front wheels after a slight delay. This delay reduces the turning radius to a remarkable 12 inches compared to the industry standard of 24 inches.
2. This extra turning power is a big help when it comes to maneuvering around trees, shrubs and other natural obstacles.
3. The delay rear wheel movement also greatly reduces the change of striking walls, fences, flower beds, etc. with the rear wheels while negotiating a turn.

4-8.4 Four Wheel Steer Rear Axle Assembly (Figure 4-15).

**CAUTION**

If for any reason you have to disassembly the steering boom, steering ink and tie rod assembly, mark the threads so that you can reassemble the parts properly to avoid steering problems.

**NOTE**

Early production models had problems with the axle bolt coming out. The shaft is now welded to the hub. The bolt is still in place.

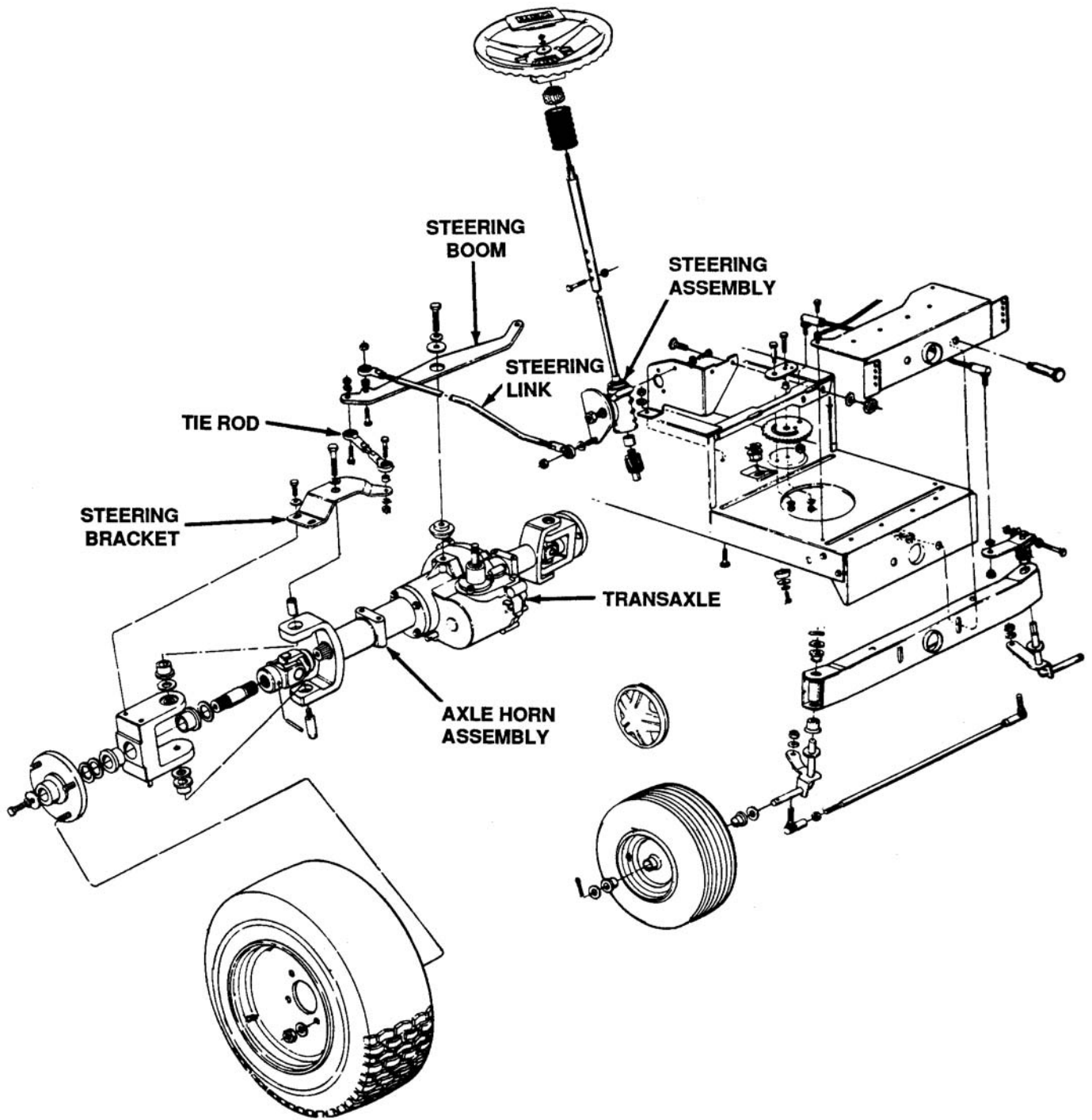


Figure 4-15. Four Wheel Steer Rear Axle Assembly

**NOTE**

The hub and shaft are available ONLY as a complete assembly (part number 717-1298).

4-8.5 Adjust four wheel steering as follows:

1. Locate the hole in the steering segment gear and retainer plate by moving the steering wheel. When the two holes line up, install a small rivet to secure proper front wheel alignment. If the front wheels are not straight at this time, adjust the steering drag bar.
2. With the front wheels in the locked forward position locate the neutral position in the steering arm assembly by moving the steering wheel approximately 16 degrees in each direction until you can insert a small rivet through the hole under the grease fitting of the steering arm and

into the cam shaft assembly. This will lock out the steering arm assembly and rear wheels.

3. Adjust the steering link from the steering arm assembly to the steering boom. This will allow even adjustment for both rear tires. If one rear tire is straight and the other is not, adjust only the tie rod between the steering boom and steering bracket.

4-8.6 Disassembly of Four Wheel Steering.

Disassemble four wheel steering assembly as follows:

1. Remove steering arm assembly, seal retainer and seal by removing the lock nut on the pivot shaft. At this time, the pivot shaft and flat washer can be removed from the steering gear housing. The housing bushings must be pressed out for replacement. See Figure 4-16.

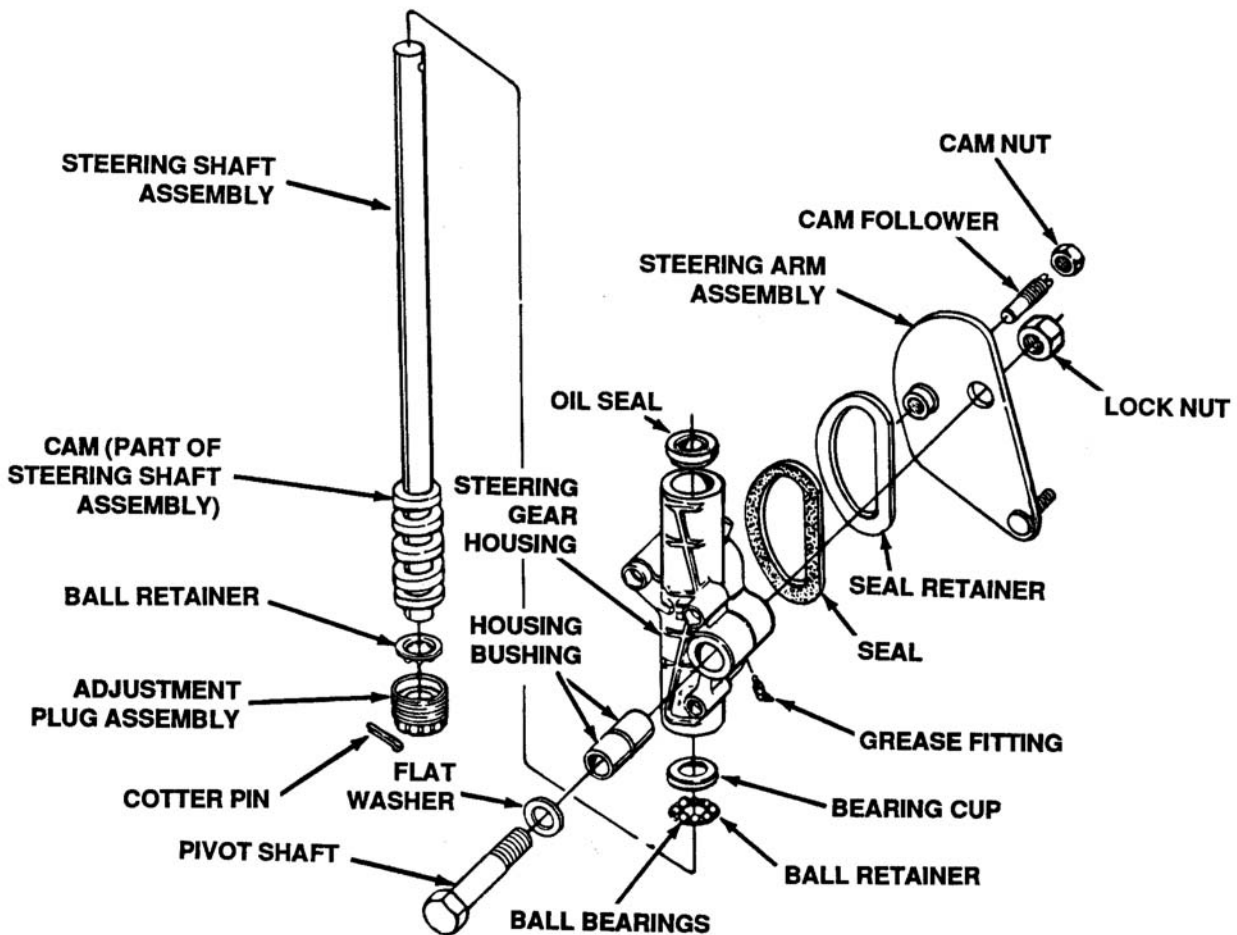


Figure 4-16. Four Wheel Steering Assembly

 **NOTE**

The jam nut and cam follower can be removed from the steering arm assembly. This is not a necessary step for removal of steering arm assembly. You can also inspect the cam and steering shaft inside the steering gear housing.

2. Remove the steering shaft assembly by removing the cotter pin, adjustment plug, ball retainers with ball bearings and bearing cap. Slide steering shaft assembly through bottom of steering gear housing.

 **NOTE**

There are eight ball bearings in each ball retainer. Each ball bearing can be ordered separately (part number 741-3122).

3. Remove oil seal from upper steering gear housing assembly by using an arbor press. Remove the oil seal by placing a spacer or similar tool on the OD of the seal and press the seal out.

 **NOTE**

To reinstall a new seal, use an arbor press to properly position seal in gear housing assembly.

4. Inspection. Wash all parts in cleaning solvent and dry thoroughly before inspection.
  - a. Inspect the cam follower for wear (flat spots).
  - b. Inspect the cam ends, ball retainers with ball bearings and bearing cups for wear, roughness and pitting.
  - c. Inspect the cam grooves for wear, roughness and galling.
  - d. Inspect the housing for cracks and stripped threads.
  - e. Inspect the upper oil seal for wear or damage.
5. Reassembly.
  - a. Thoroughly coat the cam ends, ball retainers with ball bearings and bearing cups with No. 251 lithium base grease or order part number 737-3007.

 **NOTE**

Be sure the bearing cups enter the housing squarely.

- b. Install the bearing cups and ball retainers with ball bearings on the steering shaft assembly cam ends.
- c. Thoroughly coat the cam with chassis lubricant and install into the steering gear housing assembly.
- d. Install the adjustment plug. Screw the plug inward until end play of cam is removed but turns freely. Insert the cotter pin in the nearest hole.
- e. Fill the housing with 4 oz. No. 251 lithium base grease or order part number 737-3007.
- f. Loosen the cam follower jam nut, then back out the cam follower two turns.
- g. Install the seal, seal retainer, washer and pivot bolt assembly to the housing.
- h. Install and tighten the lock nut sufficiently to provide good seal compression. The adjustment dimension is approximately 3/32 inch between the steering arm assembly and the steering gear housing. Tighten lock nut to 40 ft-lbs. Lubricate at the grease fitting in the housing slowly until lubricant begins to seep out.
- i. Center the steering cam by rotating the steering shaft assembly half way between full right and full left turn.
- j. Adjust the cam follower inward to eliminate backlash and tighten jam nut to 40 ft-lbs. Turn steering shaft assembly full right and left to check for binding.

 **NOTE**

If a customer complains of steering backlash, first center the steering assembly. At that point you will feel the neutral backlash. Loosen the jam nut and turn the steering shaft past the neutral position and tighten the cam follower to eliminate the backlash. Tighten the jam nut to 40 ft-lbs.

**4-9. GENERAL.**

- 4-9.1 During normal operation of this machine, the brakes are subject to wear and will require periodic examination and adjustment.



## WARNING

Do not adjust the brake while the engine is running. Be sure to block the wheels of the tractor before making the brake adjustment.

### 4-10. BRAKE ADJUSTMENT ON 300, 400, 500 SERIES AND 600 AND 700 SERIES, MODELS 1989 AND PRIOR.

4-10.1 The brake is located by the left rear wheel inside the frame. On the 600 and 700 series, 1989 and prior, it is located on the right hand side.

4-10.2 Brakes can be adjusted using a .010 feeler-gauge.



## NOTE

Prior to 1990, brake pins could rust causing the brake to stick slightly. If grass collects on the brake, they can overheat and smoke. If this happens, take the brake apart and clean and lubricate the actuating pins. In 1990 the new assembly was made with aluminum parts that helped prevent the problem.

4-10.3 To adjust the brake, remove the cotter pin. Adjust the castle nut so the brake starts to engage when the brake lever is 1/4 to 5/16 inch away from the axle housing. See Figure 4-17.

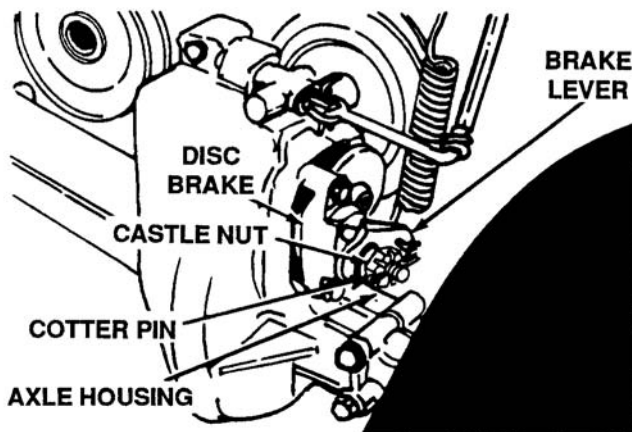


Figure 4-17. Brake Adjustment Models 300, 400, 500 Series and 700 Series, Models 1989 and Prior

### 4-11. BRAKE ADJUSTMENT ON 600 AND 700 SERIES, FOUR WHEEL STEER.

4-11.1 Adjust brake as follows:

1. Remove the cotter pin. Tighten the castle nut by hand until the brake lever locks against the bracket on the transaxle. See Figure 4-18.

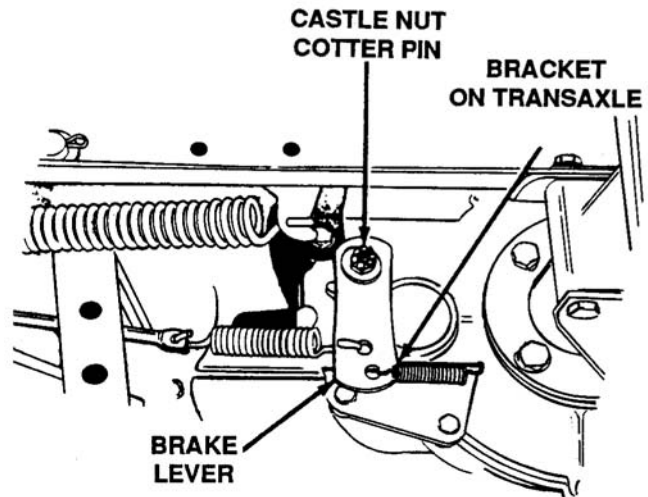


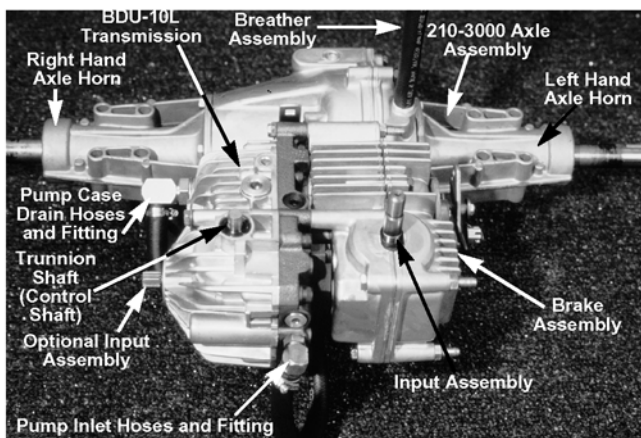
Figure 4-18. Brake Adjustment 600 and 700 Series, Four Wheel Steer

2. Push clutch/brake pedal forward until resistance is felt. Adjust the speed control link in or out until it fits over the pin on the torque bracket. Then shorten two full turns. Secure to pin on torque bracket using flat washer and cotter pin.
3. Back the castle nut on the brake off 1 or 2 notches until the hole in the brake mounting pin aligns with a slot in the castle nut. Secure with cotter pin.



# HYDROSTATIC

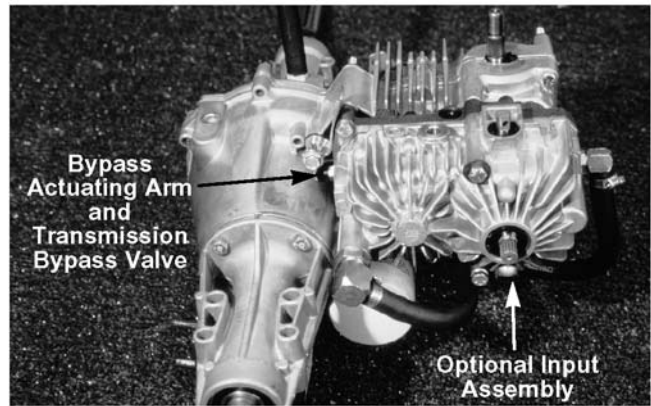
1. Shown is Hydro-Gear's 210-3010L (Heavy Duty Hydrostatic Transaxle). It is designed for use on consumer yard tractors and garden tractors. See Figure 5-1.
2. External components consist of:
  - A. Input assembly.
  - B. Optional input assembly.
  - C. Trunnion shaft (control shaft).
  - D. Brake assembly.
  - E. Breather assembly.
  - F. Pump inlet hoses and fitting.
  - G. Pump case drain hoses and fitting.
  - H. 210-3000 Axle assembly.
  - I. BDU-10L Transmission.
  - J. Left hand axle horn.
  - K. Right hand axle horn. See Figure 5-1.



**Figure 5-1.**

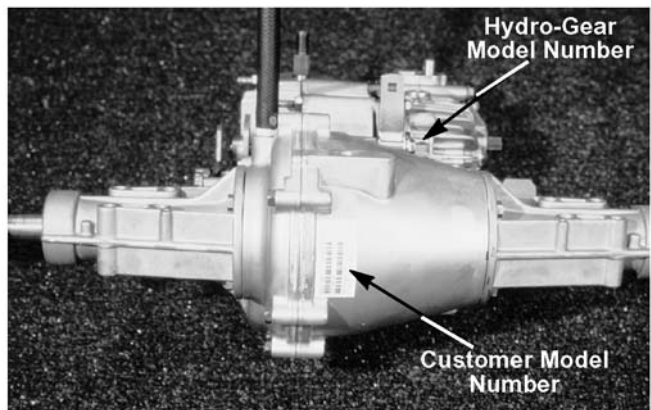
**Figure 5-1**

3. Here is another look at some of the external components:
  - A. Bypass actuating arm and the transmission bypass valve.
  - B. Optional input assembly. See Figure 5-2.



**Figure 5-2.**

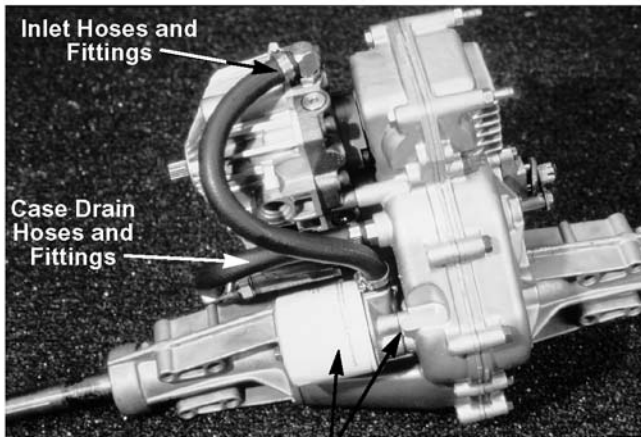
4. Shown here is Hydro-Gear's identification tag for the 210-3010L. It provides the following essential information:
  - A. Customer model number.
  - B. Hydro-Gear model number (starts on serial date "6275" (10 Oct. 96)).
  - C. Serial number. See Figure 5-3.



**Figure 5-3.**

5. Continuing on with identification of the external components:
  - A. Inlet hoses and fittings.
  - B. Case drain hoses and fittings.
  - C. Filter, filter base, and the filter base gasket. See Figure 5-4.

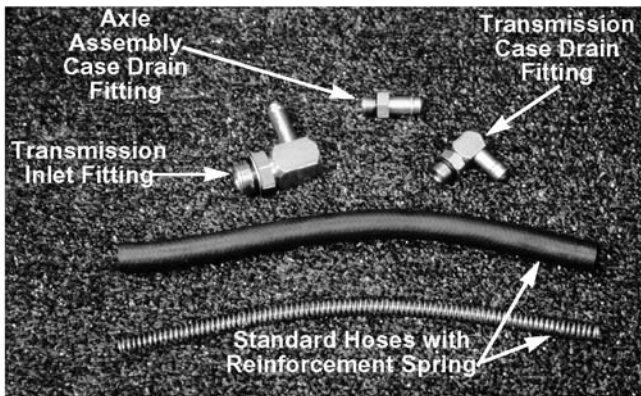




**Filter, Filter Base and Filter Base Gasket**

**Figure 5-4.**

6. Shown here are the inlet and case drain hoses and fittings:
  - A. Transmission inlet fitting.
  - B. Axle assembly case drain fitting.
  - C. Transmission case drain fitting.
  - D. Standard hoses with reinforcement spring. See Figure 5-5.



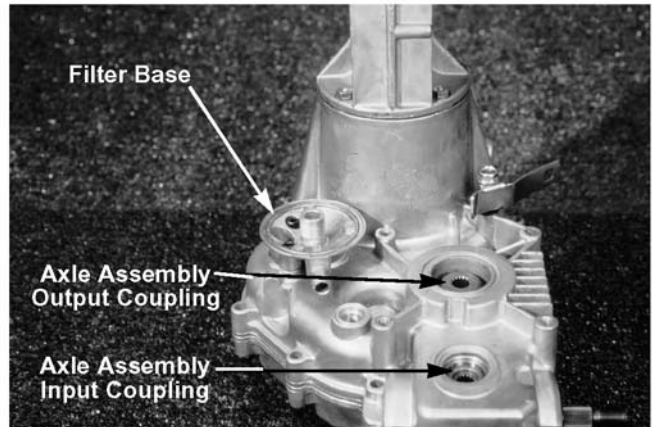
**Figure 5-5.**

7. Shown here is the filter. (40 micron). See Figure 5-6.



**Figure 5-6.**

8. Once the transmission is removed from the axle assembly you can identify these components on the axle assembly:
  - A. Axle assembly input coupling (from the axle assembly to the transmission).
  - B. Axle assembly output coupling (from the transmission assembly to the axle).
  - C. Filter base (filter removed). See Figure 5-7.



**Figure 5-7.**

9. Shown here is the:
  - A. Filter base.
  - B. Filter base gasket. See Figure 5-8.

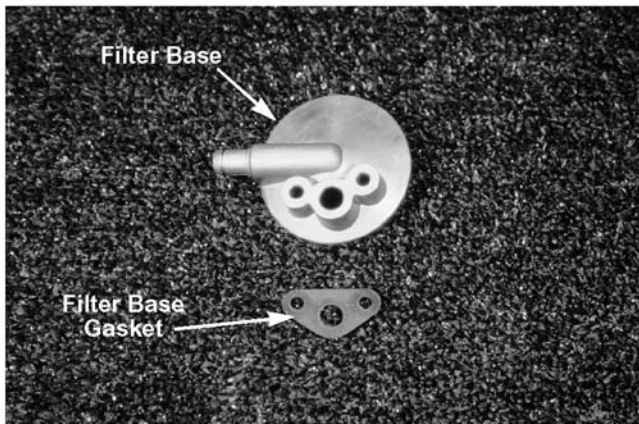


Figure 5-8.

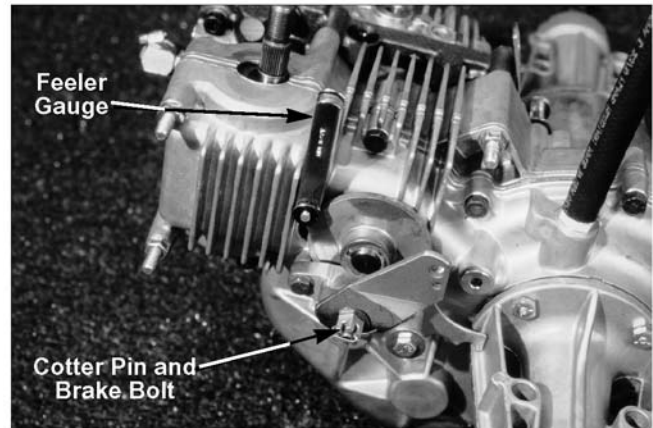


Figure 5-10.

10. Here is a view of the left hand axle horn assembly after removal from the axle. We can inspect these areas on the axle horn assembly:

- A. Axle horn housing.
  - a. Alignment tab.
  - b. Mounting bolt holes.
- B. Retaining ring, standard washer, and the slotted washer.
- C. Ball bearing.
- D. Axle shaft (splines). See Figure 5-9.

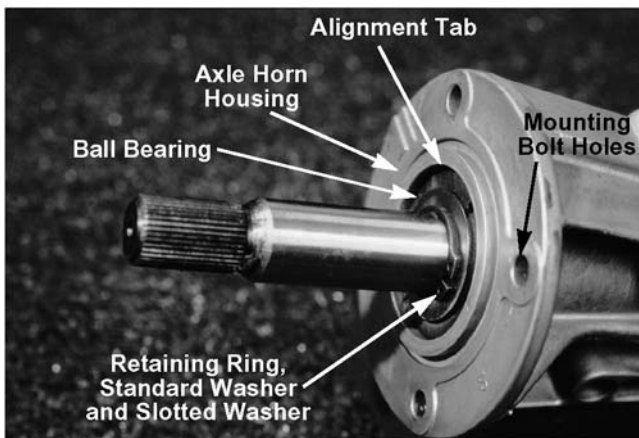


Figure 5-9.

11. Shown here is the feeler gauge inserted between the brake disc and outer brake puck. To set the brake you will have to remove the cotter pin from the brake bolt, and then tighten or loosen the brake nut until the specified setting is reached. See Figure 5-10.

12. Once the brake is disassembled inspect the components for excessive wear or damage:

- A. Brake puck.
- B. Brake disc.
- C. Hi pro key.
- D. Brake puck plate.
- E. Brake yoke.
- F. Brake bracket.
- G. Two brake pins.
- H. Brake actuating arm.
- I. Washer.
- J. Brake nut and cotter pin.
- K. Brake bolts.
- L. Washer and spacer.

**➔ NOTE**

Bluing of the brake disc is caused by excessive heat in the brake assembly. This defect may be caused by binding vehicle brake linkage, or improper brake setting.

13. Removal and inspection for the right hand axle horn assembly is the same as the left hand axle horn. See Figure 5-11.

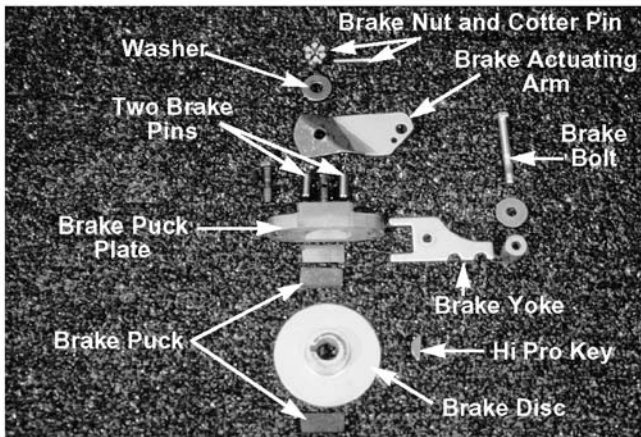


Figure 5-11.

14. Remove and inspect for the right hand axle housing assembly. The areas of concern are:

- A. Axle housing.
  - a. Seal areas.
- B. Axle shaft bearing.
- C. Final drive pinion shaft bearing.
- D. Reduction gear shaft bearing.
- E. Brake assembly shaft bearing. See Figure 5-12.

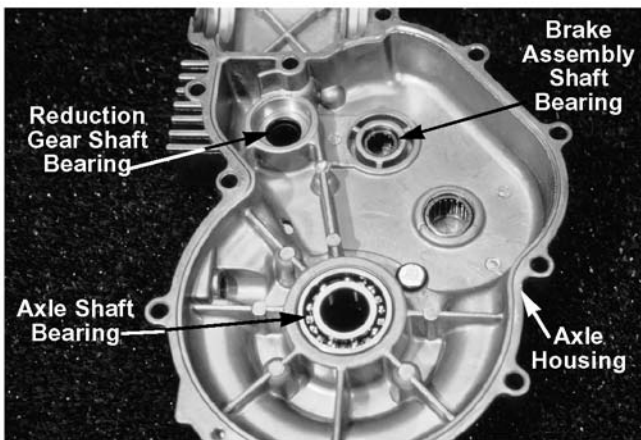


Figure 5-12.

15. Inspect the components remaining in the left hand axle housing assembly for excessive wear or damage:

- A. Axle housing.
- B. Differential assembly.

- C. Final drive pinion assembly.
- D. Reduction gear assembly.
- E. Brake shaft assembly.
- F. Input shaft assembly. See Figure 5-13.

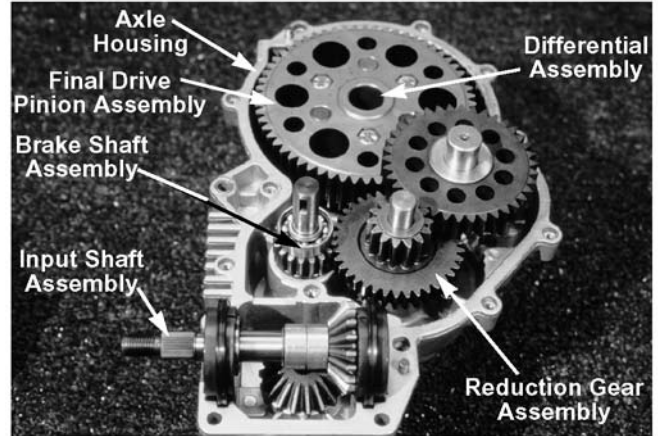


Figure 5-13.

16. Next we can identify the external components of the transmission:

- A. Output shaft.
- B. Input shaft.
- C. Charge pump assembly.
- D. Trunnion shaft (control shaft).
- E. Bypass valve.
- F. Housing screws. See Figure 5-14.

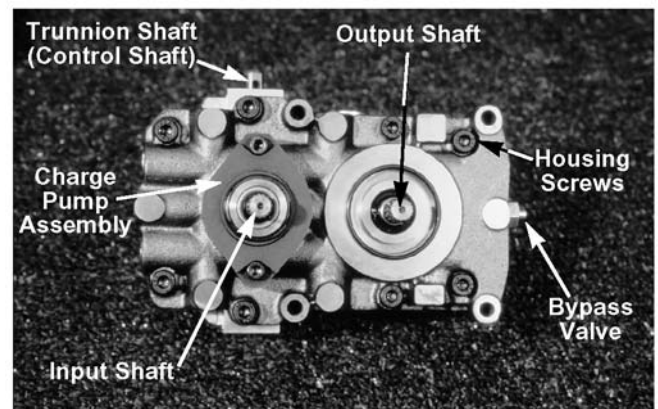
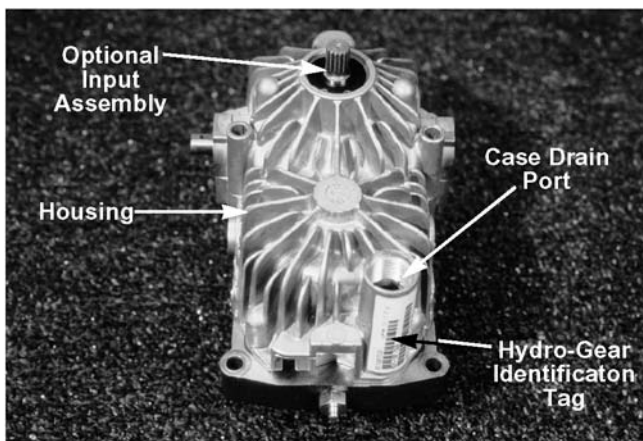


Figure 5-14.

17. Here we continue to identify the external components:

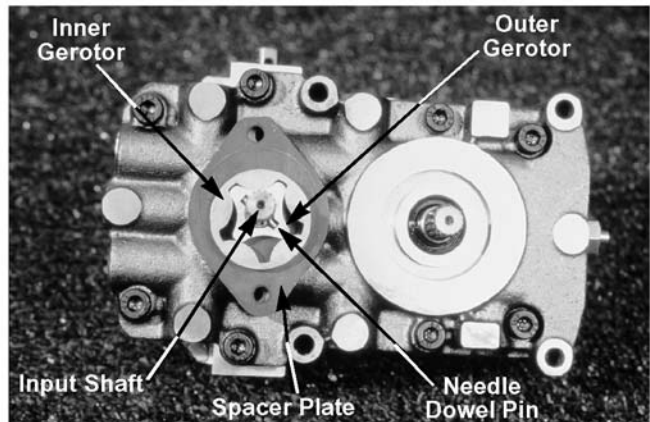
- A. Case drain port.
- B. Optional input assembly.
- C. Housing.
- D. Shown here is Hydro-Gear's identification tag for the transmission. It provides the following essential information:
  - a. Customer model number.
  - b. Hydro-Gear model number (starts on serial date "6275" (10 Oct. 96)).
  - c. Serial number. See Figure 5-15.



**Figure 5-15.**

18. After removal of the charge pump cover we can identify the charge pump assembly components:

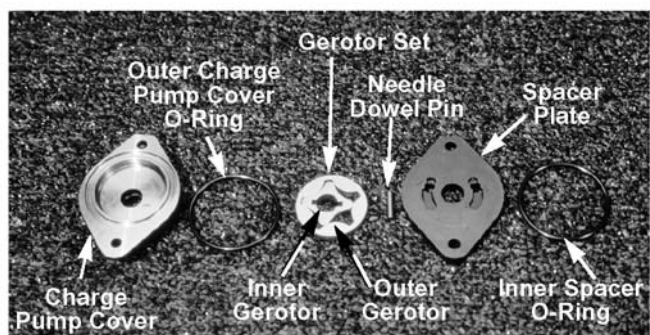
- A. Gerotor set.
  - a. Inner gerotor.
  - b. Outer gerotor.
- B. Input shaft.
- C. Needle dowel pin.
- D. Spacer plate. See Figure 5-16.



**Figure 5-16.**

19. Here we can inspect the removed components of the charge pump assembly for excessive wear or damage:

- A. Inner spacer o-ring.
- B. Spacer plate.
- C. Needle dowel pin.
- D. Gerotor set.
  - a. Inner gerotor.
  - b. Outer gerotor.
- E. Outer charge pump cover o-ring.
- F. Charge pump cover. See Figure 5-17.



**Figure 5-17.**

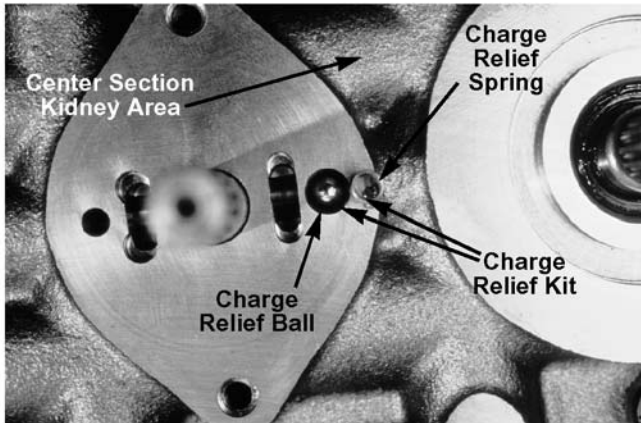
20. Now that we have removed the charge pump assembly components down to the spacer plate we can identify and inspect the remaining parts and center section kidney area:

- A. Charge relief kit.

- a. Charge relief spring.
- b. Charge relief ball.

B. Center section kidney area.

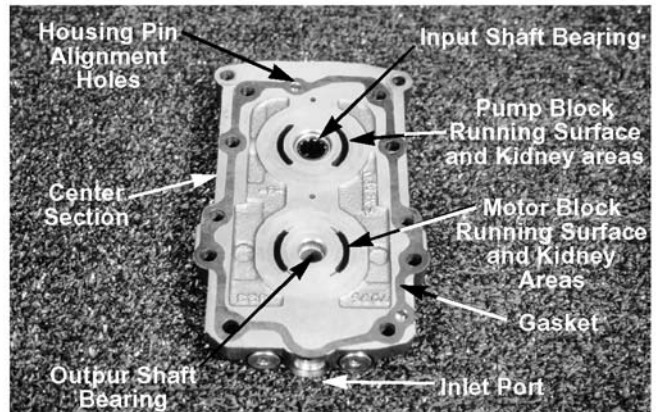
21. Removal of the housing screws will allow the disassembly of the center section from the housing. See Figure 5-18.



**Figure 5-18.**

22. Here we can identify center section components and inspect for wear or damage:

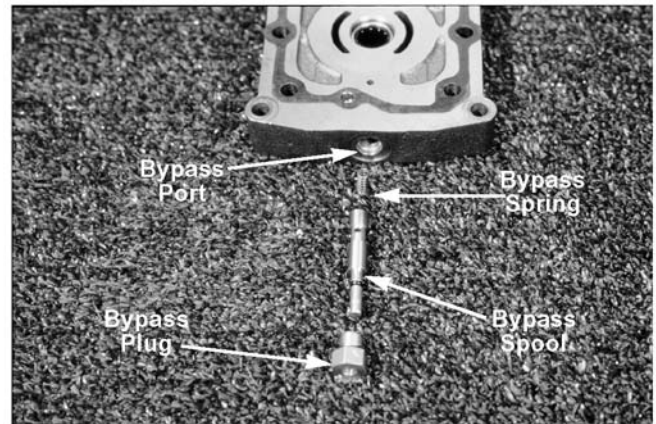
- A. Center section.
- B. Inlet port.
- C. Gasket (always replace).
- D. Pump block running surface and kidney areas.
- E. Motor block running surface and kidney areas.
- F. Input shaft bearing.
- G. Output shaft bearing.
- H. Housing pin alignment holes. See Figure 5-19.



**Figure 5-19.**

23. Here we have removed the bypass valve assembly for identification and inspection:

- A. Bypass plug.
- B. Bypass spool.
- C. Bypass spring.
- D. Bypass port. See Figure 5-20.



**Figure 5-20.**

24. And here we have removed the check valve assembly for identification and inspection:

- A. Check plug.
- B. Check spring.
- C. Poppet (may have a ball check).
- D. Check valve port. See Figure 5-21.



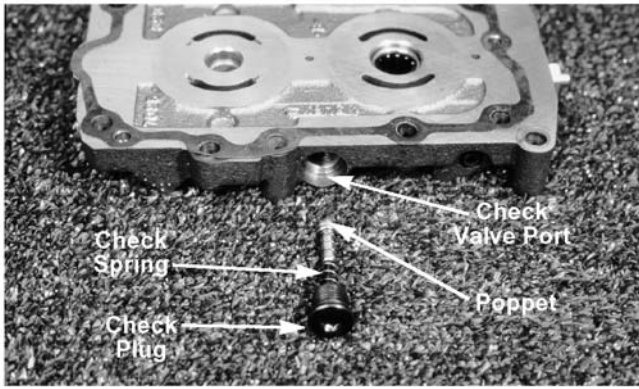


Figure 5-21.

25. Shown here for identification are the remaining components in the housing, after the center section is removed.

- A. Fixed motor block assembly.
- B. Pump block assembly.
- C. Input shaft.
- D. Housing alignment pins. See Figure 5-22.

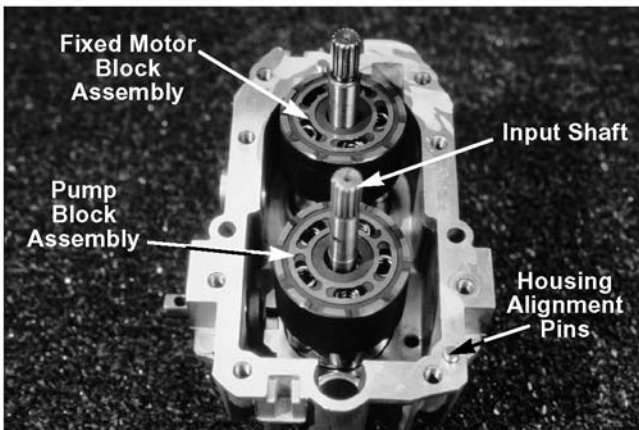


Figure 5-22.

26. Here is the motor block assembly removed and ready for inspection:

- A. Pistons.
- B. Piston seat.
- C. Piston spring.
- D. Motor block assembly.
- E. Motor shaft (splines).

Inspect the motor block, piston seat areas, running surface, and splines for excessive wear or damage. See Figure 5-23.

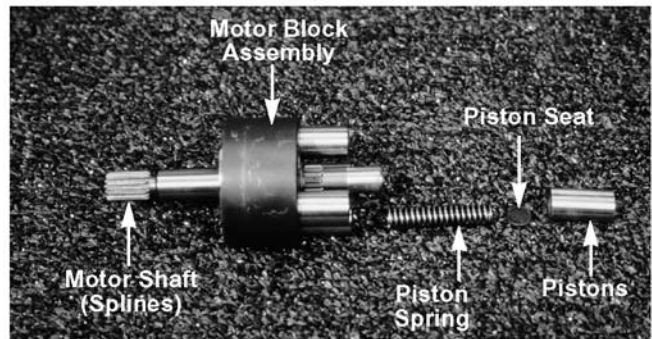


Figure 5-23.

27. Now we can identify the remaining components in the housing assembly:

- A. Swashplate.
- B. Trunnion shaft.
- C. Fixed thrust bearing assembly.
- D. Input shaft.
- E. Pump block spring and thrust washer. See Figure 5-24.

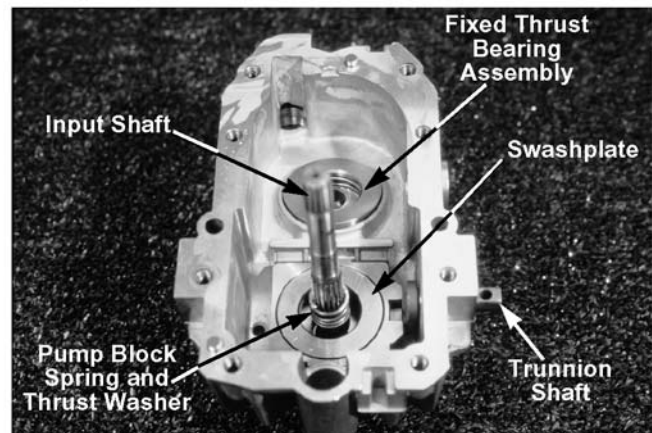
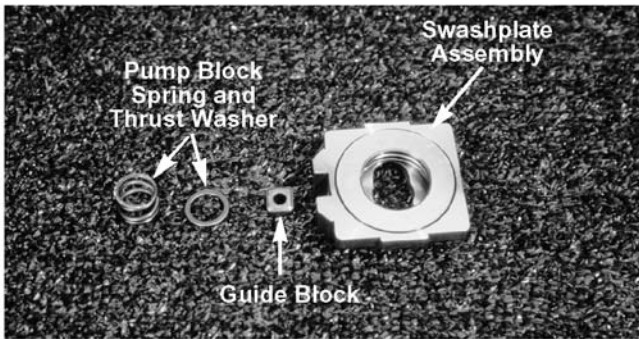


Figure 5-24.

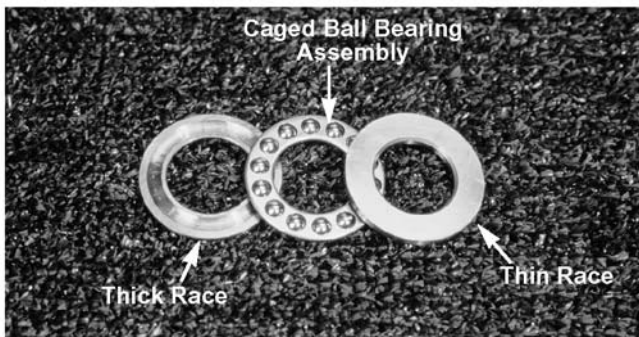
28. After the swashplate assembly is removed from the housing inspect all parts for excessive wear or damage.

- A. Pump block spring and thrust washer.
- B. Guide block.
- C. Swashplate assembly. See Figure 5-25.



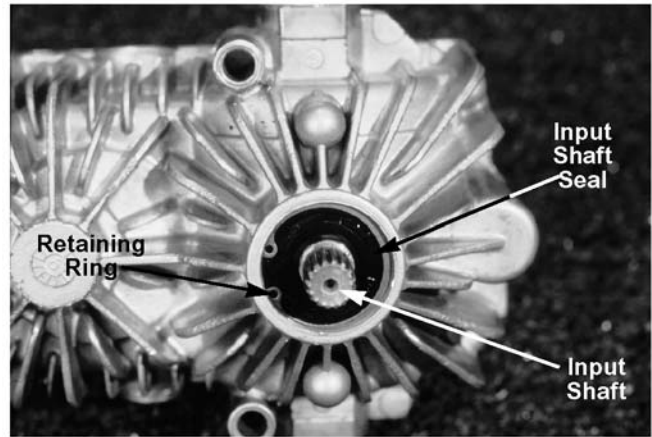
**Figure 5-25.**

29. After removal of the thrust bearing from the swashplate inspect it for excessive wear or damage.
  - A. Thick race (always mates to the rotating group).
  - B. Caged ball bearing assembly.
  - C. Thin race (never mates to the rotating group). See Figure 5-26.



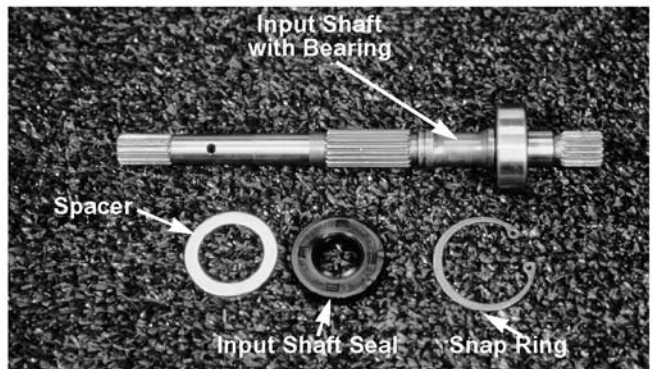
**Figure 5-26.**

30. Here on the external side of the housing we can identify:
  - A. Input shaft.
  - B. Input shaft seal.
  - C. Retaining ring. See Figure 5-27.



**Figure 5-27.**

31. Once the input assembly is removed, disassemble and inspect each part for excessive wear or damage.
  - A. Input shaft with bearing
  - B. Snap ring
  - C. Input shaft seal (always replace with a new seal)
  - D. Spacer. See Figure 5-28.



**Figure 5-28.**

# TRANSAXLES

## 6-1. GENERAL.

6-1.1 The single speed transaxle combines transmission and differential in one sturdy unit to eliminate chain drive and its problems. The

disc brake is part of the transaxle for more effective, easier braking and protection from contamination by oil, grease, dirt and water. See Figure 6-1.

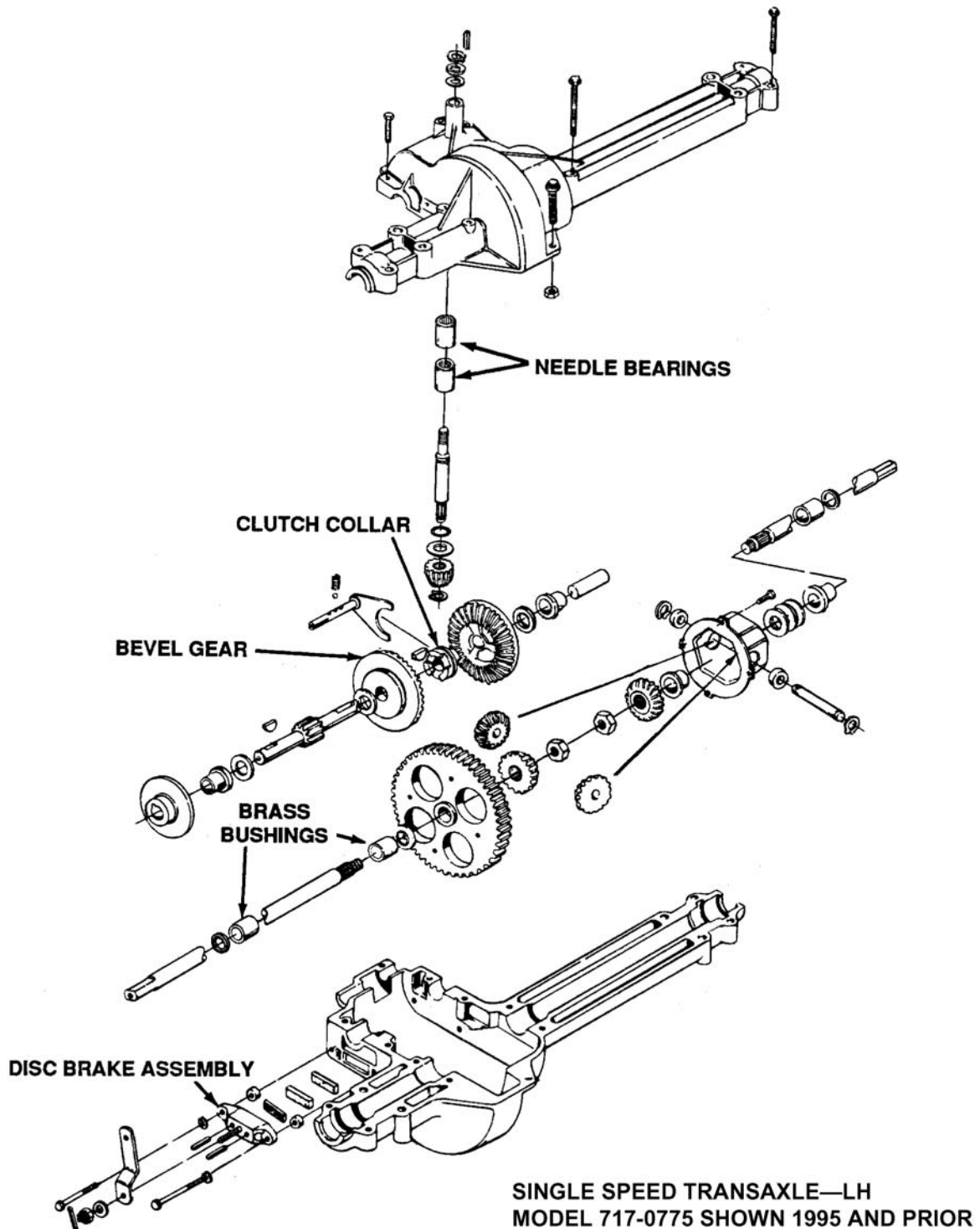


Figure 6-1. Single Speed Transaxle



**New for 1996**  
 The differential assembly is now sold as a complete unit and is not serviceable. An engineering change was made at the factory. The differential assembly screws are now pinged. This eliminates screws backing out of the bull gear and differential can.

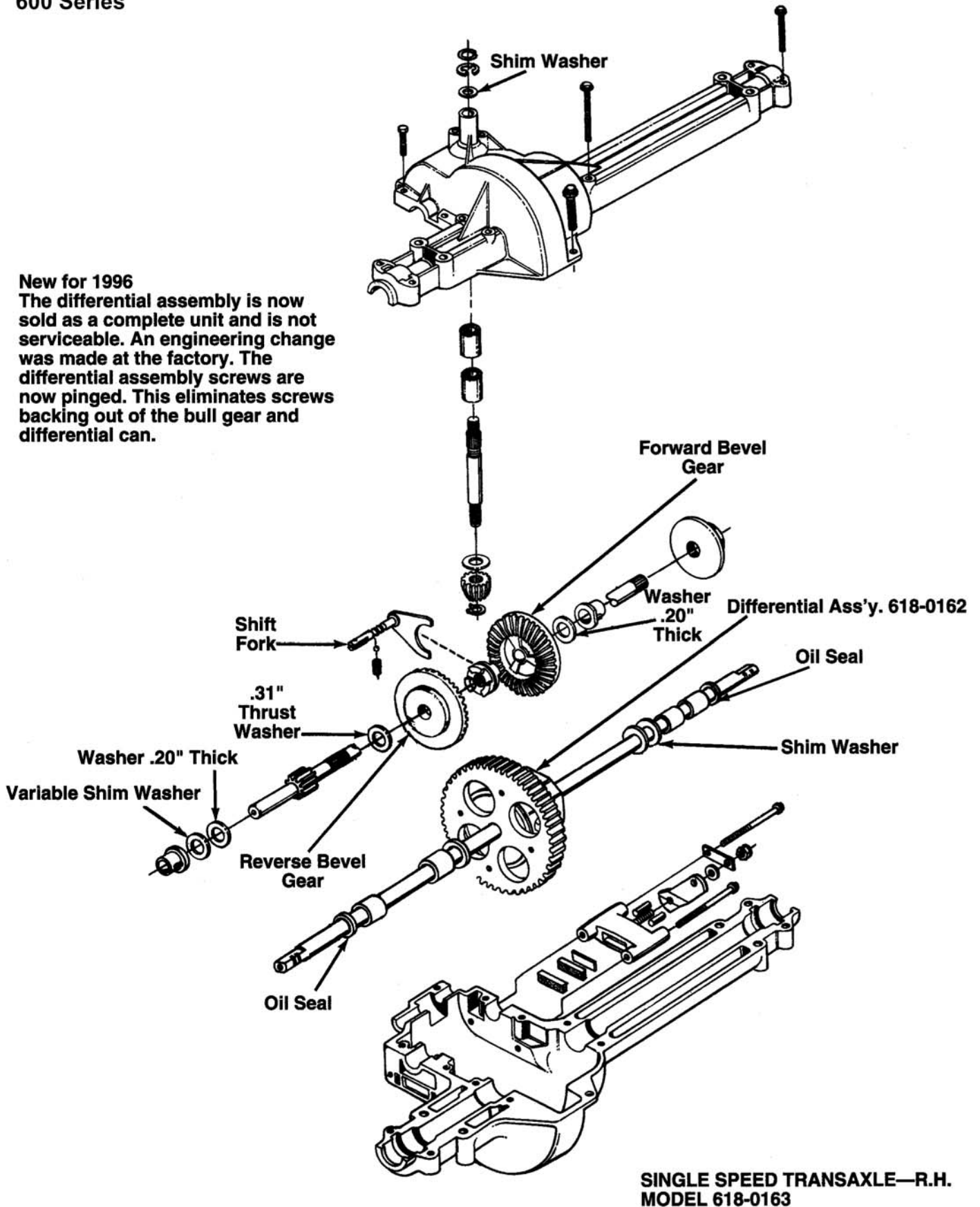


Figure 6-2. Single Speed Transaxle—R.H.

6-1.2 Also featured are high speed needle bearings on the input shaft and four brass bushings which provide added support for the axles. Clutch collar and bevel gears have three paws for easier shifting and less backlash.

6-1.3 The transaxle is lubricated and sealed at the factory, and does not require checking. If disassembled for any reason, lubricate with 10 ounces of Shell Durina Grease, part number 737-0148.

6-1.4 Basically all single speed transaxles are the same. There were some changes in 1991 and 1992 to improve the performance and durability.

6-1.5 The purpose of this notice is to provide the owner of a lawn tractor with information which may enable him to get the most efficient and satisfactory services from his mowing equipment. Note the following:

1. Some rules must be followed to secure the maximum service life from this unit. The shift lever should never be forced. Shifting should be done slowly. The clutch pedal should be fully depressed each time the mower is changed from reverse to forward or forward to reverse. Shifting from forward to reverse must never be done without declutching. If the unit will not go into gear, the clutch pedal should again be fully depressed and the shift lever slowly moved to the desired position. After the shift lever has been moved to the desired position, it must not be held there forcefully. The results of disregarding these rules can mean an inoperative transmission, sometimes in less than half an hour.
2. Abusive use can cause the yoke of the detent shaft to bend. This bent part, riding inside the clutch collar and rubbing the sides of the center groove, builds up excessive heat, scores the clutch collar and builds up metal on the yoke. When enough metal is built up on this yoke, one of several things occurs. The built-up metal seizes the clutch, and the transmission apparently freezes up. The built-up metal seizes the clutch collar and snaps the detent shaft assembly where the yoke is swaged in place. The built-up metal expands so rapidly that the clutch collar is split into two parts. If the yoke is bent on one movement of the lever, on the next movement it may seize so rapidly the detent shaft assembly will snap. This can occur with no metal build-up. In all cases, the scored

clutch collar, the built-up metal on the yoke and a bent yoke indicate abusive use.

3. Often it is noted that the transmission will not remain in forward position. This is again the result of abuse rather than use. Operating without proper declutching wears away the inner part of the large bevel gear and because a large radius assumes the place of the necessary flat surface there, the clutch collar tends to slip back out of position. The condition occurs most often on the forward gear because it is used most often.
4. When repairs are necessary to correct the result of improper operation, it should be noted that the transmission contains 10 ounces of Shell Durina Grease, part number 737-0148. We suggest it or an equivalent when repairs are made in the field.
5. Transmissions operated in the proper manner will give a maximum of service with a minimum of maintenance. The manner of operation determines the life of the unit.

## **6-2. TRANSAXLE CHANGES FOR 1990, 1991, 1992 AND 1997 MODELS.**

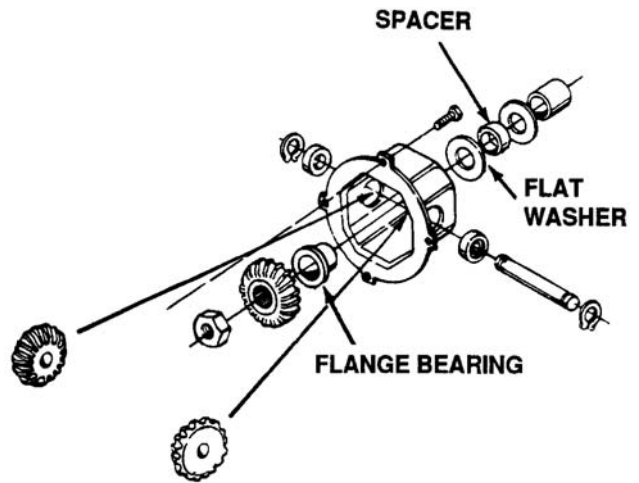
6-2.1 1990 changes were as follows:

1. In 1989 MTD used the single speed transaxle 717-1050. In 1990 the transaxle axle length was changed by 1/2 inch on each side. Older model transaxles will not fit on the 1990 600 Series tractors. The new transaxle is a 717-0542.
2. The 1990 transaxle part numbers are as follows:
  - a. 300 series—717-0775
  - b. 400 series—717-1237
  - c. 500 series—717-0775V
  - d. 600 series—717-0542

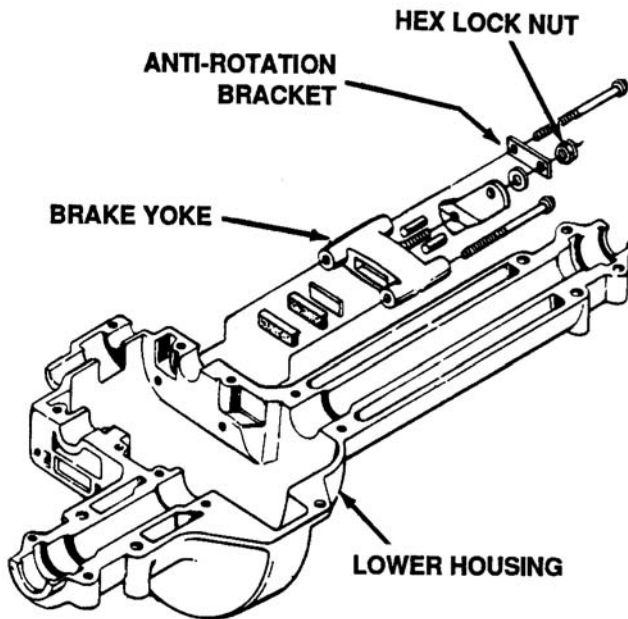
6-2.2 1991 changes were as follows:

1. The material used for the brake yoke prior to 1991 was powder metal. This has been changed to cast aluminum. Also, the brake adjustment castle nut and cotter pin have been changed to a hex lock nut and anti-rotation bracket. See Figure 6-3.

2. Prior to 1991 production, the brake mounting holes in the transaxle housing were tapped and used a standard hex bolt. This was changed for 1991 production, which uses self-tapping screws to secure the brake to the lower housing.
3. The 1997 transaxle part numbers are as follows:
  - a. 400 – 618-0166A
  - b. 500 – 618-0164A
  - c. 600 – 618-0163A
  - d. 600HD 4 w/steer – 618-0034

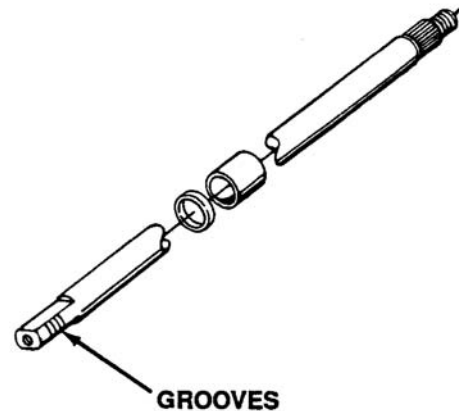


**Figure 6-4. Differential Housing Assembly**



**Figure 6-3. Brake and Lower Housing**

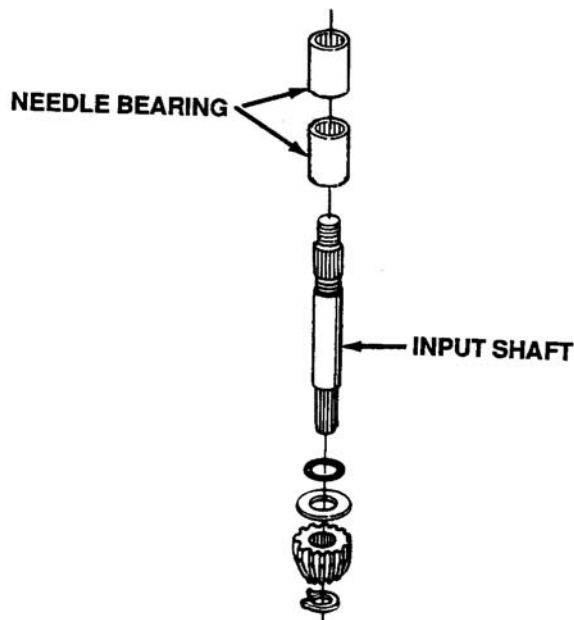
5. For 1991 production, grooves were put on or left off the axle ends for axle and transaxle identification. See Figure 6-5.



**Figure 6-5. Axle Identification**

4. The material used prior to 1991 was low carbon steel and has been changed to high strength low alloy steel. The embossing was removed and a spacer and flat washer installed for proper axle and housing equipment. Also, the bronze bearing used in the differential housing assembly has been changed to an iron flange bearing. See Figure 6-4.

6. Axles are identified as follows:
  - a. 300/500 series—no grooves
  - b. 400 series—2 grooves
  - c. 600 series—4 grooves
7. 1991 model transaxles ONLY. Prior to 1991, a keyed input shaft was used. This has been changed to a splined input shaft for 1991 production. The input shafts are NOT interchangeable unless the input shaft pulley is changed. See Figure 6-6.



**Figure 6-6. Splined Input Shaft**

8. Pulley changes for retrofits are as follows:
  - a. 600 series pulleys relate to tire size.  
20-inch tire—splined pulley—756-0581  
18-inch tire—splined pulley—756-0582
  - b. 500 series does not go by tire sizes.  
Splined pulley—756-0579
  - c. 300, 400 series.  
Splined pulley—756-0580
9. List of 1991 model transaxles:
  - a. 600 series—618-0002A—with the new brake assembly
  - b. 300-500 series—618-0025—without brake assembly
  - c. 400 series—618-0024A with the new brake assembly

**6-2.3 1992 changes were as follows:**

1. Prior to 1992 the drive shaft was a 10-tooth design. For 1992 it was changed to an 8-tooth design having 40% less tooth stress. These broached teeth improve surface finish and repeatability. This adds superior strength to this area.

2. Prior to 1992, the clutch collar was keyed onto the drive shaft. For 1992, it was changed to a splined drive shaft. The parts were tested up to 575 ft-lbs.
3. Prior to 1992, the brake disc was keyed into the drive shaft. For 1992, broached splines were used.
4. Prior to 1992 the differential gear had 72 teeth. For 1992 58 teeth were used with a 40% stronger tooth form. The flange bearing was also removed from the differential gear. New differential can bearings are being used. The double D design is replaced by a staked spline bearing.
5. Prior to 1992, the shift shaft was 3/8 inch diameter. For 1992 production, this changed to 1/2 inch diameter. Turned cylindrical detent grooves replaced milled partial grooves eliminating possible misaligned detent balls.
6. Two anti-rotation bracket mounting holes were added to the front of the upper housing. The change will reinforce the mounting of the transaxle to the rider. (Also a larger groove has been incorporated to accommodate shaft previously mentioned.) The detent ball and spring can now be assembled in either the upper or lower new housings.

**➔ NOTE**

For complete and accurate tolerances, electronic gaging/shimming has been implemented.

7. The following transaxle kits are available:

CURRENT TRANSAXLE		KIT NUMBER
717-1050	use	753-0539
717-0542	use	753-0536
618-0002	use	753-0556
717-1237	use	753-0558
618-0024	use	753-0557

**6-3. DISASSEMBLY/ASSEMBLY OF TRANSAXLE.**

**6-3.1 Disassemble transaxle as follows:**

**➔ NOTE**

Due to model variations of units, these instructions are intended for service repairs after the transmission has been removed from the unit.

1. Remove the shift lever support bracket from the transaxle, by removing one self-tapping screw on top of transaxle and two hex bolts on side of transaxle at brake. See Figure 6-7.

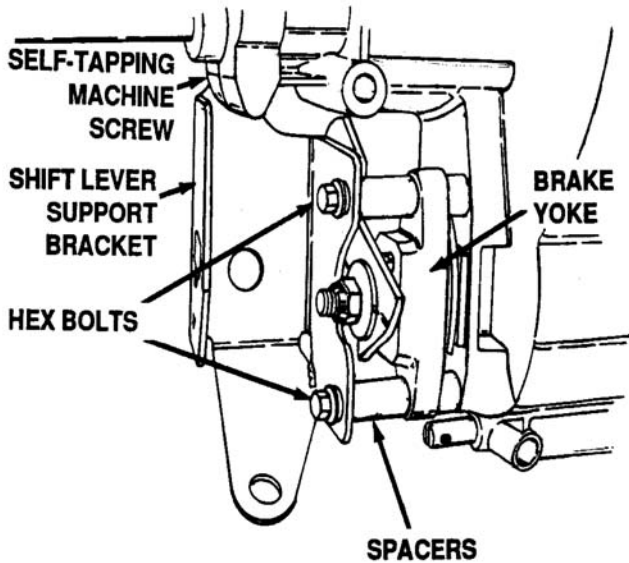


Figure 6-7. Shift Lever Support Bracket



The brake yoke, two spacers and brake puck will drop out of transaxle housing at this time.

2. Remove the brake disc from the drive shaft by simply sliding it off shaft. See Figure 6-8.

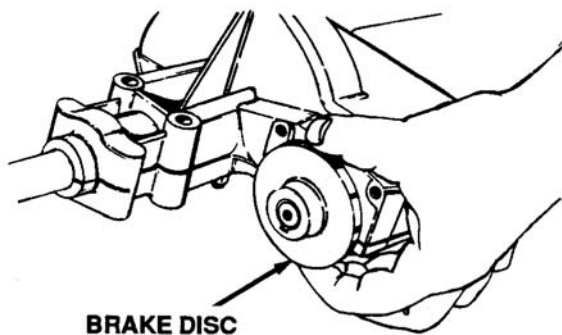


Figure 6-8. Removing Brake Disc

3. Remove four 1/4-20 x 1.75 inch long bolts from housing (located at the center of transaxle). Remove four 1/4-20 x 1.25 inch long bolts from housing (2 located at each end of the transaxle). See Figure 6-9.

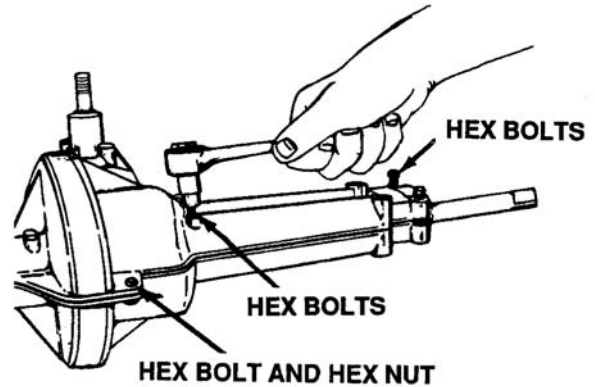


Figure 6-9. Location of Hex Bolts

4. Remove one hex bolt 1/4-20 x .88 inch long and hex nut 1/4-20 thread at rear of transaxle housing.
5. Remove one hex bolt 1/4-20 x 1.00 inch long from front of transaxle housing.
6. Remove the snap ring from input shaft using a pair of snap ring pliers. See Figure 6-10.

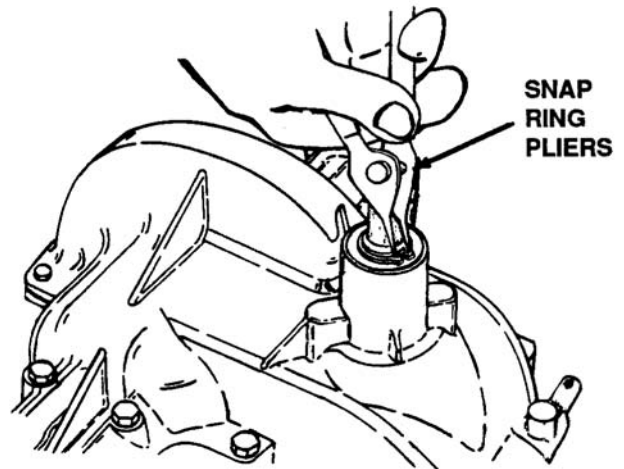


Figure 6-10. Removing Snap Ring

- Lift off the top transaxle housing. See Figure 6-11.

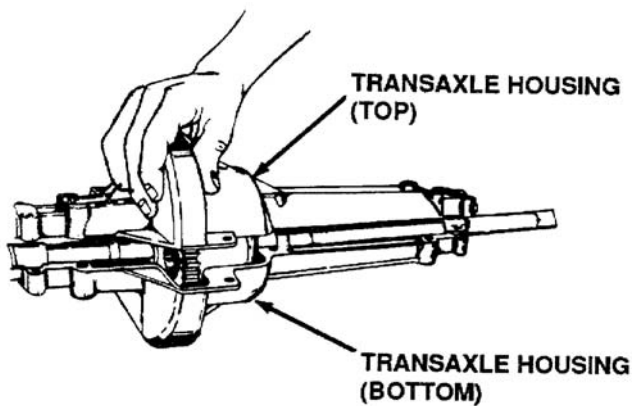


Figure 6-11. Removing Top Transaxle Housing

**NOTE**

There are 10 ounces of grease in this transaxle.

- As you disassemble the rest of the transaxle you will want to wash each part with a solvent to clean and inspect for wear or damage.
- Pack transaxle with grease when reassembling. See Figure 6-12.

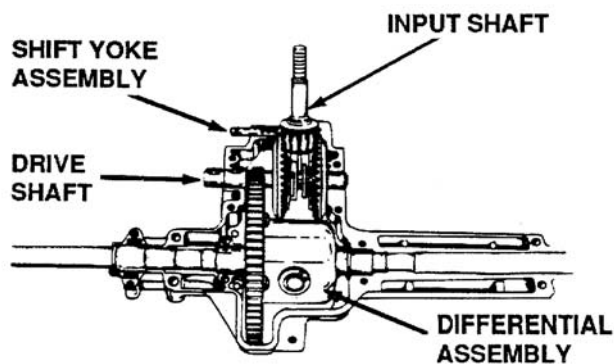


Figure 6-12. Internal Parts of Transaxle

- Lift the input shaft out first and with a pair of snap ring pliers, remove the snap ring on the end of input shaft. See Figure 6-13.

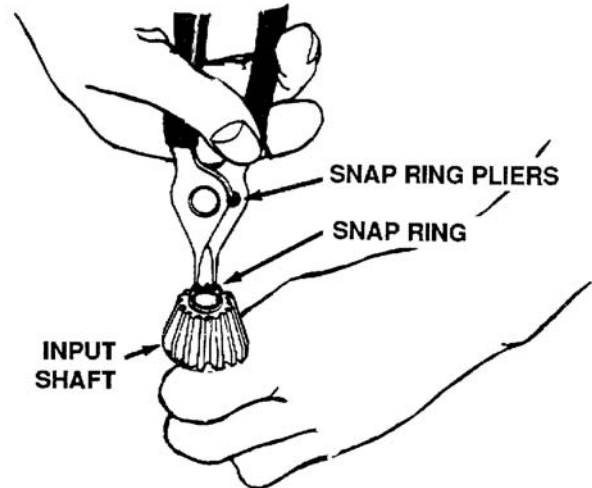


Figure 6-13. Removing Snap Ring

- Disassemble the input shaft and inspect parts. See Figure 6-14.
- Lift the drive shaft and shift yoke assembly out of housing. See Figure 6-15.

**NOTE**

Upon sliding the shaft yoke assembly out of the housing, the detent ball and spring will pop out. Take care to not to lose them. Also, note the cylindrical grooves on the shift fork assembly. The detent ball and spring can now be assembled in either the upper or lower housings.

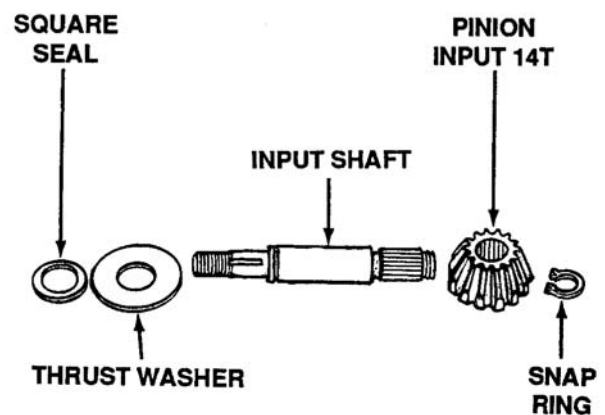


Figure 6-14. Disassembled Input Shaft

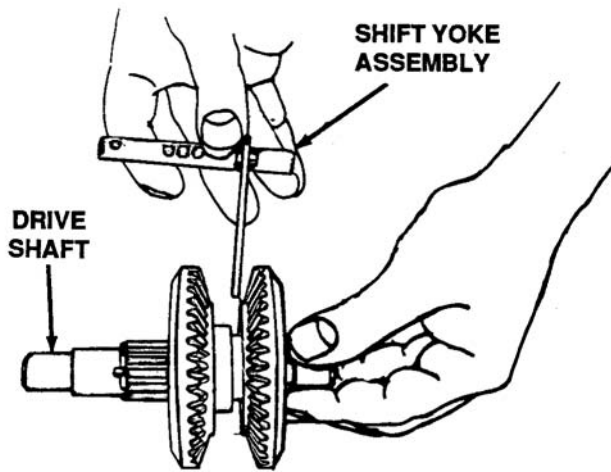
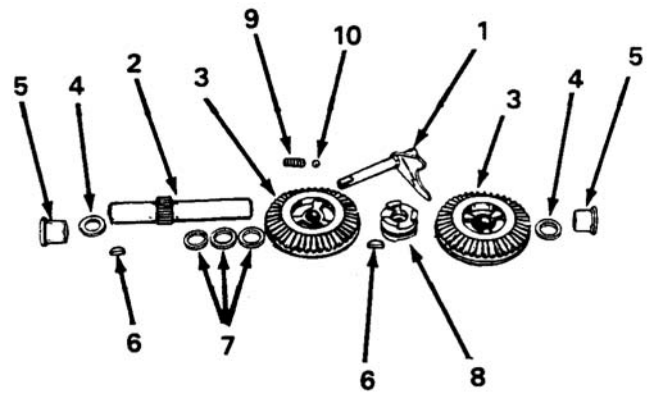


Figure 6-15. Drive Shaft and Shift Yoke Assembly

13. Disassemble drive shaft and inspect parts. See Figure 6-16.
14. Lift out the differential assembly and two axles. See Figure 6-17.

**NOTE**

There is now a new differential housing assembly. The old style housing assembly, part number 717-0777, will be crossed over to kit number 753-0546. This kit includes differential housing, part number 717-1252 and shims, part number 736-0351.



1. Shift Yoke Assembly
2. Drive Shaft
3. Bevel Gear 12T
4. Shim Washers
5. Flange Bearing
6. Woodruff and Hi-Pro Keys
7. Shim Washers
8. Clutch Collar
9. Detent Spring
10. Detent Ball

Figure 6-16. Drive Shaft

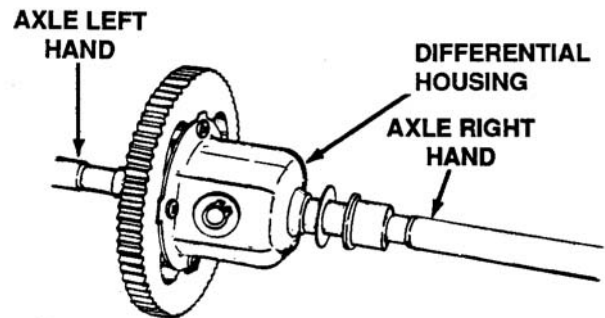


Figure 6-17. Differential Housing and Axles

**NOTE:** 1996 to present the differential assembly will be sold as a complete unit.

15. With a phillips or torx screwdriver (depending on the year) remove the four screws holding the differential gear to the differential housing. See Figure 6-18.

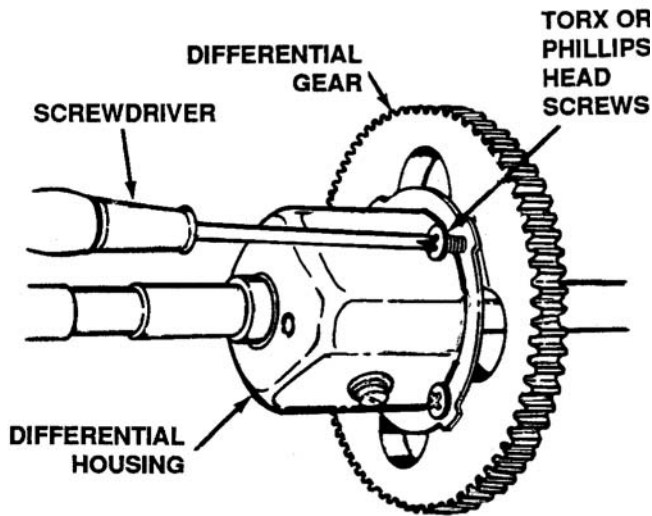


Figure 6-18. Differential Gear and Housing

**NOTE**

Differential gears prior to 1992 had 72 teeth. In 1992 58 teeth were used which made them 40% stronger.

16. Separate the differential gear from differential housing. See Figure 6-19.

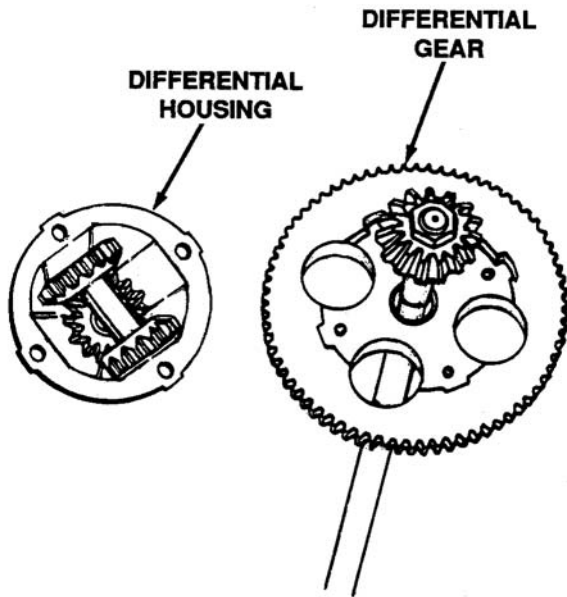


Figure 6-19. Separating Differential Housing and Gear

17. Remove oil seal, flat washer and two sleeve bearings from left hand axle. See Figure 6-20.

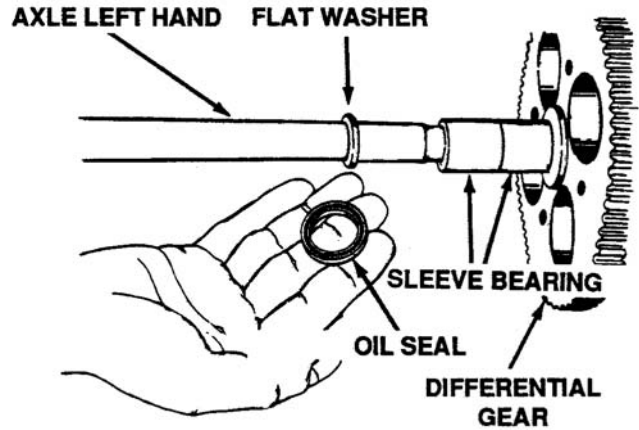


Figure 6-20. Removing Oil Seal

**NOTE**

When reassembling the left-hand axle, the open end of the oil seal faces out to keep dirt from entering the transaxle. You may find some seepage from the transaxle at the seal but a small amount is acceptable.

18. Inspect differential gear, 58 or 72 teeth, for wear or damage. Remove and replace if necessary.
19. To complete disassembly of differential, remove the snap ring on one end of cross shaft; this will allow you to remove the miter gears on cross shaft. See Figures 6-21 and 6-22.

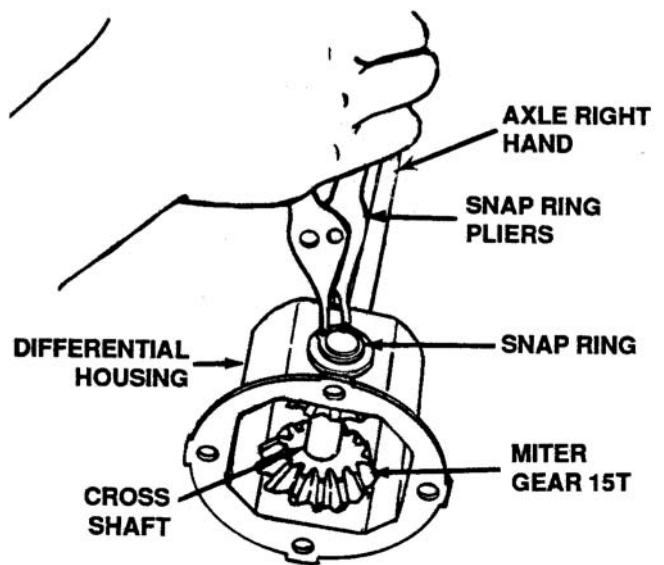
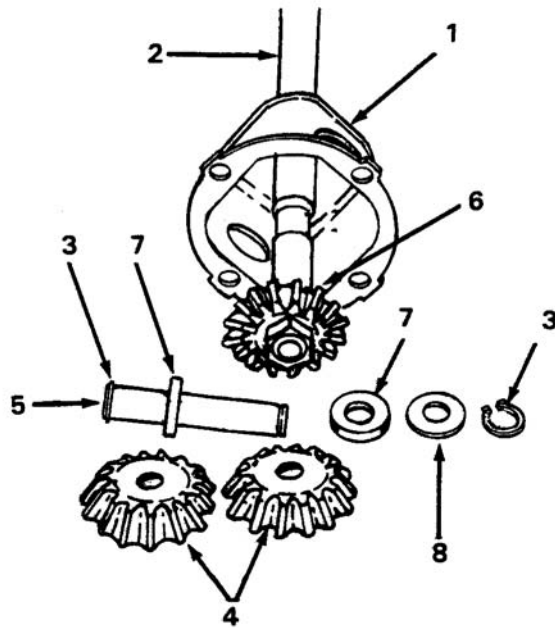


Figure 6-21. Disassembling Differential Housing





1. Differential Housing
2. Axle Right Hand
3. Snap Ring
4. Miter Gear 15T
5. Cross Shaft
6. Miter Gear 15T Splined
7. Thrust Bearing
8. Flat Washer

Figure 6-22. Differential Housing

20. Remove hex lock nuts on end of each axle to remove the miter (splined) gear. See Figure 6-23.

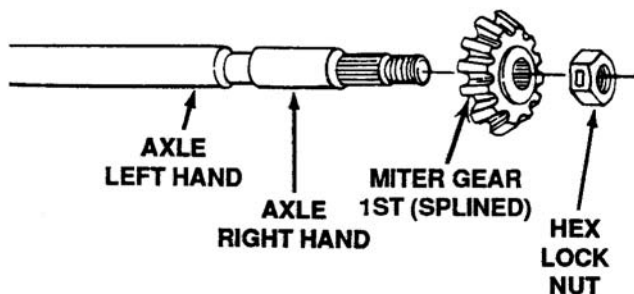


Figure 6-23. Removing Lock Nuts From Ends of Axles

➡ NOTE

Axles and miter gears were changed in 1986. Because of that change, 1985 and prior production units must use kit 753-0429 for repair.

This kit will include 2 axles and four miter gears. If a customer has a 1985 and prior production unit and needs only the miter gear that fits on the end of the axles, you can order the smaller ID miter gear 717-0687 instead of the complete kit. Many of the gears in these transaxles are made of powdered metal with minimum of 75,000 PSI strength. They are also heat treated and oil impregnated.

➡ NOTE

Beginning in 1989-1990 production, the axle shaft no longer has a notch. The notch allowed the shaft to break before any internal damage resulted; however, there have been no warranty failures to date. The axle shafts are also heat treated and tested to 480 ft-lbs of torque.

6-3.2 Assemble transaxle in reverse order of steps 1 through 20 and as follows:

1. You MUST grease the drive shaft prior to putting on the bevel gears or a mechanical weld between the drive shaft assembly and bevel gear will occur.
2. Notice the tabs on the flange bearings that must be seated into the housing, if this assembly is taken apart.
3. Notice the shimming difference between this currently used transaxle versus the one used in 1991. There are fewer shims due to the electronic shimming and the tolerances held on transaxle housing during manufacturing.
4. When performing repairs on the transaxle it is important to have the proper amount of gear backlash to avoid gear failure and noise. Measure the backlash with the assembly upside down and the input shaft in the upper housing. Separate the bevel gears and measure between the bevel gears and input shaft with a feeler gauge or dial indicator. This backlash should be between .006 to .015 and can be adjusted by using a combination of shim washers.
  - a. Outer shim washers come in two thicknesses: .020, part number 736-0329 and .030, part number 736-0336. See Figure 6-16.
  - b. Inner shim washers have two combinations: 3 washers each measuring .040, part number 736-0337, or 1 washer measuring .030, part number 736-0336 and two washers measuring .040 each, part number 736-0337.

Models 760 thru 769 Riders

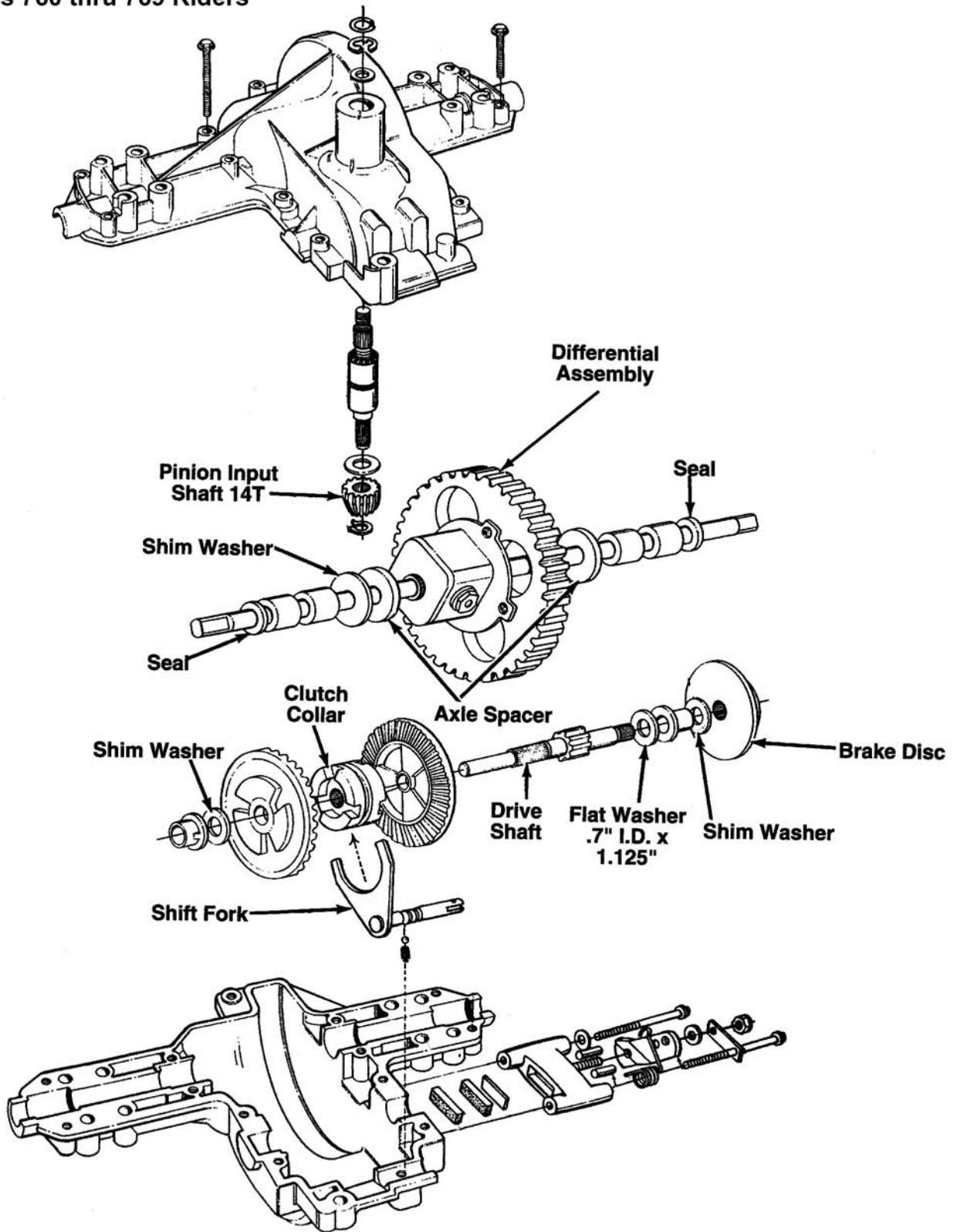


Figure 6-24. Single Speed Transaxle—L.H. Model 618-0167

The transaxle is lubricated at the factory and does not require checking. If disassembled for any reason, lubricate with 10 oz. of Shell grease, part number 737-0148.

## 6-4. HYDROSTATIC TRANSAXLE.

### 6-4.1 General.

1. The 717-0950 transaxle incorporates differential and gear reduction assemblies. See Figure 6-12. It must be used with part number 717-0940 BDU-10S-Sunstrand Hydrostatic Pump. (See Section 9.) All internal drive and axle shafts are resting/turning on heavy duty ball bearings designed for longer life expectancy. The input shaft has needle bearings and also incorporates a thrust bearing assembly for higher speeds with minimal wear. The housing is aluminum diecast and specially designed for use on lawn and garden tractors.

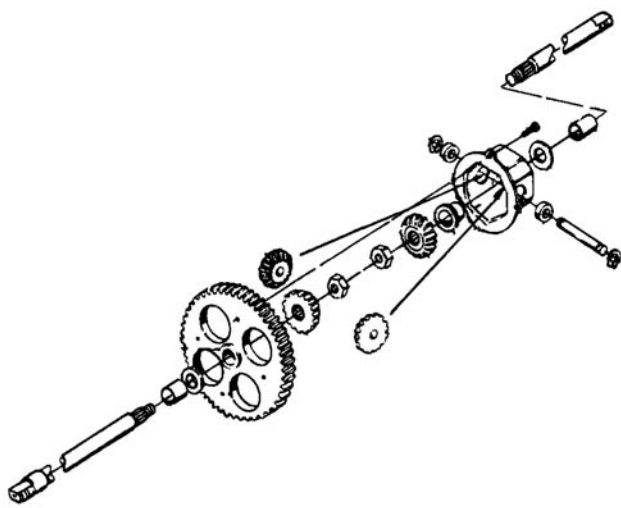


Figure 6-25. Differential Disassembly

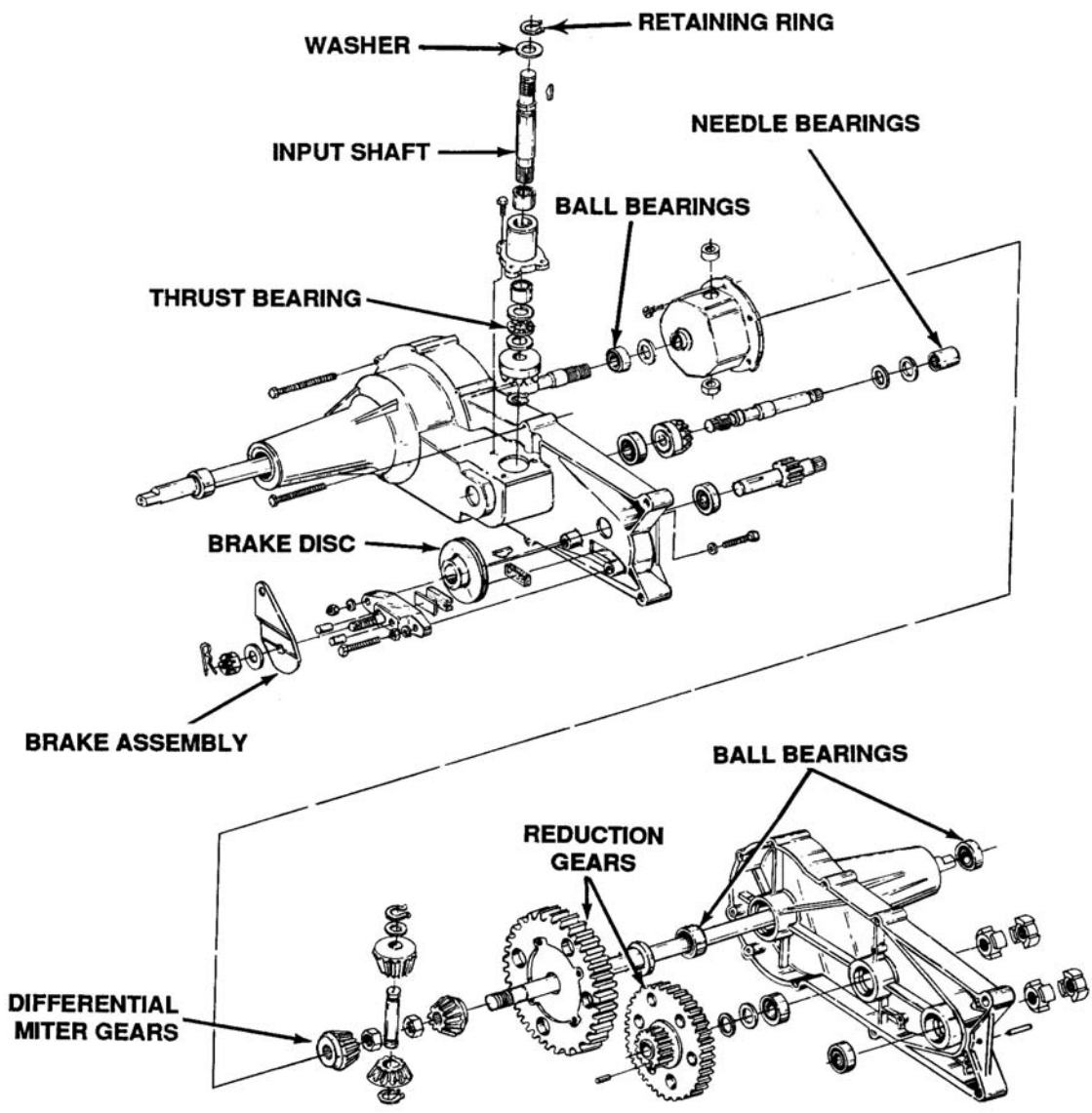


Figure 6-26. Hydrostatic Transaxle 717-0950

2. This heavy duty transmission guides the lawn and garden tractor smoothly forward no matter what type of ground is being covered without shifting or any clutching. A control lever is used to regulate the hydrostatic pump to increase or decrease the speed in either forward or reverse directions. The transaxle also houses the complete disc brake assembly with provision for easy adjustment.

**➡ NOTE**

The transaxle is lubricated and sealed at the factory. It does not require checking. If disassembled for any reason, lubricate with 16 oz. of Shell Durina #0 grease, part number 737-3047.

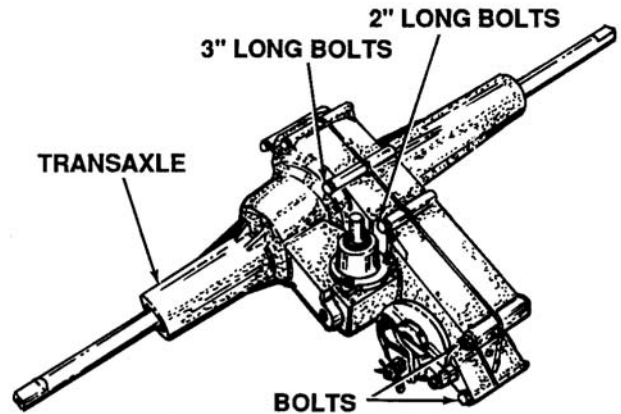


Figure 6-28. Pump Removal

#### 6-4.2 Disassembly of Transaxle.

1. Remove transaxle and pump from tractor. See Figure 6-27.

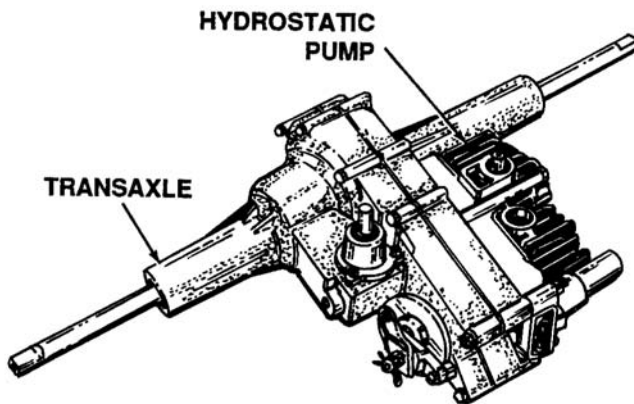


Figure 6-27. Transaxle and Pump

2. Remove pump from transaxle by removing two bolts and nuts from front of transaxle using a 1/2 inch wrench. See Figure 6-28.
3. Remove retaining ring from input shaft. See Figure 6-29.

**➡ NOTE**

The washer under the retaining ring is factory selected. If you are repairing the unit, the maximum end play is .010 and is adjusted with shim washers and checked with a feeler gauge under the retaining ring.

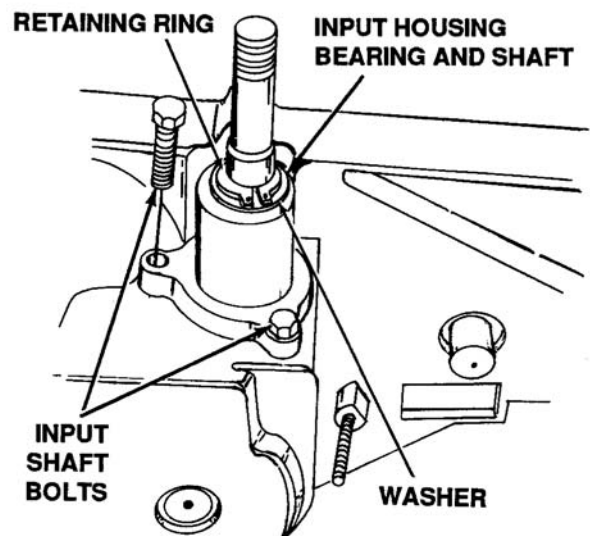


Figure 6-29. Input Housing Bearing and Shaft

4. You must remove the input housing bearing and shaft from the top of transaxle in order to remove all of the bolts holding the transaxle together.

**➡ NOTE**

Use an impact puller to remove the bearings from the housing or tap out using a rod of the correct diameter. Reinstall the bearings with Loctite Bearing adhesive sealant. Press in place using an arbor press and wipe bearing clean of excess Loctite.

- Remove three input shaft bolts.

**NOTE**

When reassembling use Loctite on input shaft bolts and torque to 80-120 in-lbs.

- Remove six bolts 3 inches long and two bolts 2 inches long from transaxle housing halves. A 3/8 inch wrench is required.

**NOTE**

Housing couplings may seize to shaft splines. Use a puller to remove or GENTLY tap them for removal.

- Remove disc brake and disc by removing a hex nut and lock washer on the rear of brake. Loosen hex nut on brake stop bolt. Remove the brake stop bolt, nut and lock washer. See Figure 6-30.

**NOTE**

When you remove the disc brake, the backup disc and one brake pad will fall out. Also when removing the disc the second brake disc will fall out.

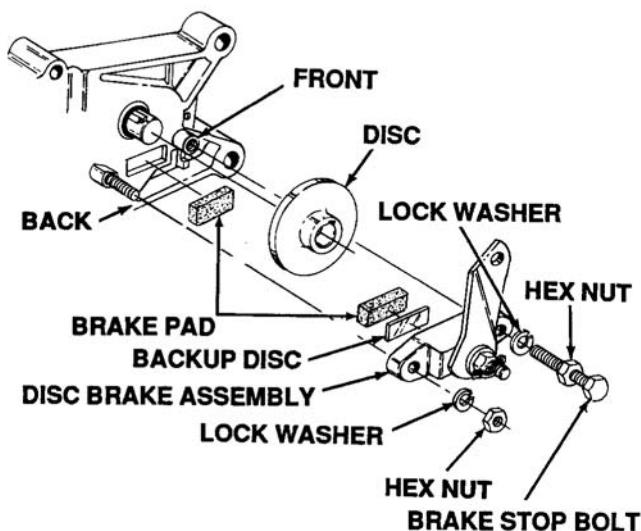


Figure 6-30. Disc Brake and Disc

**NOTE**

You do not have to remove the brake assembly to split housing halves. This is done only if you are going to remove the pinion shaft with the 11 tooth gear.

- Before pulling housing halves apart, axle shaft ends must be free of rust and nicks for ease of disassembly. With a piece of fine emery cloth clean shafts and inspect for good clean surfaces. See Figure 3-31.

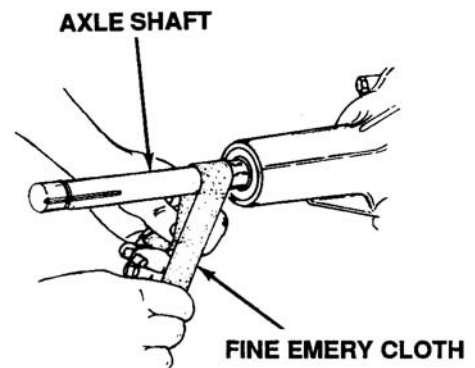


Figure 6-31. Cleaning Axle Shaft

- Carefully pry halves apart in areas shown in Figure 6-32.

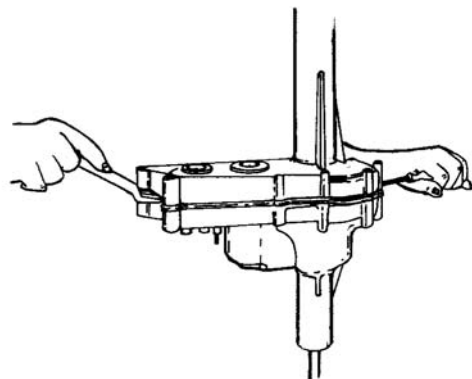


Figure 6-32. Prying Halves Apart



### CAUTION

DO NOT nick mating surfaces. Tap lightly on drive shaft with a brass hammer as needed. See Figure 6-33.

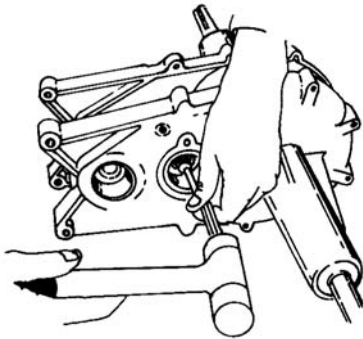


Figure 6-33. Separating Halves With Brass Hammer

10. After transaxle housing halves have been separated, clean all grease from parts. See Figure 6-34.

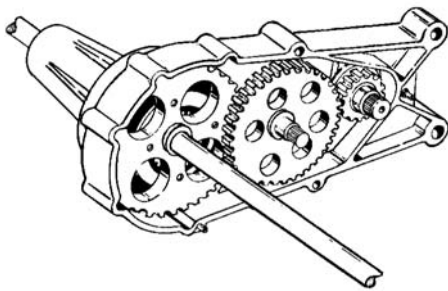


Figure 6-34. Clean Parts



### NOTE

When reinstalling screws into aluminum housings, you should turn the screws counter-clockwise until they click into place and seat themselves before tightening them in the usual manner. This will avoid cross threading and damage to the housing.

11. Remove reduction gear (60 and 17 tooth) from drive shaft. See Figure 6-35.



### NOTE

The washers between reduction gears and ball bearings are factory selected to insure proper

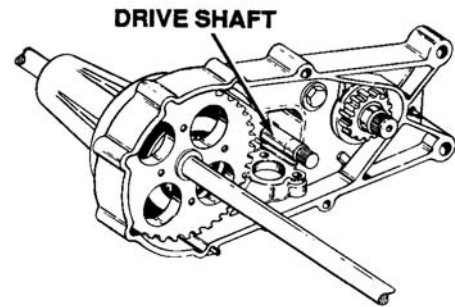


Figure 6-35. Reduction Gear Removal

clearance between the gears. A .040 shim washer is used on the small reduction gear side and either a .050 or .060 shim washer is used on the large gear side.

12. Inspect reduction gear for any damaged teeth. Also inspect needle bearing in the center of gear. Replace if necessary. See Figure 6-36.

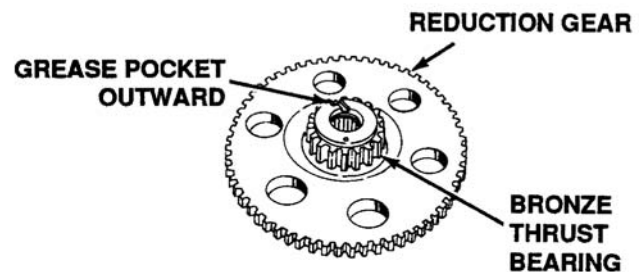


Figure 6-36. Reduction Gear Inspection and Replacement



### NOTE

The reduction gear also has a grease pocket. Upon reassembly, press bronze thrust bearing on reduction gear dowel pin. It is important that bronze thrust bearing grease pocket FACE OUTWARD as shown in Figure 6-36. The grease pocket is pressed on to reduction gear to insure grease movement. When replacing, make sure that it is installed properly. 14 oz. of Shell Durina #O grease is used in this transaxle.

13. Remove differential assembly from housing half. See Figure 6-37.

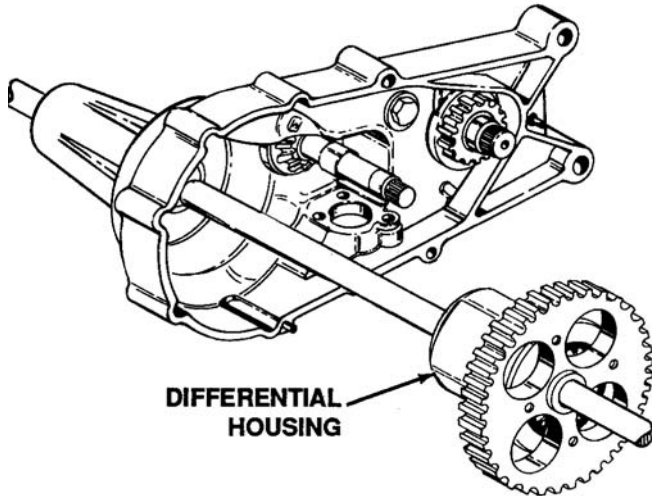


Figure 6-37. Differential Removal

14. Disassemble differential by removing four socket head bolts and lock washers. See Figure 6-37. Inspect differential gear (72 teeth) for any damage. Replace if necessary.

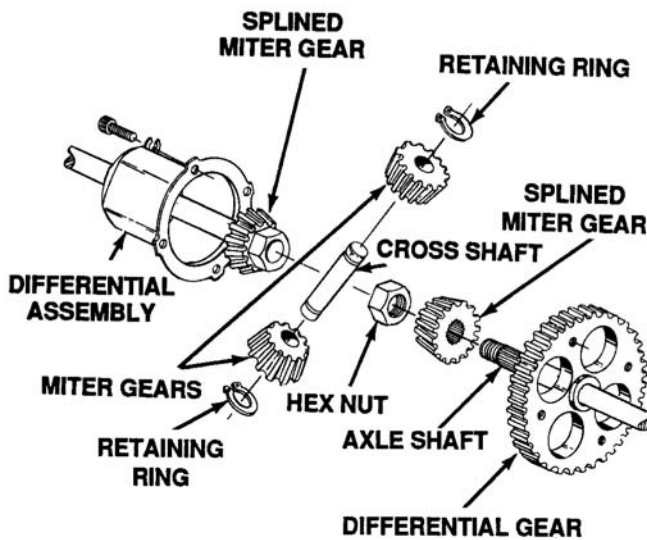


Figure 6-38. Differential Disassembly

15. Inspect two miter gears on axle shafts for any wear or damage. Replace if necessary.
16. Remove retaining ring.



**CAUTION**

DO NOT REUSE RETAINING RINGS from the cross shaft and slide shaft through miter gears.

17. Remove miter gears and inspect for damage. Replace if necessary.
18. Remove pinion shaft with 11 tooth gears, first remove the hi-pro key from shaft. Then pull gear and shaft out of housing. See Figure 6-39. Inspect gear teeth for any damage and inspect shaft for any damage on splines. Replace if necessary.

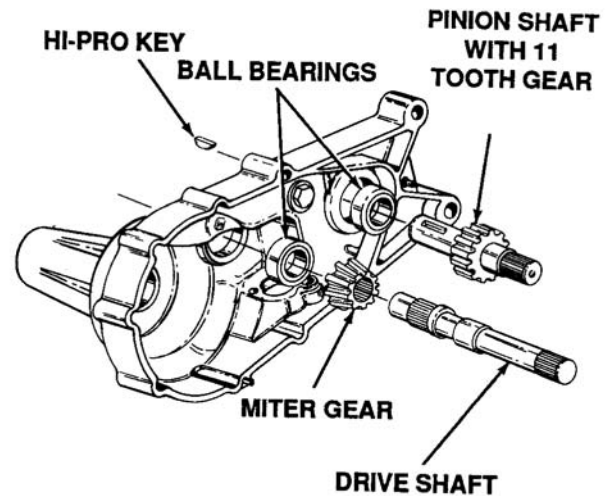


Figure 6-39. Pinion Shaft With 11 Tooth Gear Removal

19. Remove drive shaft and drive pinion (17 tooth) from housing. Inspect gear teeth for any damage. Replace if necessary. Also inspect splines on drive shaft for wear or damage. Replace if necessary.
20. Reassembly is the reverse order of disassembly. Bolts securing both housing halves are self-tapping bolts and must be torqued to 80 to 120 in-lbs. Over torquing bolts will strip out threads. If any of these threads are stripped, drill (using 1/4 inch drill) through damaged boss. Reinstall a 1/4-20 Grade 5 bolt and nut reaching through both housings. Use Locktite #242 on nut and torque to 80 to 120 in-lbs.



**WARNING**

**DO NOT LEAVE DRILL SHAVINGS IN TRAN-SAXLE.**

**6-5. INTEGRATED HYDROSTATIC TRANSAXLE (310-0500 and 310-0750) Figure 6-40.**

**6-5.1 General.**

1. The integrated hydrostatic transaxle is a self-contained unit designed for the transfer and control of power. It provides an infinitely variable speed range between zero and maximum in both forward and reverse modes of operation.

**➔ NOTE**

A transaxle normally will not require servicing during the life of the vehicle in which it is installed. Should servicing be required, the unit must be removed from its installed location and thoroughly cleaned before beginning most procedures.

2. The transaxle uses a variable pump with a maximum displacement of 10cc per revolution, and a motor with a fixed displacement of 21cc per revolution. The variable pump features a cradle swashplate with a direct proportional displacement control. Reversing the tilt of the swashplate reverses the flow of oil to the motor which changes the direction of its rotation. The pump and motor are of the axial piston design, and both utilize spherical nosed pistons which

are held against a thrust race by internal compression springs.

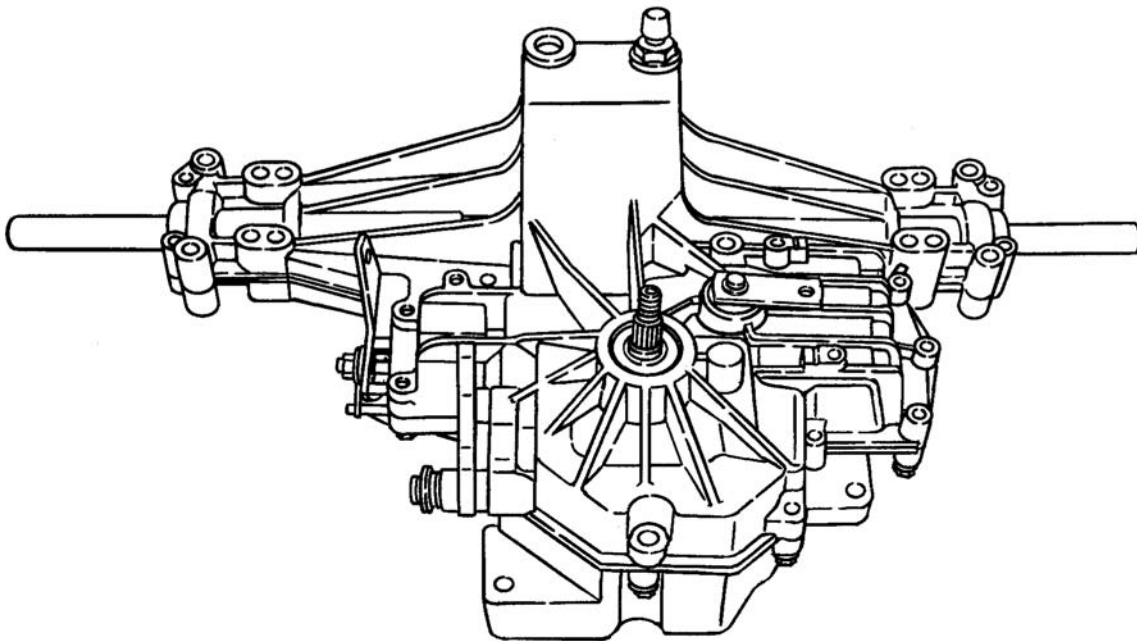
3. The fluid supply for the hydrostatic is contained within the housing and drawn through an integral filter before entering the pump. Two check valves are used to direct the flow to the low pressure side of the loop. The transaxle is filled and tested at the factory and should not require fluid or filter changes.
4. A cam style bypass is utilized in the transaxle to permit moving the vehicle for short distances at a maximum of 2 MPH without starting the engine. The oil bypasses under the motor allowing it to rotate freely.



**WARNING**

Actuating the bypass will result in the loss of hydrostatic braking capacity. The machine must be stationary and on a level surface when actuating the bypass.

5. The transaxle includes an integral differential which utilizes heavy duty heat treated bevel gears. The differential allows the drive wheels to rotate at different speeds while turning a corner without damaging the lawn on which it is being operated.



**Figure 6-40. Integrated Hydrostatic Transaxle 310-0500**



6. A cam style arm is utilized to actuate an inline floating multidisc parking brake. The brake discs are enclosed in a cavity that is sealed from the oil supply.

**6-5.2 Safety Precautions.** Observe the following WARNINGS and CAUTION.



**WARNING**

Certain procedures may require the vehicle to be disabled (wheels raised off the ground, engine disconnected, etc.) in order to prevent possible injury to the technician and bystanders.



**WARNING**

Some cleaning solvents are flammable. To avoid possible fire, do not use cleaning solvents in an area where a source of ignition may be present.



**CAUTION**

The loss of hydrostatic driveline power may result in the loss of hydrostatic braking capacity. Proper brake maintenance becomes very important should this condition develop.

**6-5.3 General Maintenance.**

1. Check transaxle cooling fan for broken or distorted blades. Check to see that fan is securely fastened. Replace fan if damaged.

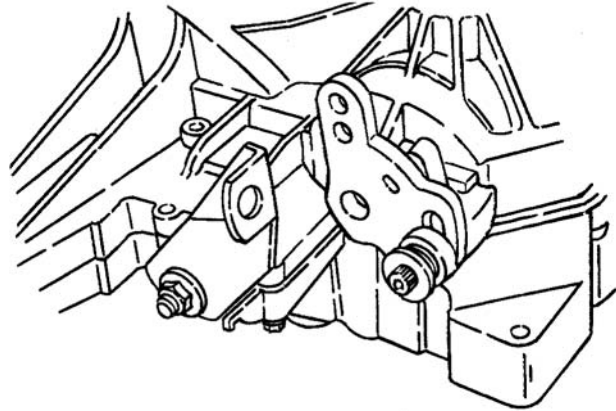


**NOTE**

Not all vehicles are equipped with a cooling fan. Refer to your vehicle manual for more information.

2. Keep transaxle clean. Grass clippings and dirt will affect the cooling efficiency of the fins on the housing.

3. Inspect brake for proper operation. If brake fails to stop vehicle or hold on a 30% slope, adjustments are necessary. You should also make sure it fully disengages when the pedal is released. See Figure 6-41.



**Figure 6-41. Brake Arm and Control Arm**

4. Check to make sure bypass actuator and linkage are operational. The bypass should be fully disengaged during operation of the vehicle. See Figure 6-42.
5. Inspect transaxle for leaks or damage to housing. If a lip seal is leaking refer to the instructions for replacement of lip seals. Check oil level and fill to correct level.
6. The oil may be checked by removing breather plug. See Figure 6-43. Typically, an API classification SG/CD engine oil is used with a viscosity range equivalent to 20W50.
7. The oil should be between 1.75 to 2.0 inches on 310-0500 and 1.0 to 1.25 inches on a 310-0750. See Figure 6-44.

## 6-5.4 Minor Repairs.

### ➔ NOTE

Minor repairs may be performed, following the procedures in this section, without voiding the unit warranty. Cleanliness is a primary means of assuring satisfactory life of either new or repaired units. Cleaning parts by using solvent wash and air drying is usually adequate. As with any precision equipment, all parts must be kept free of foreign materials and chemicals. Protect all exposed sealing surfaces and open cavities from damage and foreign material. The outer surfaces of the transaxle should be cleaned before beginning any repairs.

1. Shaft seals.

### ➔ NOTE

Lip type seals are used on the pump input shaft, displacement control shaft and bypass actuator shaft of the transaxle. These seals can be replaced without major disassembly of the unit. Replacement of these seals generally requires removal of the transaxle from the machine frame. See Figures 6-45, 6-46 and 6-47.

6

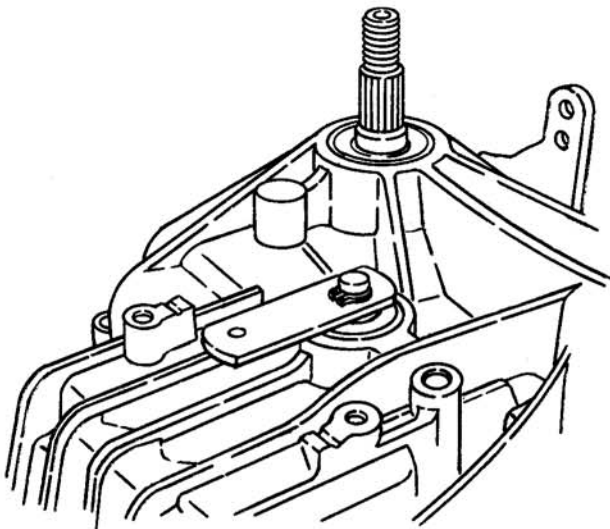


Figure 6-42. Bypass Arm

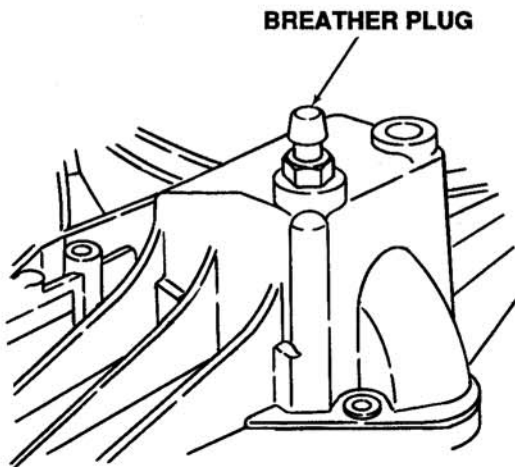


Figure 6-43. Breather Plug

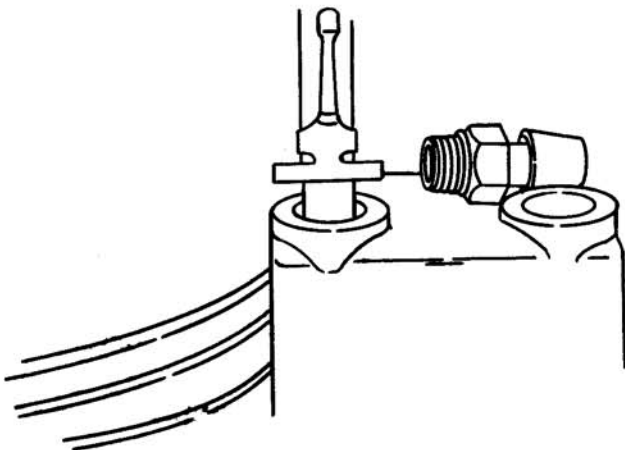


Figure 6-44. Checking Oil Level

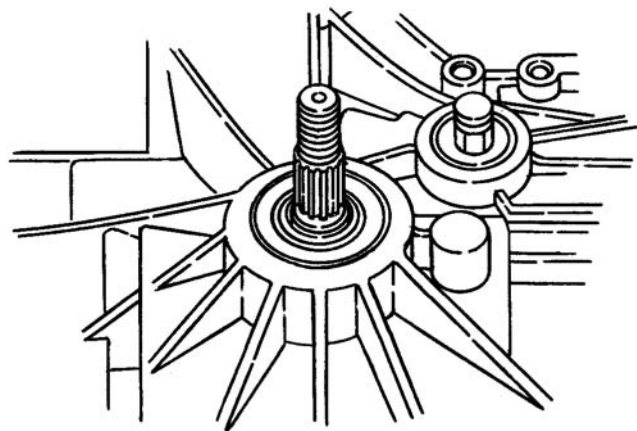


Figure 6-45. Pump Input Shaft and Seal

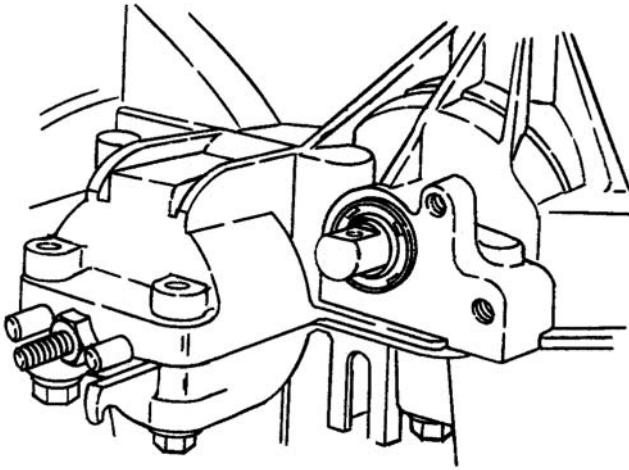


Figure 6-46. Displacement Control Shaft and Seal

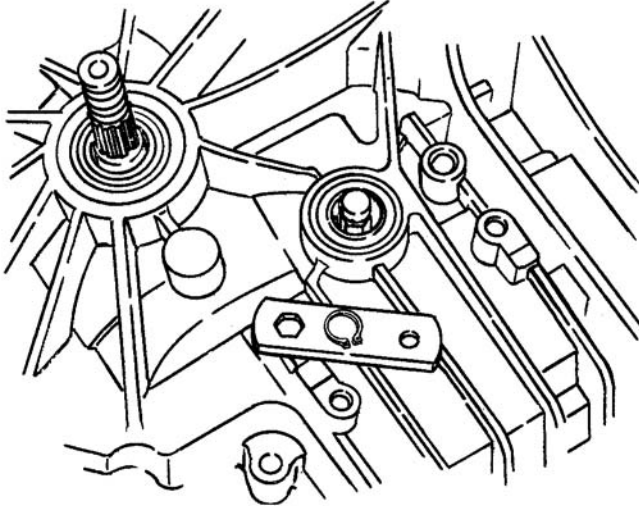


Figure 6-47. Bypass Actuator Shaft and Seal

- a. To remove input shaft seal carefully pull seal out of housing bore with a hook type tool or a slide hammer type puller. See Figure 6-48.



**CAUTION**

Care must be taken to avoid damage to the housing bore or shaft sealing surface.

- b. Lubricate the new seal prior to installation with a petroleum jelly.

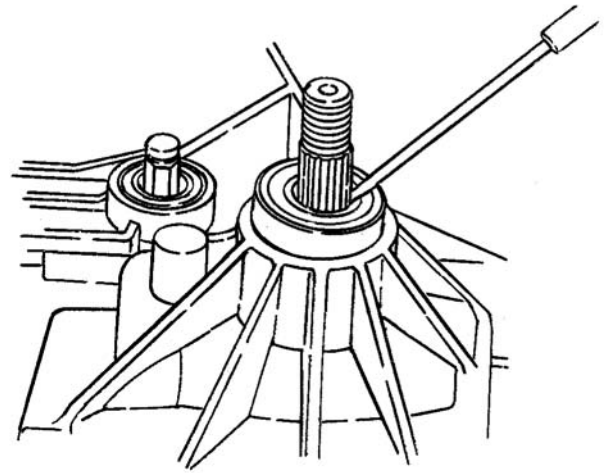


Figure 6-48. Input Shaft Seal Removal

- c. Wrap shaft spline with a thin plastic or cellophane tape to prevent damage to new seal lip during installation.
- d. Slide seal over shaft and press it into housing bore. Be careful not to damage seal. The seals should seal against retaining ring. See Figure 6-49.

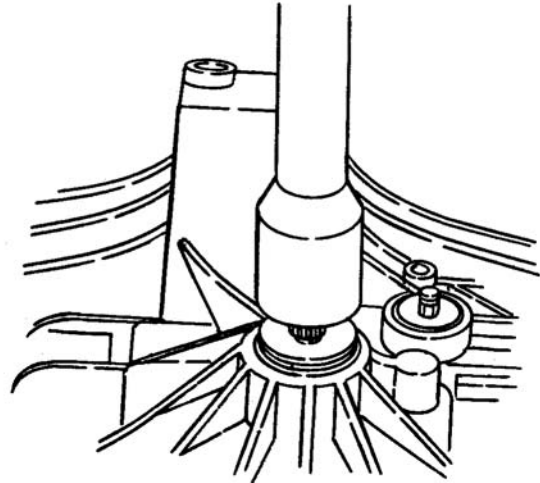


Figure 6-49. Input Shaft Seal Installation

- e. The displacement control shaft seal and bypass actuator shaft seal may be replaced following similar procedures.
2. Parking brake.

**NOTE**

The brake is factory set for a specific running clearance.

- a. To check for proper setting, place a feeler gauge between two of the discs. There should be from 0.015 to 0.025 inch clearance. See Figure 6-50.

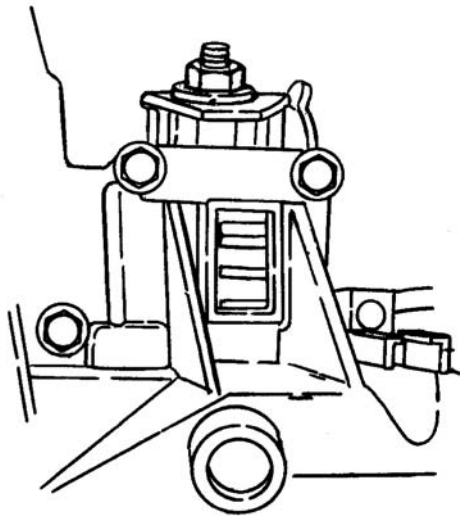


Figure 6-50. Brake Disc (Bottom View)

- b. If the clearance is not correct make the necessary change with adjustment nut. See Figure 6-51.

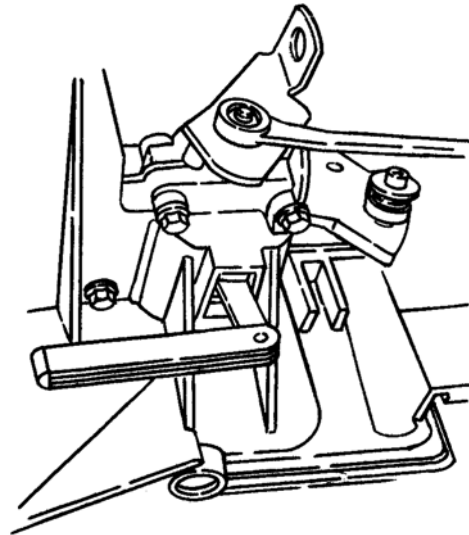


Figure 6-51. Brake Adjustment Nut With Feeler Gauge

Table 6-1. 310-0500 and 310-0750 Integrated Hydrostatic Transaxle Troubleshooting Chart



**WARNING**

**THE VEHICLE SHOULD BE ON LEVEL GROUND AND THE ENGINE DISABLED BEFORE PERFORMING ANY ADJUSTMENT**

SYMPTOMS	PROBABLE CAUSE
Vehicle will not attain normal maximum speed	The engine is not operating at the correct speed The control arm or linkage is damaged or loose The transaxle drive belt is worn or loose The brake is not fully released The bypass valve is stuck partially open A charge check valve is held open Water in the oil (cloudy or milky appearance)
Vehicle will not move when the vehicle control handle is moved	The control linkage is damaged or not connected The transaxle drive belt is broken or loose The input pulley is loose or damaged The brake is not fully released The transmission is low on fluid The bypass valve is stuck or not released
Vehicle is sluggish or noisy under load (operates fine on level surface)	The transaxle drive belt is worn or loose The brake is not fully released The bypass valve is stuck partially open A charge check valve is held partially open The transmission is low on fluid Water in the oil (cloudy or milky appearance)
Oil is leaking from the breather cap during normal operation	The cooling fan is loose or damaged The cooling fins are obstructed by grass clippings or dirt The oil level exceeds the recommended mark The vehicle is exceeding its maximum load rating The brake is stuck or not fully released The breather cap is not properly installed or has been damaged

SEE TABLE 6-3. FOR PARTS LIST

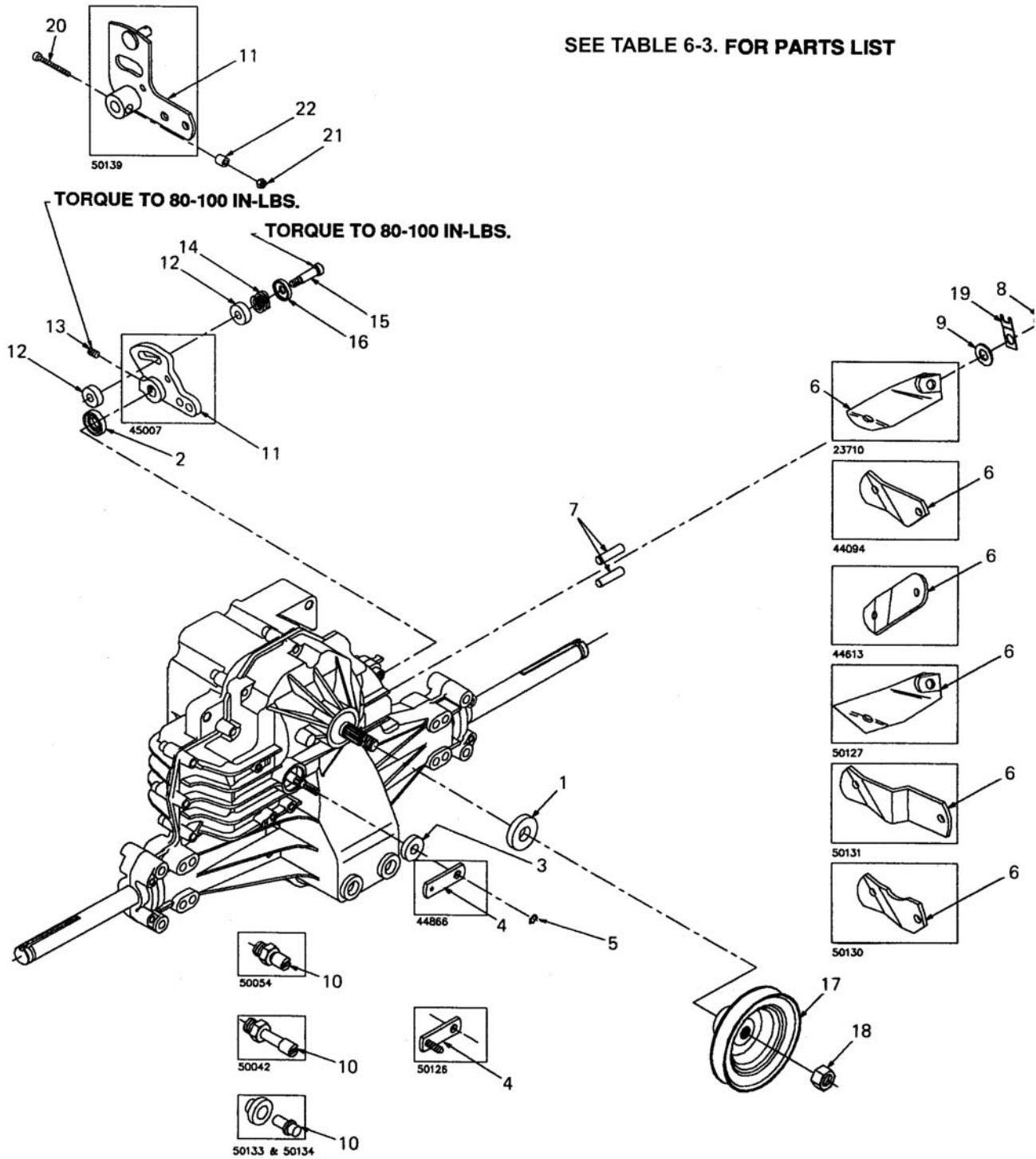


Figure 6-52. Integrated Hydrostatic Transaxle 310-0500 and 310-0750

Table 6-2. Variation Chart

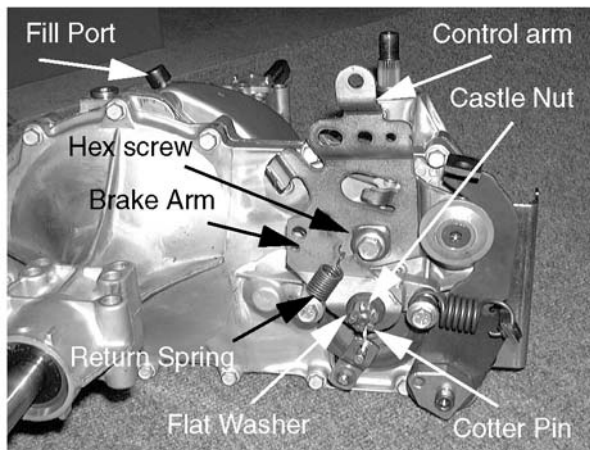
COMP. UNIT NUMBER	BRAKE ARM						BYPASS ARM		BREATHER			CONTROL ARM		
	23710	44094	44613	50127	50131	50130	44866	50126	50042	50054	50133 50134	45007	50139	NONE
310-0500														
1708579	X							X			X	X		
312-0500	X						X			X				X
718-0254		X						X	X			X		
314-0500				X			X				X	X		
88-6430					X		X			X			X	
774711		X					X			X		X		
310-0750														
718-0255						X		X	X			X		

Table 6-3. Parts List for Figure 6-52.

ITEM NO.	HYDRO-GEAR PART NO.	DESCRIPTION	QTY	ITEM NO.	HYDRO-GEAR PART NO.	DESCRIPTION	QTY
1	9008000-0128	Seal, Lip .....	1	11	45007	Arm, Control .....	1
2	9008000-0126	Seal, Lip .....	1		60139	Arm, Control .....	1
3	45074	Seal, Lip, 10 X 25 X 7...	1	12	50034	Puck, Dampener .....	2
4	44866	Arm, Bypass .....	1	13	50018	Set Screw .....	1
	50126	Arm, Bypass .....	1	14	50067	Spring .....	1
5	44870	Ring, Retaining .....	1	15	50032	Screw, Socket Hd .....	1
6	23710	Arm, Actuating .....	1			Shoulder	
	44094	Arm, Actuating .....	1	16	50078	Cup Washer .....	1
	44613	Arm, Actuating .....	1	17	50122	Pulley .....	1
	50127	Arm, Actuating .....	1	18	44133	Nut, Hex Hd Jam, .....	1
	50131	Arm, Actuating .....	1			1/2-20	
	50130	Arm, Actuating .....	1	19	50129	Strap, Locking .....	1
7	44891	Pin, Actuating .....	2	20	50140	Screw, Socket Hd .....	1
8	50108	Nut, Hex Lock, 5/16-24	1			Cap	
9	44130	Washer, 7/16 X .....	1	21	50141	Nut, 10-24 .....	1
		7/8 X .060		22	50142	Spacer .....	1
10	50054	Breather Assembly .....	1				
	50042	Breather Assembly .....	1				
	50133	Breather Assembly .....	1				
	50134	Breather Assembly .....	1				

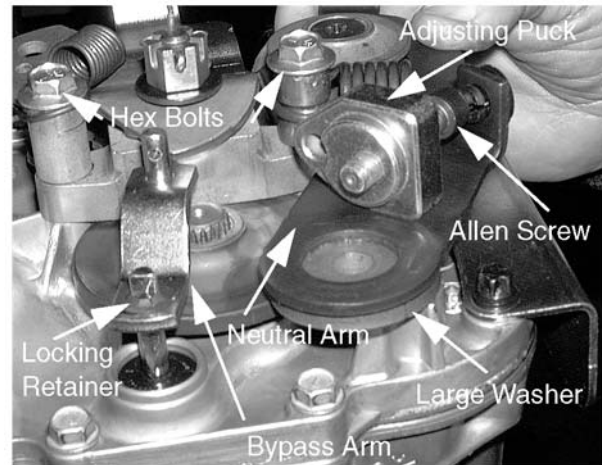
## Disassembly of the IHT

1. Remove the hydrostatic fill port using a 1/4" allen wrench. See Figure 6-53.



**Figure 6-53.**

2. Rotate the hydrostatic transaxle 180 degrees and drain the hydrostatic fluid into a suitable drain pan.
3. Remove the cotter pin securing the castle nut, washer, and brake actuation arm to the square head bolt using a pair of needle nose pliers.
4. Remove the castle nut and washer using a 9/16" wrench.
5. Remove the brake return spring from the brake actuation arm.
6. Remove the brake actuation arm.
7. Remove the hex cap screw securing the control arm to the trunnion shaft using a 1/2" wrench.
8. Remove the allen head screw securing the adjusting puck, neutral control arm, and large spacer to the housing using a 1/4" allen wrench. See Figure 6-54.

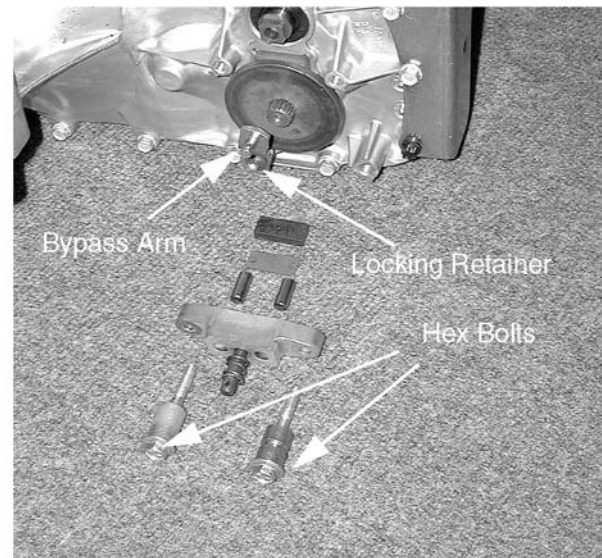


**Figure 6-54.**

### ➔ NOTE

This step removes the stress being applied to the brake assembly

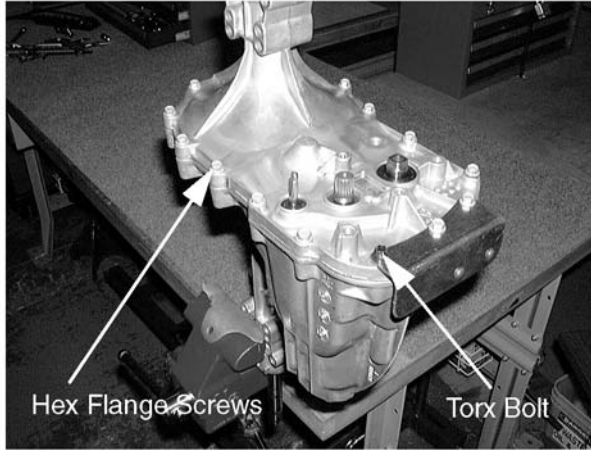
9. Remove the neutral control arm and large washer.
10. Remove both of the hex bolts securing the brake assembly to the IHT case using a 7/16" socket. See Figure 6-55.



**Figure 6-55.**

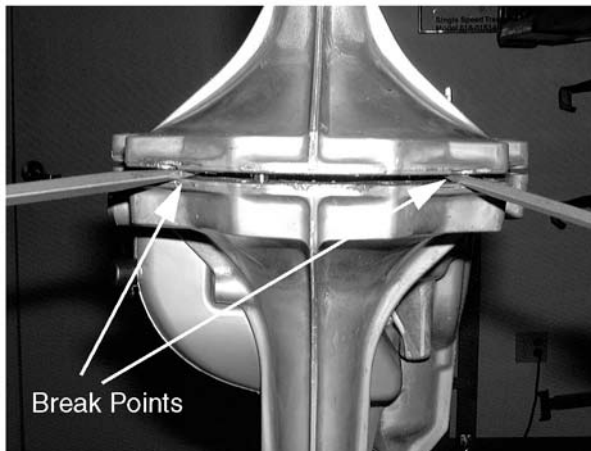
11. Remove the locking retainer securing the bypass arm using a small flat-blade screwdriver.
12. Place the hydrostatic transaxle in a vice with the outer perimeter hex flange screws facing up. See Figure 6-56.





**Figure 6-56.**

13. Remove the male torx bolt from the front mounting bracket using a 5/16" 12 point socket.
14. Remove all fourteen perimeter hex bolts securing the two IHT case halves together using a 3/8" socket.
15. Separate the housings from one another using the rear break points and a flat blade screwdriver. See Figure 6-57.



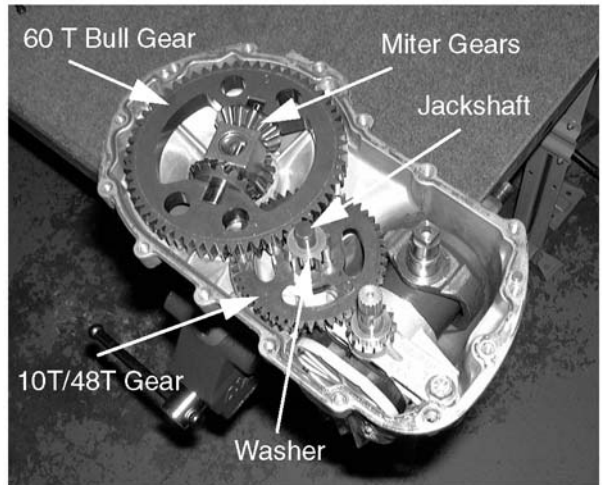
**Figure 6-57.**

16. Grasp the right axle and the front of the right case half and remove them from the left IHT case assembly. See Figure 6-58.



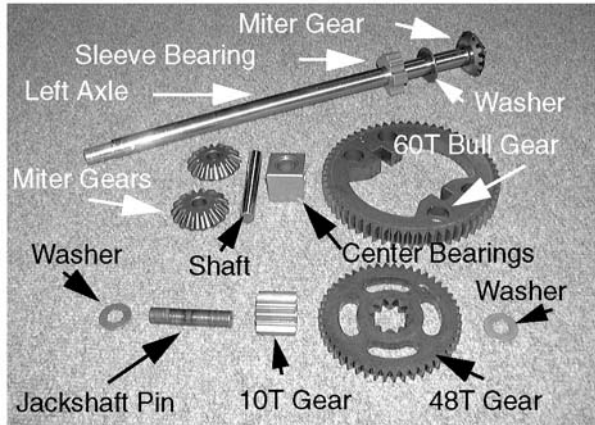
**Figure 6-58.**

17. Remove the 60T bull gear. See Figure 6-59.



**Figure 6-59.**

18. Remove the miter gears as an assembly.
19. Separate and inspect all the components for damage or wear. See Figure 6-60.



**Figure 6-60.**

20. Remove the jack-shaft assembly.
21. Separate and inspect all components for damage or wear.
22. Slowly remove the left axle assembly and inspect it for damage or wear.
23. Inspect the outer seal for damage or wear. See Figure 6-61.

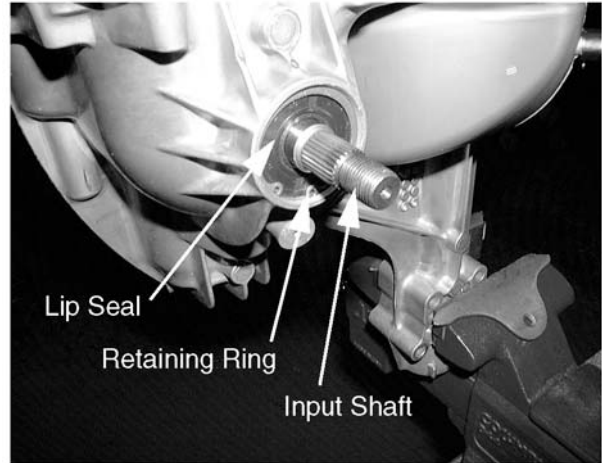


**Figure 6-61.**

**➡ NOTE**

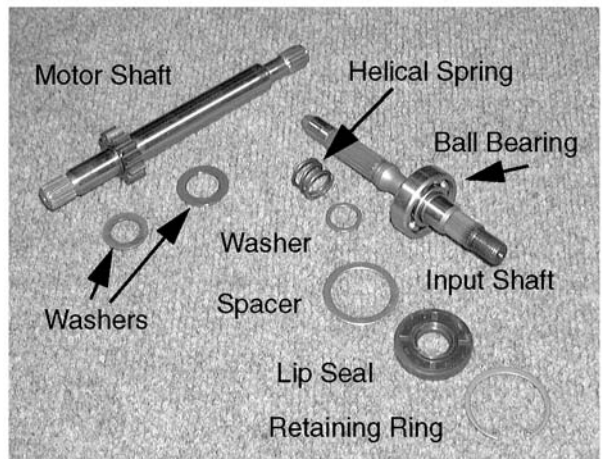
It is recommended that the seal is replaced.

24. Remove the retaining ring, lip seal, and spacer from the input shaft using a pair of retaining ring pliers and a flat blade screwdriver. See Figure 6-62.



**Figure 6-62.**

25. Remove the input shaft assembly and inspect it for damage or wear. See Figure 6-63.

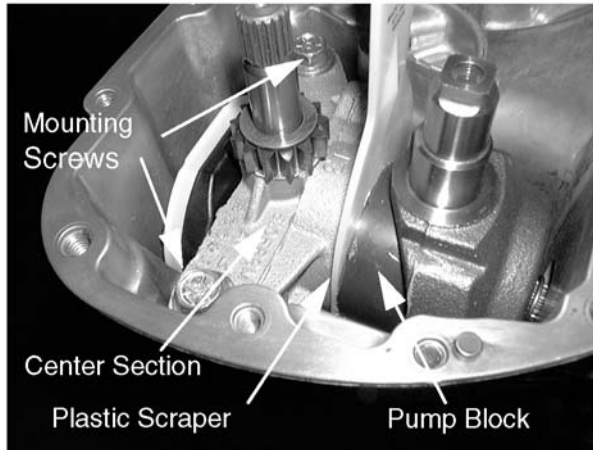


**Figure 6-63.**

**➡ NOTE**

Make certain the small washer and helical spring on the input shaft are on the input shaft prior to installation.

26. Slowly insert a smooth scraper between the pump block assembly and the upper face of the center section. See Figure 6-64.



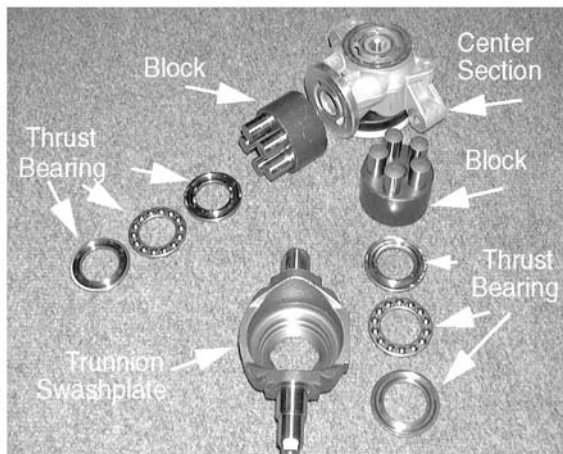
**Figure 6-64.**

27. Remove both of the hydro assembly mounting screws securing the center section to the left housing using a 9/16" socket and extension.
28. Hold the center section down, applying light pressure, and remove the motor shaft and washer.
29. Remove the center section and swashplate assembly together, keeping the smooth scraper between the two components at all times.

**➡ NOTE**

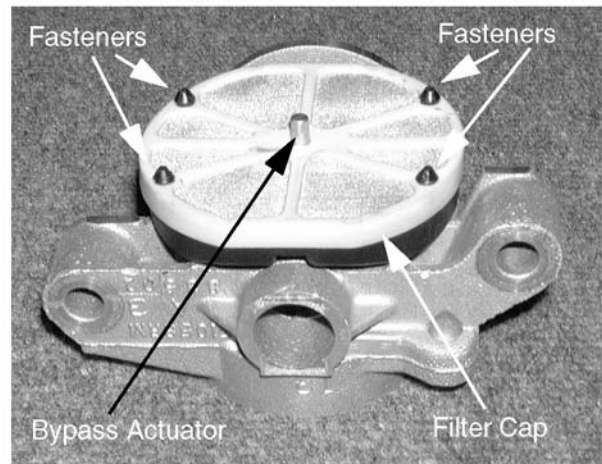
Damage will occur to the center section face if the swashplate and center section are not removed as one.

30. Separate all the components and check for damage or wear. See Figure 6-65.



**Figure 6-65.**

31. Remove the filter cap from the filter base by squeezing the fasteners together using a pair of pliers, and prying up with a flat-blade screwdriver. See Figure 6-66.

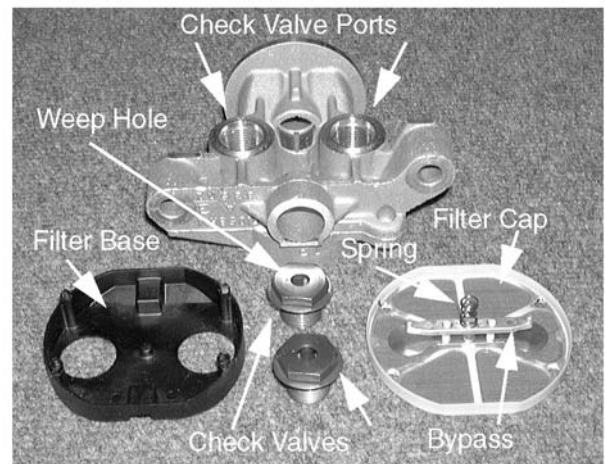


**Figure 6-66.**

**➡ NOTE**

The filter assembly should not be reused during assembly.

32. Remove both of the check valves and make certain they are free. See Figure 6-67.



**Figure 6-67.**

**➡ NOTE**

The faces of the check valves may have a weep hole. It makes no difference which port they are installed in during assembly.

33. Clean the mating faces of the two case halves for assembly. See Figure 6-68.

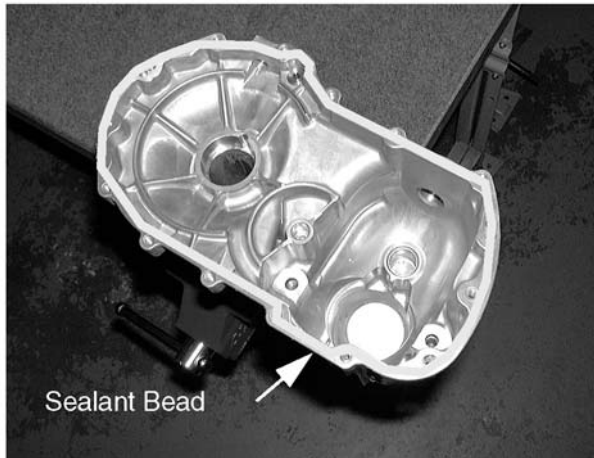


Figure 6-68.

### Assembly of the IHT

1. Assemble the hydrostatic drive mechanism on a workbench, and make certain all of the components are clean and ready for installation. See Figure 6-69.

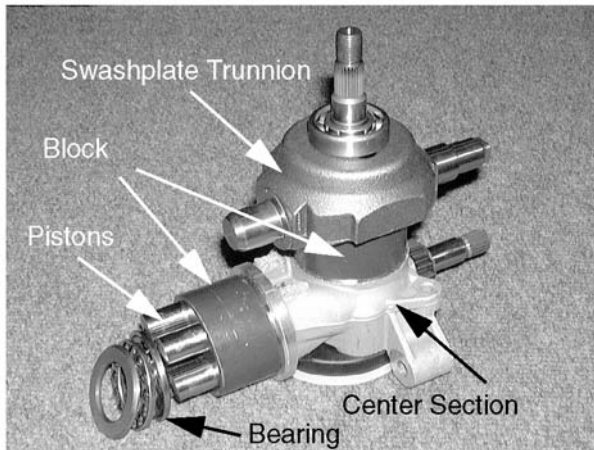


Figure 6-69.

2. Inspect the swashplate making certain the pivoting shafts are smooth. See Figure 6-70.

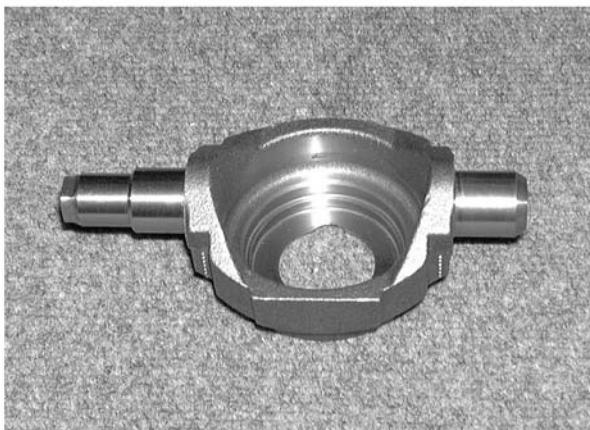


Figure 6-70.

3. Assemble the center section-filter bypass assembly. See Figure 6-71.

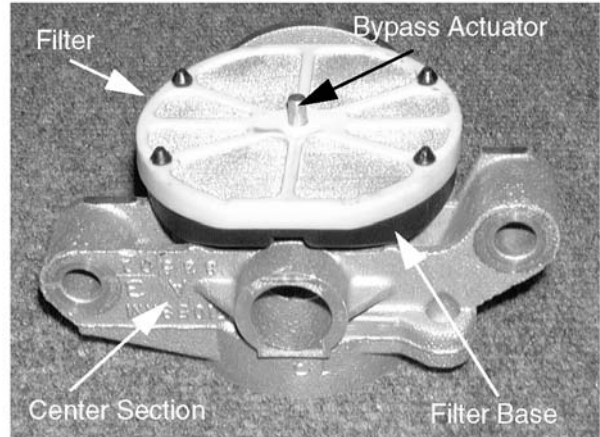


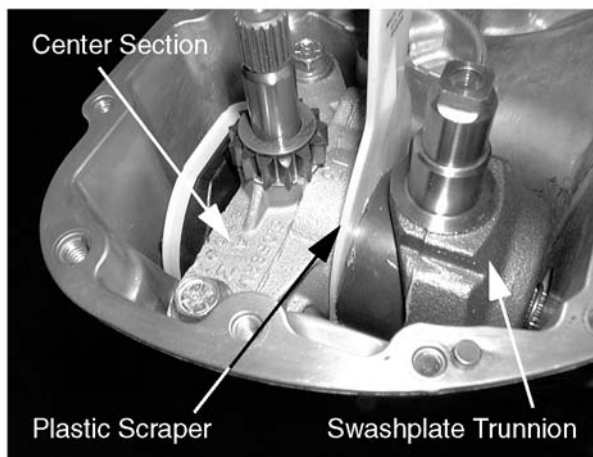
Figure 6-71.

4. Set the thrust bearing assembly into the main housing assembly.
5. Assemble the motor block assembly and place it onto the thrust bearing.

### NOTE

Make absolutely certain the pistons do not come out of the motor block during installation, or damage will occur.

6. Set the thrust bearing assembly and pump block assembly into position in the swashplate.
7. Place a smooth scraper into the IHT fluid, and set it on the center section face.
8. Set the swashplate, bearing assembly, and pump block assembly onto the smooth scraper.
9. Grasp the complete assembly and apply inward pressure to collapse the pump pistons.
10. Insert the hydrostatic drive assembly into the main housing, leaving the smooth scraper in place. See Figure 6-72.



**Figure 6-72.**

11. Insert the motor shaft through the center section and into the motor block assembly. See Figure 6-73.



**Figure 6-73.**

12. Lightly secure the center section assembly using the hydro mounting screws removed during disassembly and a 9/16" socket.

**➡ NOTE**

Make certain the hydro screws are not fully tightened down.

13. Align the pump block up with the center section and install the input shaft. See Figure 6-74.

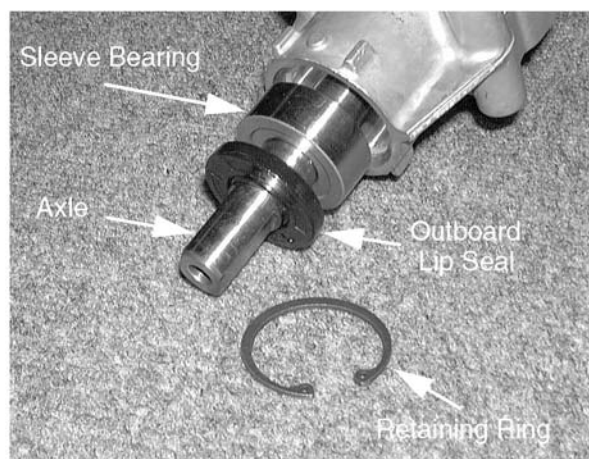


**Figure 6-74**

**➡ NOTE**

Make certain the washer and helical spring are on the input shaft prior to installation.

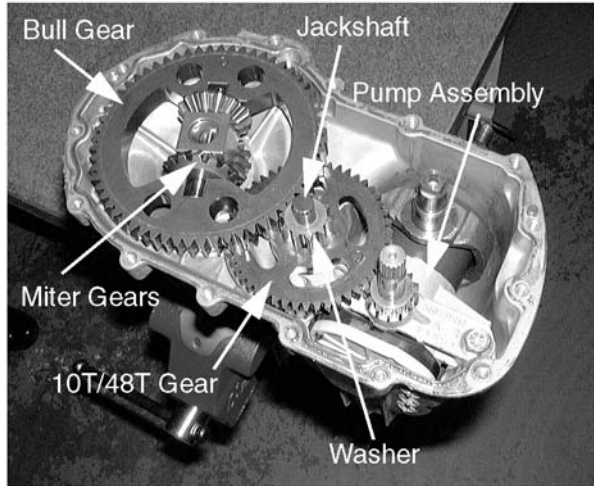
14. Secure the input shaft into place using the spacer, a new lip seal, and a retaining ring.
15. Torque down the hydro mounting screws using a 9/16" socket and a torque wrench.
16. Slide the left axle into the left housing. See Figure 6-75.



**Figure 6-75.**

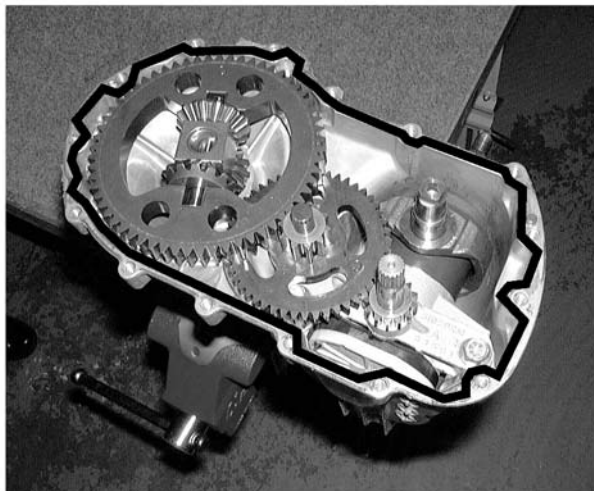
17. Secure the sleeve bearing, outboard lip seal, and retaining ring to the axle housing using retaining ring pliers.
18. Install the remaining internal components into the main housing in the reverse order of removal. See Figure 6-76.





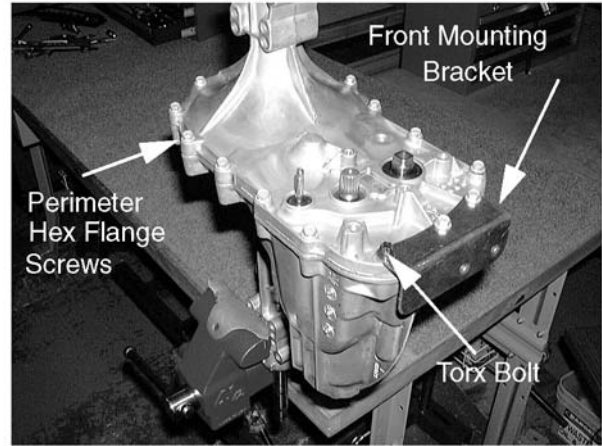
**Figure 6-76.**

19. Place a small bead of Loctite 515 around the perimeter of the main housing mating face. See Figure 6-77.



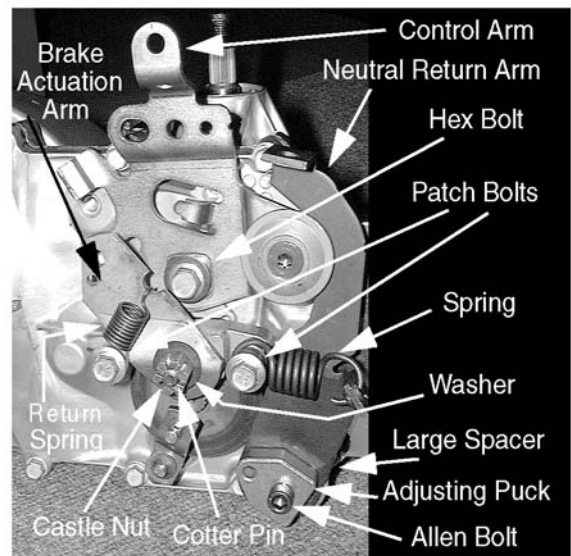
**Figure 6-77.**

20. Grasp the right axle and side housing while slowly lowering them to the main housing mating face.
21. Place the front mounting bracket onto the side housing and secure it with the male torx bolt using a 5/16" - 12 point socket. See Figure 6-78.



**Figure 6-78.**

22. Install all perimeter hex flange screws and torque to specifications using a 3/8" socket and a torque wrench.
23. Place the brake assembly into position and secure with both of the patch bolts removed during disassembly. See Figure 6-79.

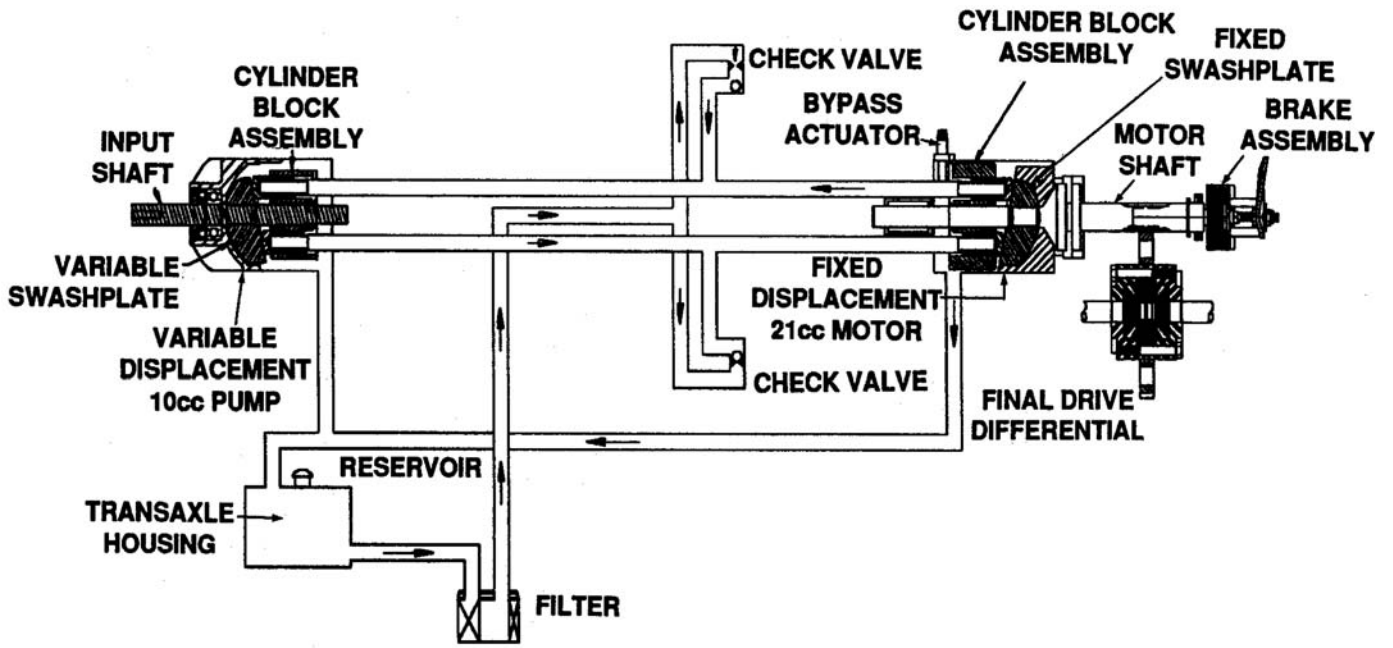


**Figure 6-79.**

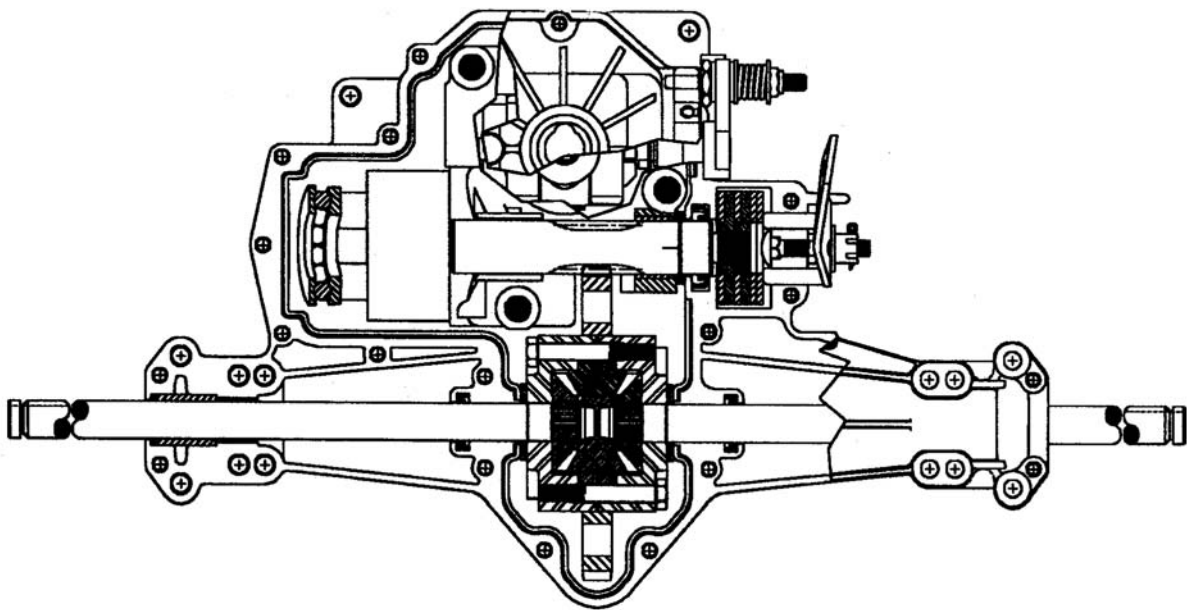
**➡ NOTE**

The gold spacer with the groove is installed on the rear bolt.

24. Hook the neutral return arm onto the spring and secure it with an allen bolt, adjusting puck, and large spacer using a 1/4" allen wrench.



Integrated Hydrostatic Transaxle Flow Illustration



310-0500 Integrated Hydrostatic Transaxle

25. Secure the control arm to the trunnion shaft with the hex bolt using a 1/2" wrench.
26. Install the brake actuation arm and brake return spring.
27. Secure the brake actuation arm using the castle nut, washer, and a new cotter pin.
28. Fill the IHT with 78.8 oz. of 20W50 API - SH/CD fluid.

### Brake Adjustments for the IHT

1. Remove the brake arm bias spring from the brake arm using a pair of needle-nose pliers. See Figure 6-80.



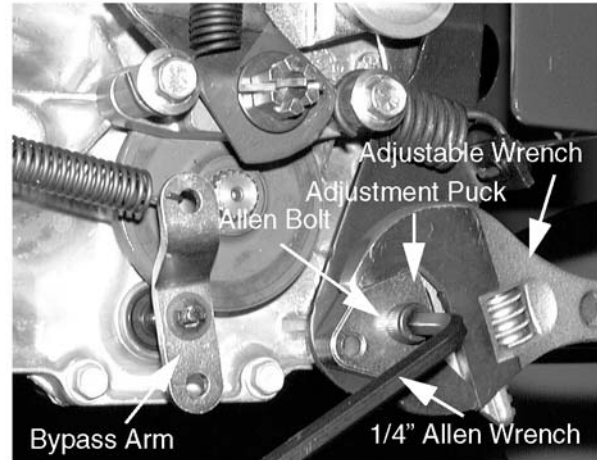
**Figure 6-80.**

2. Remove the cotter pin securing the castle nut to the square head bolt of the brake assembly.
3. Loosen the castle nut several turns.
4. Place a 0.015" feeler gauge between the brake disc and the brake puck.
5. Tighten the castle nut until the 0.015" feeler gauge is snug, and remove the feeler gauge.
6. Install a new cotter pin to secure the castle nut in place, and install the brake arm bias spring using a pair of needle-nose pliers.

### Neutral Control Adjustment for the IHT

1. Make certain the IHT is in the operating mode by checking that the bypass is disengaged. See Figure 6-81.
2. Raise the right rear wheel off the ground.

3. Remove the right rear hub cap using a pair of channel locks.
4. Remove the hex bolt, bell washer, and flat washer securing the right rear wheel assembly using a 1/2" socket.
5. Remove the right rear wheel assembly from the right axle.



**Figure 6-81.**

### NOTE

Lubricate the right axle before reinstallation.

6. Start and run the engine, increasing the throttle to full engine rpm.
7. Watch the right rear axle and inspect for motion.
8. If the axle does not rotate, assemble the unit in the reverse order above.
9. If the axle rotates, perform the following steps:
10. Locate the allen bolt that secures the neutral adjustment puck.
11. Loosen the allen bolt until the adjustment puck can rotate using a 1/4" allen wrench.
12. Slowly rotate the adjustment puck clockwise or counter-clockwise until the right axle comes to a complete stop using a large adjustable wrench.
13. Secure the adjustment puck by tightening the allen bolt with a 1/4" allen wrench.
14. Assemble the unit in the reverse order above.



## 6-6 Fluids/Greases.

1. The fluids used in HYDRO-GEAR products have been carefully selected, and only equivalent or better products should be used.
2. Typically, an engine oil with a minimum rating of 55 SUS at 210°F and an API classification of SH/CD is recommended. A 20W-50 engine oil has been selected for use by the factory.
3. The grease used in the manufacture of Hydro-Gear products is a Rykon Premium grease and should be substituted for with equivalent products only if it is not readily available in your area.

### NOTE

This grease is not compatible with all grease types.

### 6-6.1 Safety Precautions.

1. Certain procedures may require the vehicle to be disabled (wheels raised off the ground, engine disconnected, etc.) in order to prevent possible injury to the technician and bystanders.
2. Some cleaning solvents are flammable. To avoid possible fire, do not use cleaning solvents in an area where a source of ignition may be present.
3. The loss of hydrostatic driveline power may result in the loss of hydrostatic braking capacity. Proper brake maintenance becomes very important should this condition develop.

### 6-6.2 Maintenance.

1. Check the transaxle cooling fan for broken or distorted blades, and check to see that the fan is securely fastened. Replace the fan if damaged.

### NOTE

Not all vehicles are equipped with a cooling fan, refer to your vehicle manual.

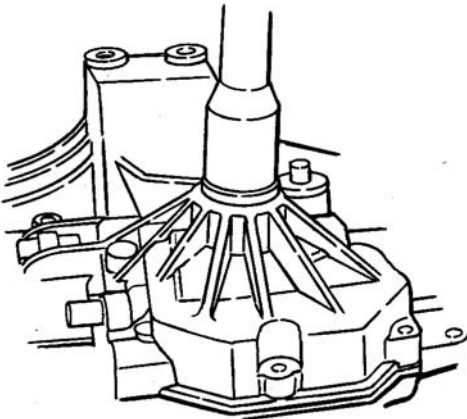
2. Keep the transaxle clean. Grass clippings and dirt will affect the cooling efficiency of the fins on the housing. Avoid high pressure washing, compressed air is the preferred method of removing loose debris.

3. Inspect the brake for proper operation. If the brake fails to stop the vehicle or hold on a 30% slope, adjustments are necessary. You should also make sure it fully disengages when the pedal is released.
4. Check to make sure the bypass actuator and linkage is operational. The bypass must be fully released during operation of the vehicle.
5. Inspect the transaxle for leaks at lip seals or damage to the housing.
6. Check the oil level and add oil as necessary to bring it up to the proper level.

### 6-6.3 Minor Repairs.

1. General Information.
  - a. Minor repairs may be performed, following the procedures in this section, without voiding the unit warranty.
  - b. Cleanliness is a primary means of assuring satisfactory life of either new or repaired units. Cleaning parts by using solvent wash and air drying is usually adequate. As with any precision equipment, all parts must be kept free of foreign materials and chemicals.
  - c. Protect all exposed sealing surfaces and open cavities from damage and foreign material. The outer surfaces of the transaxle should be cleaned before beginning any repairs.
2. Shaft Seals.
  - a. Lip type seals are used on the pump input-shaft, the displacement control shaft and the bypass actuator shaft of the transaxle. These seals can be replaced without major disassembly of the unit. Replacement of these seals generally requires removal of the transaxle from the machine frame.
  - b. To remove the input shaft seal carefully pull the seal out of the housing bore with a "hook" type tool or a slide hammer type puller. Care must be taken to avoid damage to the housing bore or to the shaft sealing surface.
  - c. Lubricate the new seal prior to installation with a petroleum jelly.
  - d. Wrap the shaft spline (keyway) with a thin plastic or cellophane tape to prevent damage to the new seal lip during installation.

- e. Slide the seal over the shaft and press it into the housing bore. Be careful not to damage the seal. The seal should seat against the retaining ring.
- f. The displacement control shaft seal and the bypass actuator shaft seal may be replaced following similar procedures. See Figure 6-82.

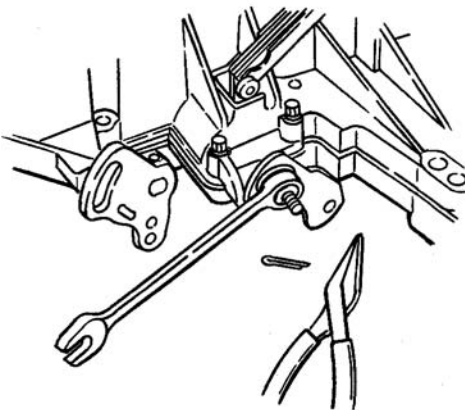


**Input Shaft Seal Installation**

**Figure 6-82**

3. Parking Brake.

- a. The brake was set at a specific running clearance (approximately .030 inch) between the discs to the Original Equipment Manufacturers specifications. Refer to the vehicle service manual for the correct clearance.
- b. Press a feeler gauge between the two outer discs, if the clearance is not correct make the necessary change with the brake retainer nut. See Figure 6-83.

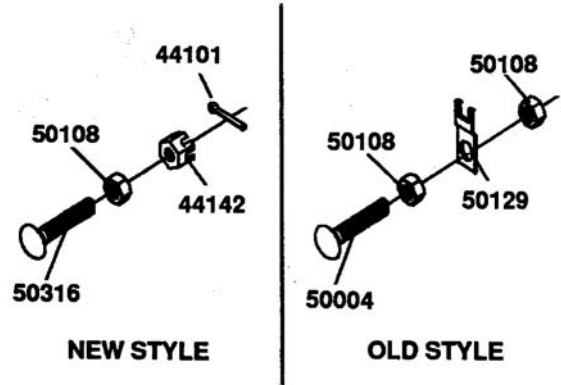


**Brake Adjustment (Bottom View)**

**Figure 6-83**

**NOTE**

Two versions of the brake retainer nuts have been used. Early production employed a "Nylock" type nut, while current production is using a castellated nut with a cotter pin for retainment.



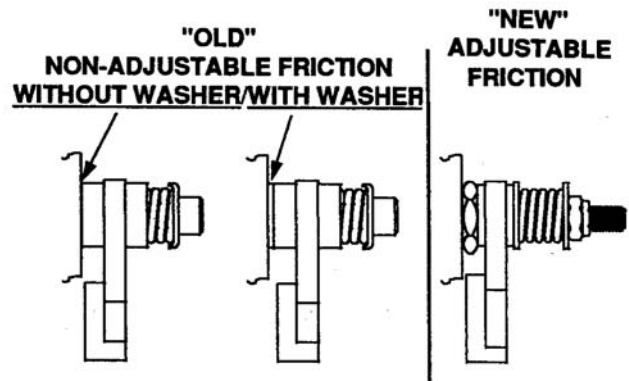
**Brake Retainer Nut Variations**

**Figure 6-84**

4. Control Arm and Friction Pack.

**NOTE**

The control arm and friction pack vary between models and is not used on some. The OEM have established individual specifications for the proper adjustments. Refer to vehicle service manual for the proper procedures.



**Friction Pack Variations**

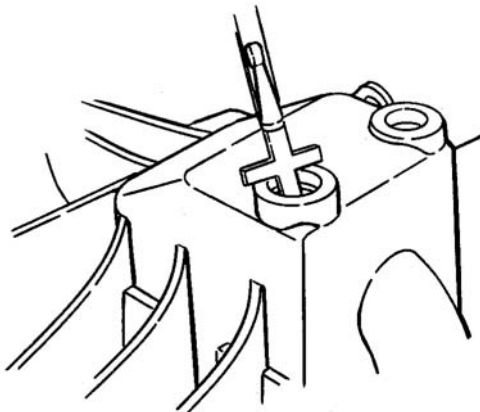
**Figure 6-85**

5. Oil Level.

- a. To check the oil level you must first remove the breather fitting from the housing.

**NOTE**

- a. Make sure the surrounding area has been thoroughly cleaned prior to removal of the fitting to prevent the introduction of contamination into the oil.
- b. The oil level should be between 1.75 inch and 2.0 inch from the top of the housing for the 310-0500, and between 1.25 inch and 1.62 inch from the top of the housing for the 310-0750. See Figure 6-86.



**Oil Level**  
**Figure 6-86**

**Major Repairs.**

1. Major Repairs described in the following sections are for the complete disassembly and reassembly (Major Repair) of the IHT and will void all product warranty, unless license to perform said Major Repair was previously obtained from an Authorized Representative of Hydro-Gear.
2. Cleanliness is a primary means of assuring satisfactory life on new or repaired units. Cleaning parts by using a solvent wash and air drying is usually adequate. As with any precision equipment, all parts must be kept free of foreign materials and chemicals.
3. Protect all exposed sealing surfaces and open cavities from damage and foreign material. The outer surfaces should be cleaned before beginning any repairs.

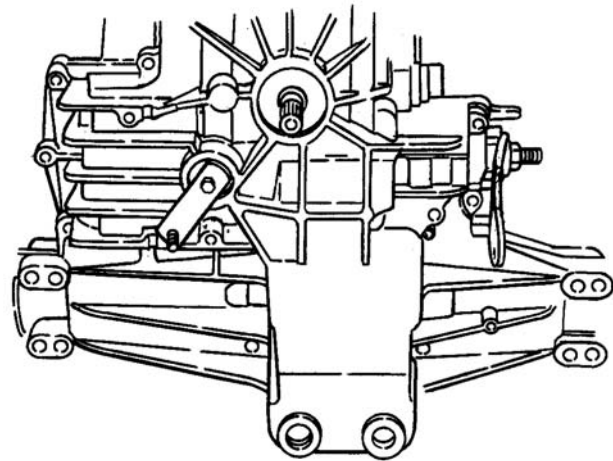
4. It is recommended that all seals be replaced. Lightly lubricate all seals with a clean petroleum jelly prior to assembly.
5. It is recommended that parts requiring replacement be replaced as a complete assembly.
6. Prior to performing Major Repairs on the IHT, remove the transaxle from its installed location and remove any external components such as the brake arm, brake actuating pins, control arm (and friction pack if included), cooling fan and input pulley or frame mounting hardware.

**NOTE**

Thoroughly clean all exposed surfaces prior to any further disassembly.

**Disassembly Procedures.**

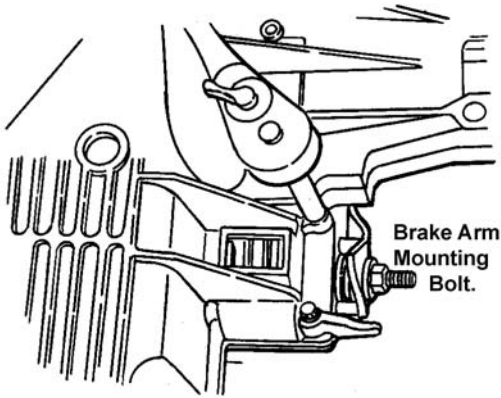
1. Drain the oil by removing the breather assembly and positioning the IHT so that the breather port is down to allow the oil to drain thoroughly. See Figure 6-87.



**Drain Oil From Breather Port**

**Figure 6-87**

2. Position and secure the IHT with the upper housing down to allow access to the twenty housing assembly cap screws. See Figure 6-88.



**Remove Housing Assembly Bolts**

**Figure 6-88**

- Using the appropriate tool, remove the twenty assembly screws.

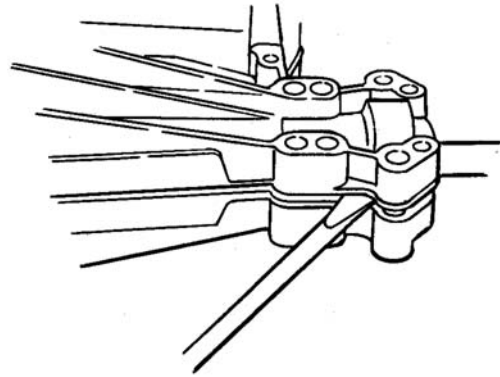
**➔ NOTE**

Prior to October 27, 1993 a 3/16 inch drive internal hex head cap screw was used, at that time a change was made to an "E-8" external drive "Torx" cap screw.

- Loosen the nut on the brake arm mounting bolt. See Figure 6-88.
- Separate the two housing halves by applying pressure (as shown) with two large straight blade screwdrivers. Use caution to prevent damage to the mating sealing surfaces as you separate the two halves. See Figure 6-89.

**➔ NOTE**

The sealant will make the two halves difficult to separate.



**Separate Housing Halves**

**Figure 6-89**

- All components should remain in the upper housing (positioned down). See Figure 6-90.

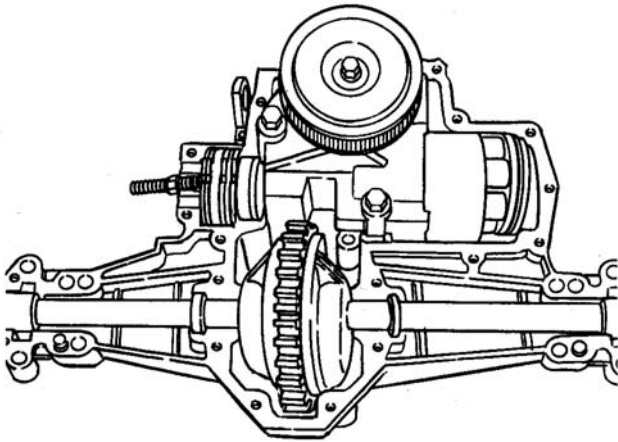
**⚠ CAUTION**

The axle/differential assembly may stick as the lower housing is being lifted off the upper housing.

- Inspect the lower housing for damage. Inspect the axle journal bearing pockets for excessive wear. Inspect the brake rotor/stator pocket for excessive wear.

**➔ NOTE**

Prior to reassembly the lower housing must be thoroughly cleaned and old sealant must be removed.



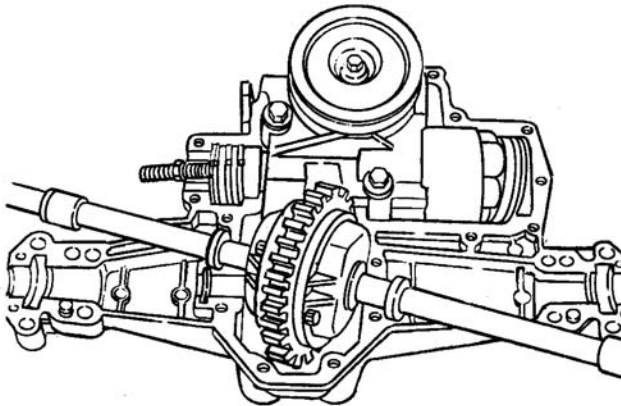
**310-0750 Components in Upper Housing**

**Figure 6-90**

8. Lift the axle/differential assembly out of the upper housing. See Figure 6-91.

**➔ NOTE**

It will be necessary to remove any burrs or rust from the axle ends prior to the removal of the two bronze bearings or damage to the bearings will occur. Remove the two bronze journal bearings, four lip seals and two flat washers from the axle ends.



**Remove Axle/Differential Assembly**

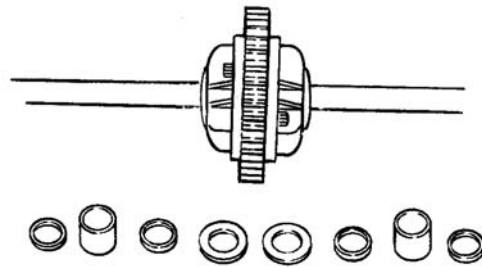
**Figure 6-91**

**➔ NOTE**

The lip seals must not be reused during reassembly.

9. Inspect the bronze bearings for excessive wear. The bearings should be .7535 to .7561 inch ID.

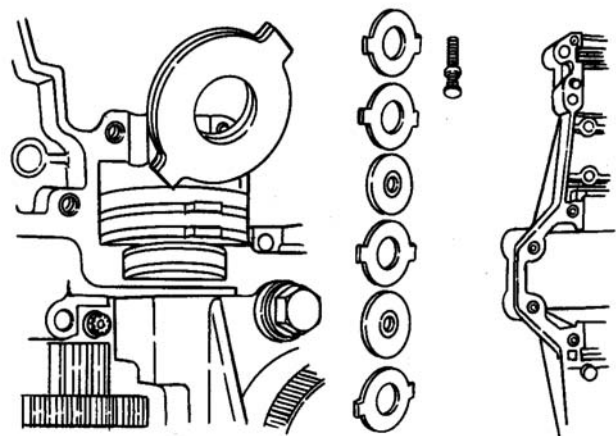
10. Inspect the axle ends for damage or excessive wear. The axle ends should be .7486 to 0.7496 inch.
11. Inspect the differential bevel gears by rotating the axle ends.
12. Inspect the final drive gear teeth for excessive wear or damage.
13. Check the differential assembly screws for proper torque. For the 310-0500 they should be torqued to 16-18 ft-lbs while the 310-0750 should be torqued to 12-14 ft-lbs.
14. Inspect the journal bearings inside the differential housing for excessive wear by feeling the shafts for an unreasonable amount of play.
15. If excessive wear or damage has been found, the complete assembly must be replaced. See Figure 6-92.



**310-0750 Axle/Differential Components**

**Figure 6-92**

16. Remove the brake rotors and stators by sliding one at a time off the end of the splined motor shaft. See Figure 6-93.

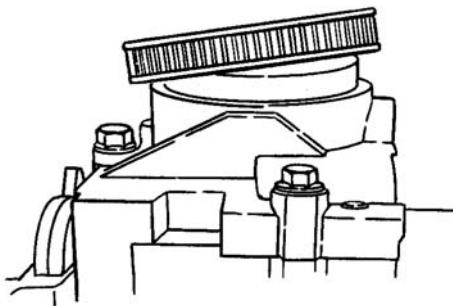


**Removal and Inspection of Brake Rotors**

**Figure 6-93**

17. Inspect each side of both rotors for excessive wear or damage.
18. Inspect the rotors internal splines for excessive wear or damage.
19. Inspect the stators for excessive wear and damage.
20. Replace rotors and stators as a complete kit if excessive wear or damage is found, and inspect all other mating parts.
21. Remove the oil filter. After inspecting the filter for unusual particles that it may have trapped, dispose of it properly and replace it with a new oil filter during reassembly. See Figure 6-94.

Using a 9/16 inch socket (or box end) wrench, remove the three assembly bolts retaining the center section in the upper housing.



Remove Oil Filter

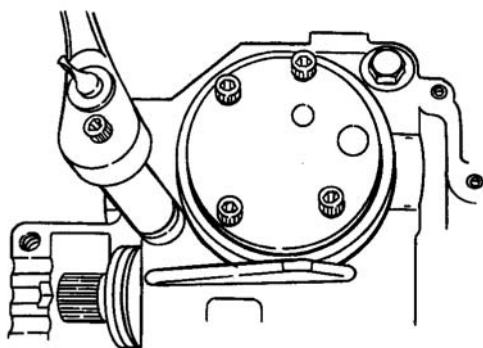
Figure 6-94

22. Using a 9/16 inch socket (or box end) wrench, remove the three assembly bolts retaining the center section in the upper housing. See Figure 6-95.



**CAUTION**

The pump and motor piston springs may push the center section assembly out of position while you remove these bolts.



Remove Center Section Assembly

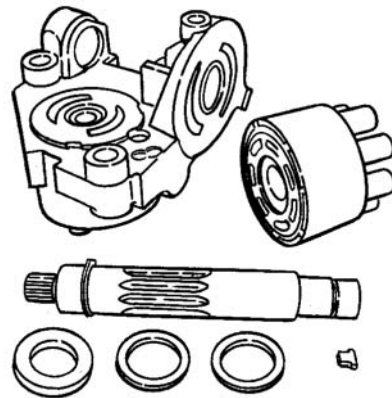
Figure 6-95

23. Remove the center section assembly from the housing. The pump block assembly should remain in the upper housing on the input shaft, but may stick to the center section. Check the check valve plate torque, but do not remove. Two styles of check plates have been used, one has three bolts while the other has four. The one with four bolts should be torqued from 170-240 in-lbs while the one with three bolts should be torqued from 135-185 in-lbs. See Figure 6-96.



**CAUTION**

The aligning pins, motor shaft, bypass plate, pump block and motor block assemblies are NOT retained to the center section or the upper housing and may become separated from the assembly during removal.



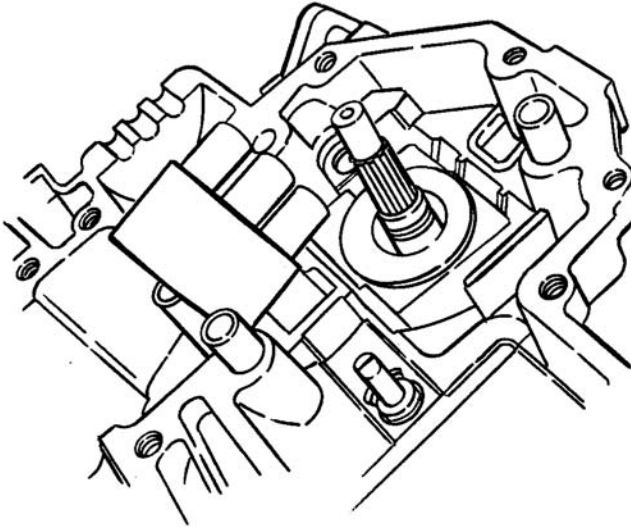
Center Section/Motor Shaft

Figure 6-96

24. Remove the motor block assembly from the motor shaft and inspect for unusual wear or damage. The pistons should fit with very little side clearance in the block bores, but must slide freely. NOTE: The correct bore diameter for the block is .6776 to .6784 and the pistons should be .6767 to 6770.
25. Remove the motor shaft, washers and bypass plate from the center section and inspect for unusual wear or damage. See Figure 6-97.
26. Inspect the center section running surfaces for unusual wear or damage.
27. Remove the pump block assembly, block thrust washer and spring from the input shaft and inspect for unusual wear or damage. The pistons should fit with very little side clearance in the block bores, but must slide freely. See Figure 6-98.

**→ NOTE**

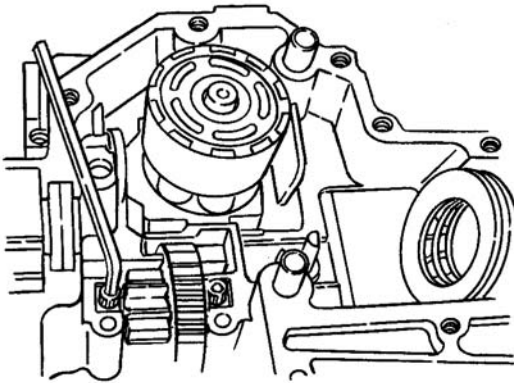
The correct bore diameter for the block is .6295 to .6303 and the pistons should be .6288 to .6291.



**Remove Pump Block Assembly**

**Figure 6-97**

28. For 310-0750 Models Only: Remove the two internal hex head cap screws retaining the jack-shaft to the housing with a 5mm hex wrench and remove the jackshaft/pinion gear assembly from the housing. See Figure 6-98.



**Remove Jackshaft/Pinion Gear Assembly**

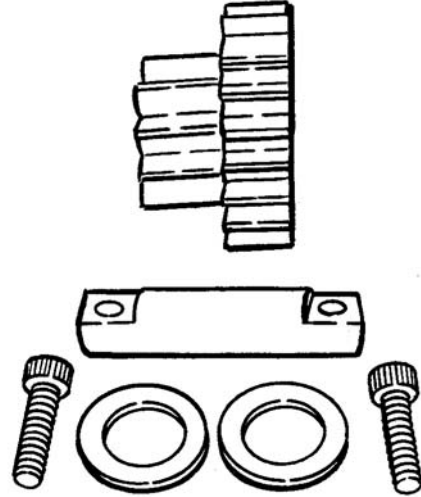
**Figure 6-98**

29. Inspect the jackshaft running surface for excessive wear or damage. The jackshaft should be .4986 to .4996 inch.

30. Inspect the pinion gear bore for excessive wear or damage. The bore should be .5014 to .5024 inch.

31. Inspect the pinion gear teeth for excessive wear or damage.

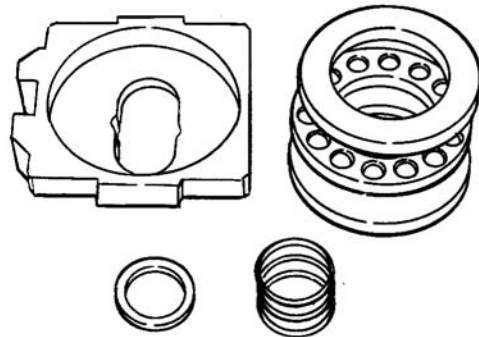
32. If excessive wear or damage was found, the complete assembly should be replaced. See Figure 6-99.



**Jackshaft/Pinion Gear Components**

**Figure 6-99**

33. Remove the motor thrust bearing assembly, swashplate kit and cradle bearings from the housing and inspect for unusual wear or damage. See Figure 6-100.



**Swashplate Kit and Thrust Bearing Assembly**

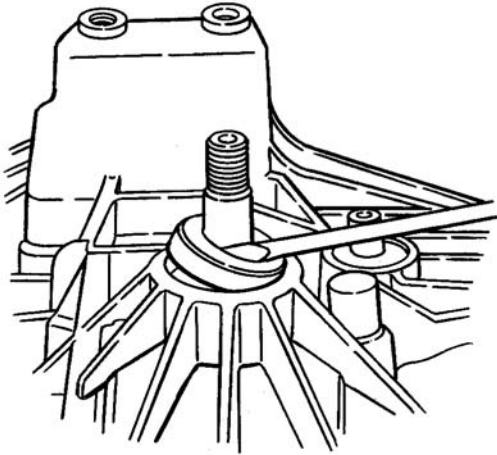
**Figure 6-100**

34. Remove the slot guide block from the displacement control shaft.

35. Remove the bypass actuator from the housing.

36. Reposition the housing and remove the input shaft lip seal from the housing bore. A hook type tool may be used to pry the seal out. Care

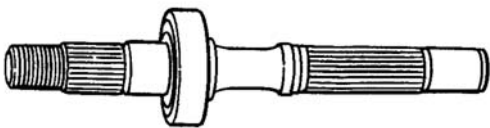
must be taken to avoid damage to the housing bore, shaft sealing surface or bearing. Once removed, the seal is not reusable. See Figure 6-101.



**Remove Input Shaft Lip Seal**

**Figure 6-101**

37. Remove the input shaft bearing retaining ring.
38. Remove the pump input shaft assembly from the housing.
39. Inspect the shaft and bearing for unusual wear or damage. See Figure 6-102.



**Pump Input Shaft Assembly**

**Figure 6-102**

40. Reposition housing and remove the displacement control shaft and lip seal.
41. Inspect the housing for damage.

**Reconditioning and Replacement of Parts.**

1. All parts should be thoroughly cleaned in a suitable solvent. All sealant material **MUST** be removed from the housing halves prior to reassembly.
2. Inspect all parts for damage, nicks or unusual wear patterns. Replace all parts having unusual, excessive wear or discoloration.

3. Inspect the sealing surfaces, bearing surfaces, and shaft splines. Polish the sealing areas on the shafts if necessary. Replace any worn or damaged parts.
4. The running surfaces of the cylinder blocks **MUST** be flat and free from scratches. If scratches or wear are found on the running surface of the cylinder block or center section, polish or replace the parts. When polishing these surfaces, up to .0004 inch may be removed. If this is not sufficient to obtain a flat surface free of scratches, the part should be replaced.
5. Clean and lightly oil parts prior to assembly of the IHT.

**Assembly Procedures.**

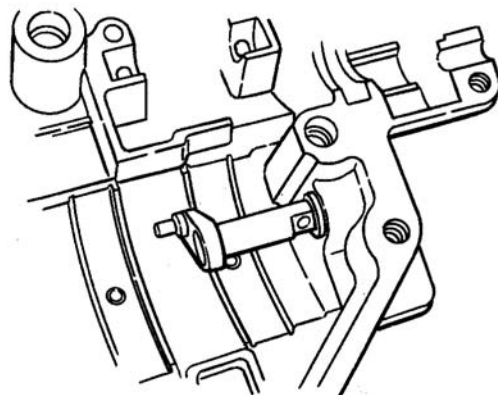
1. Be sure to torque all threaded parts to the recommended torque levels.
2. Replace all O-rings and shaft seals.



**CAUTION**

Most parts have critical high tolerance surfaces. Care must be exercised to prevent damage to these surfaces during assembly. Protect exposed surfaces, openings and ports from damage or foreign material.

3. Install the displacement control shaft. See Figure 6-103.

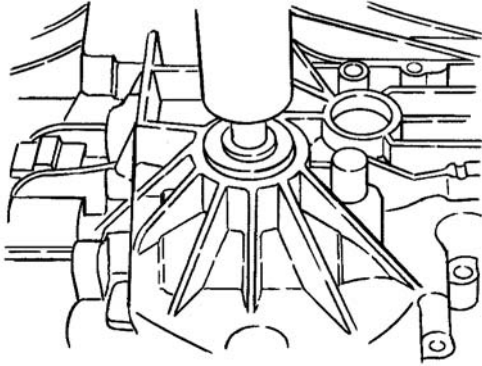


**Install Displacement Control Shaft**

**Figure 6-103**

4. Install the pump input shaft assembly and retaining ring into the housing. See Figure 6-104.

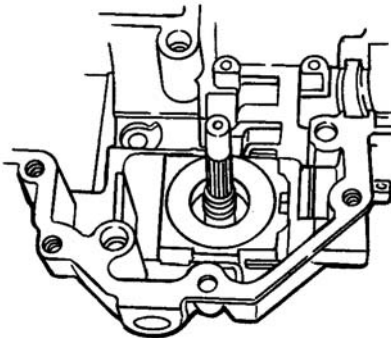




**Install Pump Shaft Assembly**

**Figure 6-104**

5. Install the pump shaft lip seal.
6. Reposition the upper housing and install the cradle bearings.
7. Install the slot guide block onto the displacement control shaft.
8. Install the swashplate assembly into the housing. The slot on the swashplate must engage the slot guide block on the displacement control shaft. Use a tool such as a screwdriver to hold the guide block in position while installing the swashplate. See Figure 6-105.



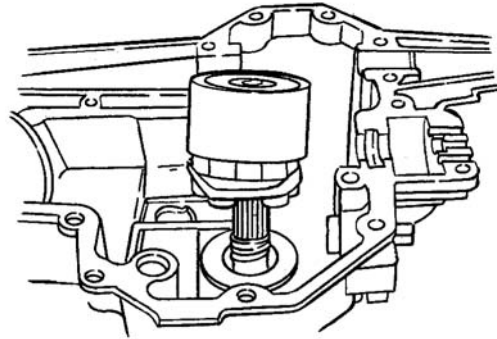
**Swashplate Installation**

**Figure 6-105**

9. Install the thrust washer and pump block spring onto the pump shaft.

**NOTE**

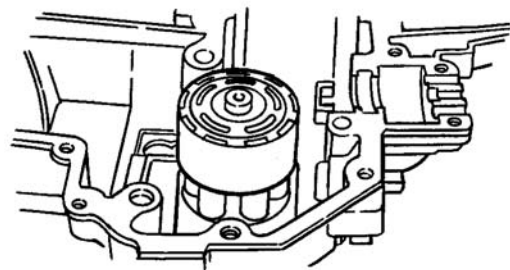
To simplify the installation of the pump block, wrap a rubber band snugly around the pistons. This is intended to hold the pistons in their bores as the block kit is handled during installation. See Figure 6-106.



**Cylinder Block Kit With Rubber Band**

**Figure 6-106**

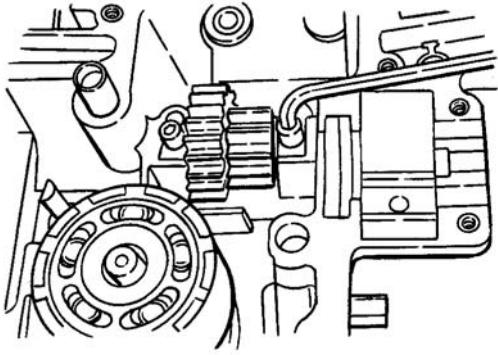
10. With the swashplate in the neutral (0 angle) position, lubricate the running surfaces and install the block kit onto the pump input shaft. Make sure the splines engage properly. See Figure 6-107.



**Install Pump Block Kit**

**Figure 6-107**

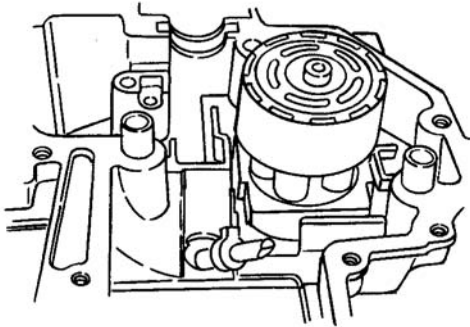
For 310-0750 Models Only: Install the pinion gear and washers onto the jackshaft. Install the jackshaft assembly into the housing and torque the bolts from 120-170 in-lbs. See Figure 6-108.



**310-0750 Jackshaft Assembly Installation**

**Figure 6-108**

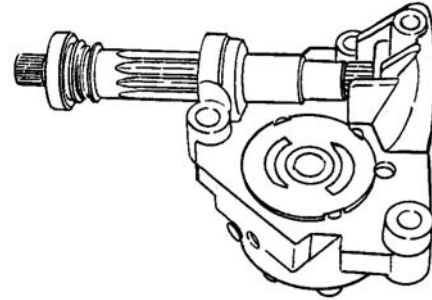
11. Install the aligning pins and the bypass actuator into the housing. See Figure 6-109.



**Install Aligning Pins and Bypass Actuator**

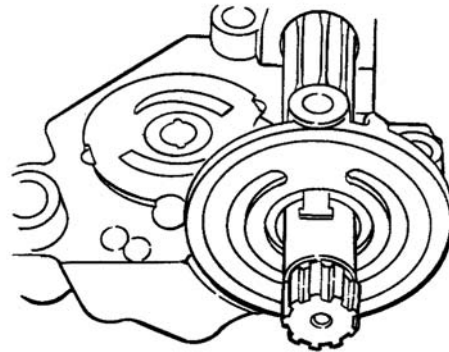
**Figure 6-109**

12. Install the washers and a new lip seal onto the motor shaft.
13. Install the motor shaft into the center section.
14. Install the bypass plate (small end first) into the center section.
15. Lubricate the running faces and install the motor block kit onto the motor shaft. See Figures 6-110, 6-111 and 6-112.



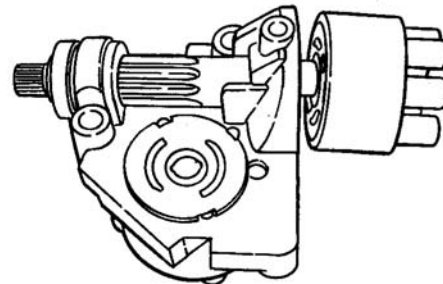
**Install Motor Shaft**

**Figure 6-110**



**Install Bypass Plate**

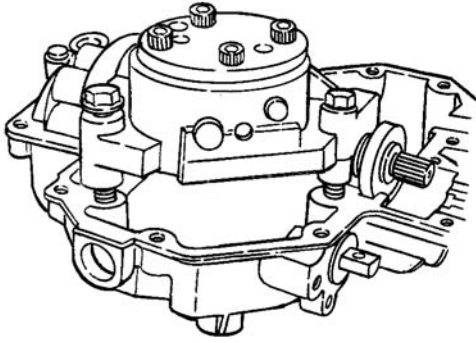
**Figure 6-111**



**Install Motor Block Kit**

**Figure 6-112**

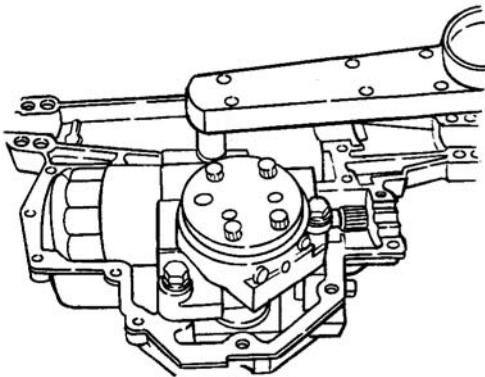
16. Position the washers and seal and install the center section assembly onto the aligning pins and pump input shaft. See Figure 6-113.



**Position Center Section Assembly**

**Figure 6-113**

17. Inspect the three assembly bolts into the center section and press center section down onto the aligning pins and pump input shaft until seated on mounting bosses. While holding the center section in position, torque the bolts evenly from 525-700 in-lbs. See Figure 6-114.



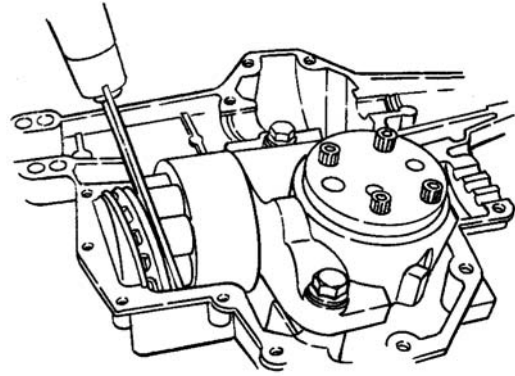
**Install Center Section Assembly**

**Figure 6-114**

18. Install the motor thrust bearing (with the thicker race towards the pistons) by compressing the piston springs and sliding the bearing assembly into place.

**→ NOTE**

The tool being shown is an example of what you will need to compress the pistons and allow the bearing to be installed. See Figure 6-115.



**Install Motor Thrust Bearing**

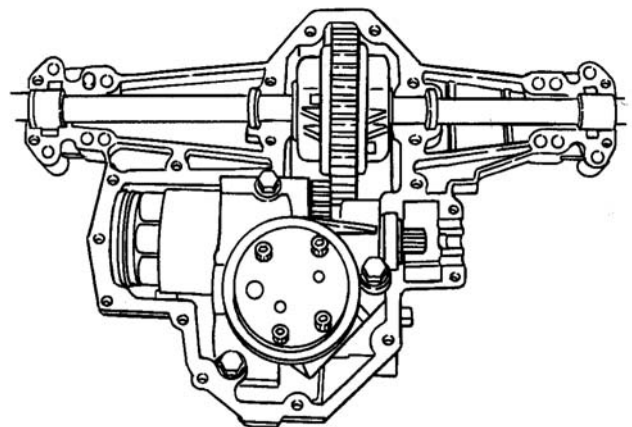
**Figure 6-115**

19. Fill the axle pockets of the upper housing with Rykon Premium grease (inside of bearing location).

**→ NOTE**

This grease is not compatible with all grease types.

20. Do not overfill, and wipe off any excess grease or sealant will not cure properly.
21. Install the washers and seals onto the differential / axle assembly and align them for installation.
22. Install the differential/axle assembly into the housing. See Figure 6-116.

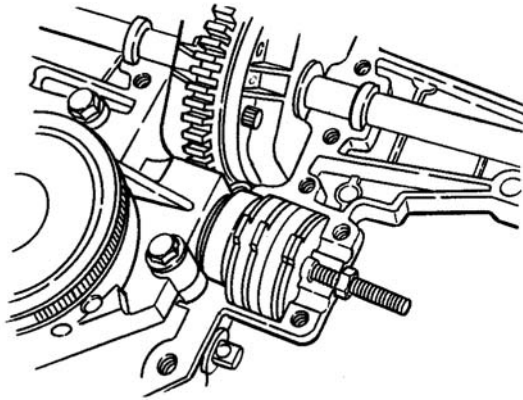


**Install Differential/Axle Assembly**

**Figure 6-116**

23. Install a new filter onto the center section/ check valve plate.

24. Install the rotors and stators. Install a stator, then a rotor (hub to inside), then a stator, then a rotor (hub to inside), then two stators.
25. Install the brake bolt (with nut) into the upper housing. See Figure 6-117.



**Install Brake Components**

**Figure 6-117**

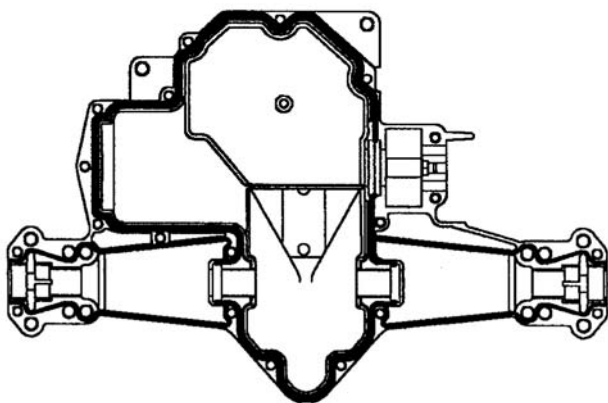
26. Fixture the lower housing and apply the sealant as shown in the following two examples.

**NOTE**

The following drawings may not appear the same as the factory sealant application, but are the recommended patterns. Apply sparingly.

**NOTE**

Sealant must be of good quality, oil and heat resistant. See Figure 6-118.



**310-0500 Sealant Application**

**Figure 6-118**

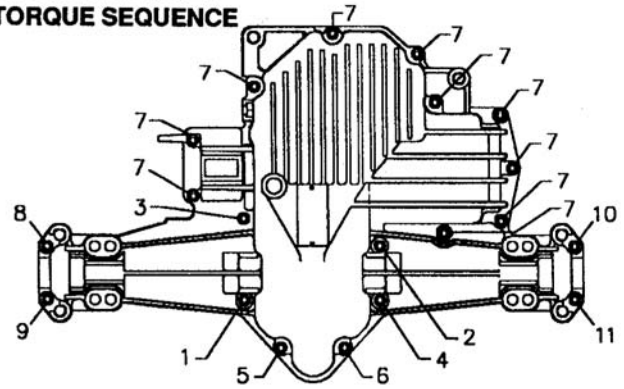
27. Position the lower housing onto the upper housing and secure with assembly bolts.

Torque the bolts from 135 to 165 in-lbs following the patterns illustrated below.

**NOTE**

The group of bolts around the front of the housings have the same sequence number because they are installed simultaneously at our factory, the order in which you torque them should not be important. See Figure 6-119 and 6-120.

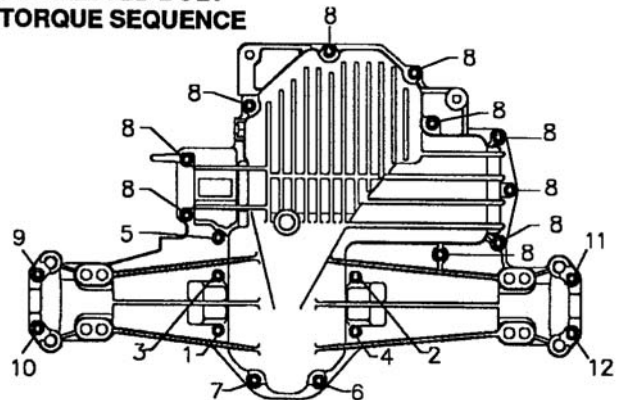
**SUGGESTED BOLT TORQUE SEQUENCE**



**310-0500 Bolt Torque Sequence**

**Figure 6-119**

**SUGGESTED BOLT TORQUE SEQUENCE**



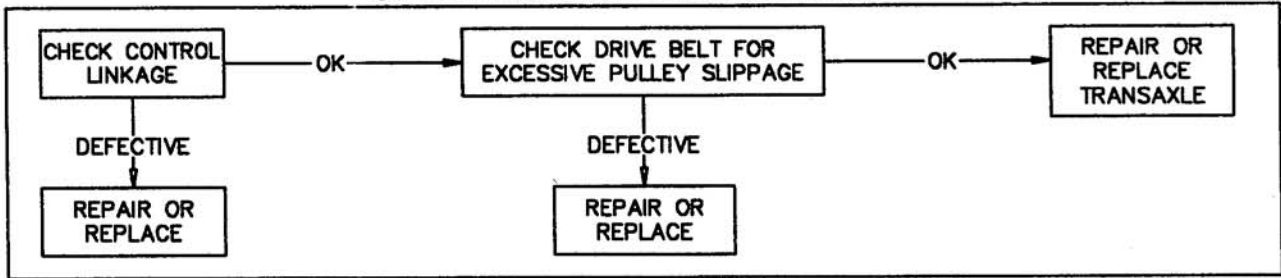
**310-0750 Bolt Torque Sequence**

**Figure 6-120**

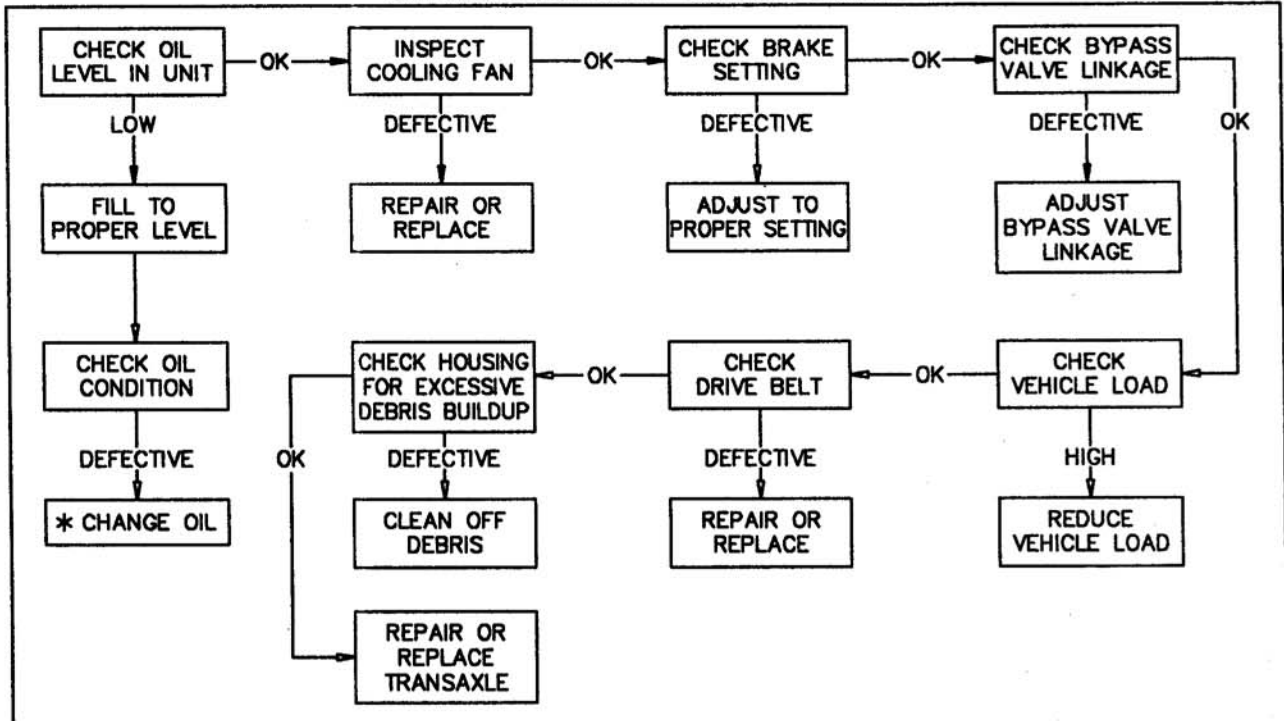
28. After torquing all bolts, wipe off any excess sealant from the seam of the housings.
29. Reposition the transaxle assembly and check the bypass actuator and axle shafts for freedom of movement. The axle shafts should not lock up but may be tight, while the bypass actuator must rotate freely. Continued on page 6-48.

# TROUBLESHOOTING DIAGRAM 310-0500/0750 IHT

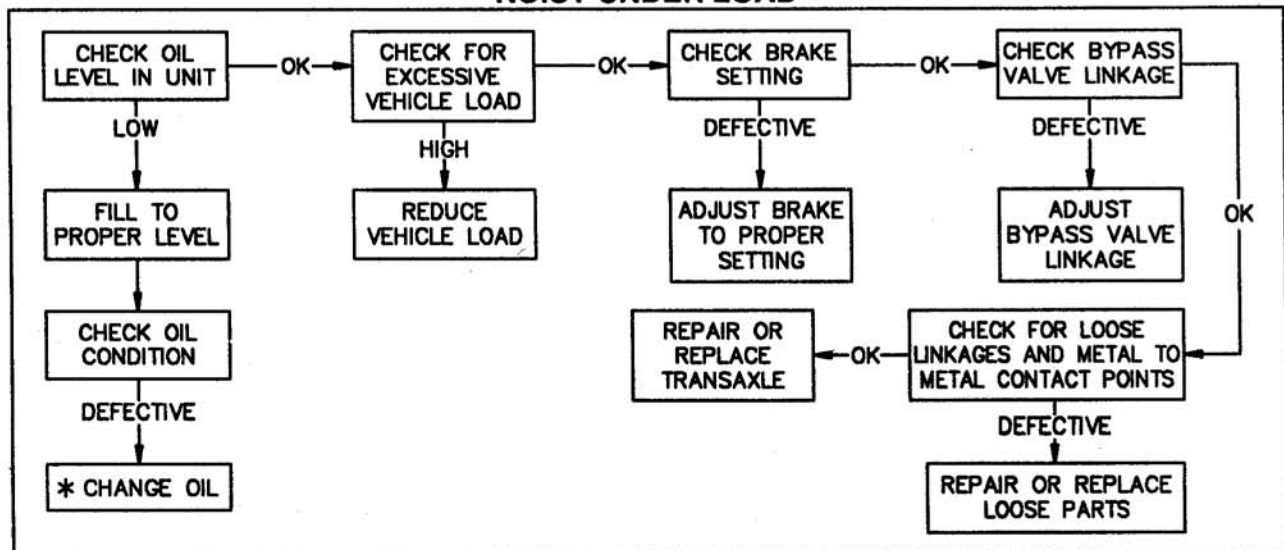
## OPERATES IN ONE DIRECTION ONLY



## OPERATING HOT / LOSING POWER



## NOISY UNDER LOAD



\* WILL REQUIRE TRANSAXLE REMOVAL

## TROUBLESHOOTING CHART 310-0500/0750 IHT

**WARNING!!!**  
**THE VEHICLE SHOULD BE ON LEVEL GROUND AND**  
**THE ENGINE DISABLED BEFORE PERFORMING ANY ADJUSTMENTS**

### SYMPTOM - OPERATES IN ONE DIRECTION ONLY

#### POSSIBLE CAUSE

- Inspect control linkage
- Inspect drive belt & pulleys

#### CORRECTIVE ACTION

- Repair or replace
- Repair or replace

### SYMPTOM - NOISY

#### POSSIBLE CAUSE

- Check oil level & condition
- Check for excessive loading
- Check brake setting
- Check for loose parts
- Check bypass valve linkage operation

#### CORRECTIVE ACTION

- Fill to proper level or change oil
- Reduce vehicle loading
- Adjust brake to proper setting
- Repair or replace loose parts
- Repair or replace linkage

### SYMPTOM - LOW POWER

#### POSSIBLE CAUSE

- Check engine RPM
- Check drive belt & pulleys
- Check oil level & condition
- Check for excessive loading
- Check brake setting
- Check for loose parts
- Check bypass valve linkage operation

#### CORRECTIVE ACTION

- Adjust to correct setting
- Repair or replace
- Fill to proper level or change oil
- Reduce vehicle loading
- Adjust brake to proper setting
- Repair or replace loose parts
- Repair or replace linkage

### SYMPTOM - OPERATING HOT

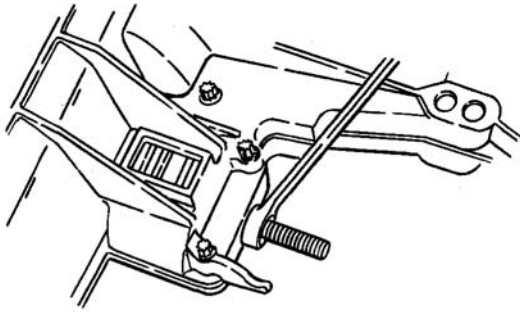
#### POSSIBLE CAUSE

- Check for debris buildup
- Check oil level & condition
- Check for excessive loading
- Check brake setting

#### CORRECTIVE ACTION

- Clean off debris
- Fill to proper level or change oil
- Reduce vehicle loading
- Adjust brake to proper setting

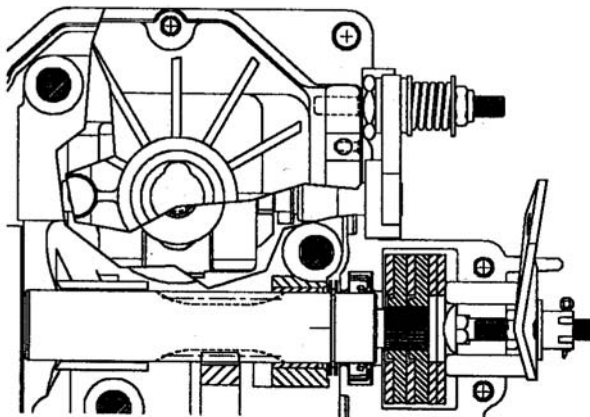
30. Torque the nut on the brake bolt from 120-185 in-lbs. See Figure 6-121.



**Tighten Brake Bolt Nut**

**Figure 6-121**

31. Install a new lip seal on the displacement control shaft and bypass actuator. a
32. Install the brake pins and brake arm.
33. Install the washer and adjustment nut.
34. Adjust the brake clearance.
35. Refer to paragraph 10-4.5 before installing the control arm and friction pack.

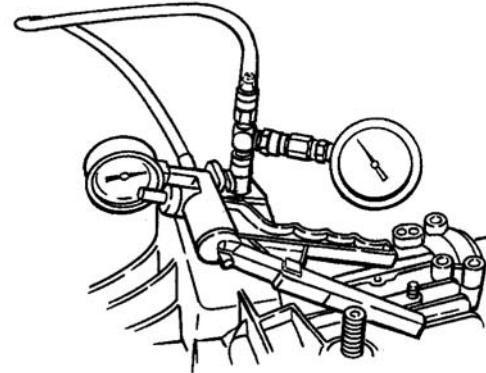


**Brake and Control Arm Components**

**Figure 6-122**

36. Install the bypass actuator arm and retaining ring. Use care to avoid over extending the retaining ring.
37. Prior to adding oil to the IHT it is recommended that you test for leaks. This may be performed with a small hand pump or by using com-

pressed air and a regulator. Do not allow more than 10 PSI to be applied or seal damage may occur. To locate a leak, apply a soap mixture around the housing seam and at all lip seals. Do not submerge unit or the brake will be damaged. See Figure 6-123.



**Test for Leaks**

**Figure 6-123**

#### **Oil Fill & Start-Up Procedures.**

1. Fill the IHT with a 20W-50 engine oil. The correct volume for fill should be 2-1/2 quarts (80 ounces) for both the 310-0500 and the 310-0750
2. It is recommended that the unit be purged prior to installing into the vehicle frame. The following is the suggested purging procedures for repairing transaxles.
  - a. Spin the input shaft in a clockwise direction at 1000-1500 RPM. This may be performed in a drill press (or equivalent).
  - b. Engage (actuate) the bypass.
  - c. Stroke the control lever forward for five seconds and then reverse for five seconds. Do this three times in each direction.
  - d. Return the control lever to neutral.
  - e. Disengage the bypass.
  - f. Stroke the control lever forward for five seconds and then reverse for five seconds. Do this three times in each direction.

**➔ NOTE**

It may be necessary to repeat these steps in the vehicle to fully purge the IHT.

3. Check the oil level after fully purging the unit of air. It should be between 1.75 and 2.0

inches from the top of the housing for the 310-0500, and between 1.25 and 1.62 inches from the top of the housing for the 310-0750.

4. After installing the IHT, make sure all linkages and actuators are functioning properly. Refer to the Troubleshooting Section.

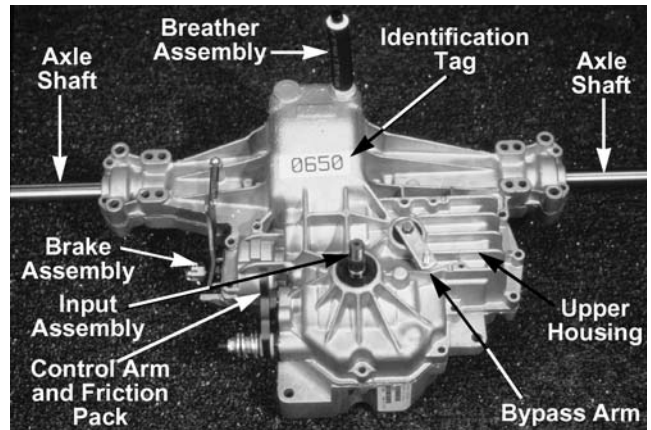
**Hydro-Gear's (Integrated Hydrostatic Transaxle).**

1. It is designed for use on consumer lawn and yard tractors. See Figure 6-124.



**Figure 6-124**

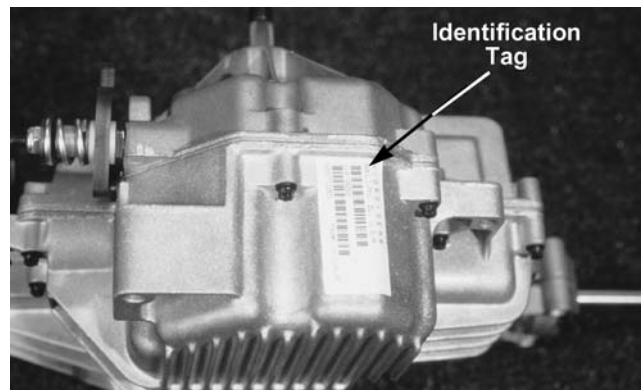
2. External components of the IHT consist of:
  - A. Bypass arm
  - B. Input assembly
  - C. Identification tag
  - D. Control arm and friction pack
  - F. Brake assembly
  - G. Breather assembly
  - H. Axle shafts
  - I. Upper housing. See Figure 6-125.



**Figure 6-125**

3. Shown here is Hydro-Gear's identification tag. It provides the following essential information:

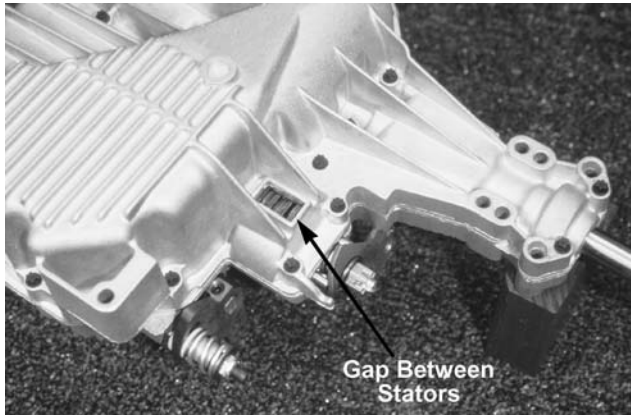
- A. Customer model number.
- B. Hydro-Gear model number (starts on serial date "6275" (10 Oct. 96).
- C. Serial number. See Figure 6-126.



**Figure 6-126**

4. The brake setting may be measured through the brake assembly window of the lower housing. To measure the brake setting insert a feeler gauge between the outside two stators of the brake pack. A gap between the two stators as shown. See Figure 6-126 and Figure 6-127.



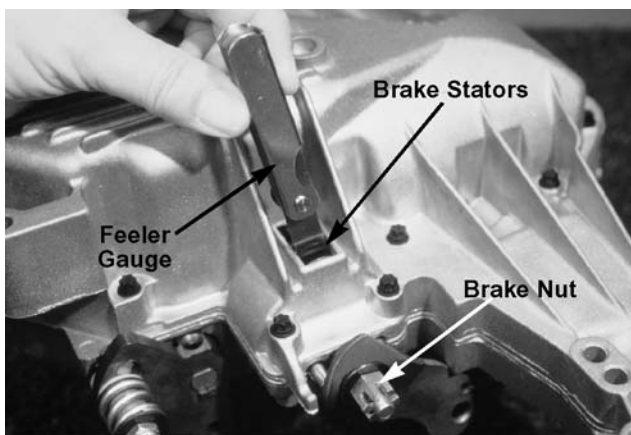


**Figure 6-127**

5. To set the brake you will have to remove the cotter pin from the brake bolt, and then tighten or loosen the brake nut until the specified setting is reached. The feeler gauge inserted between the two outside stators

**➡ NOTE**

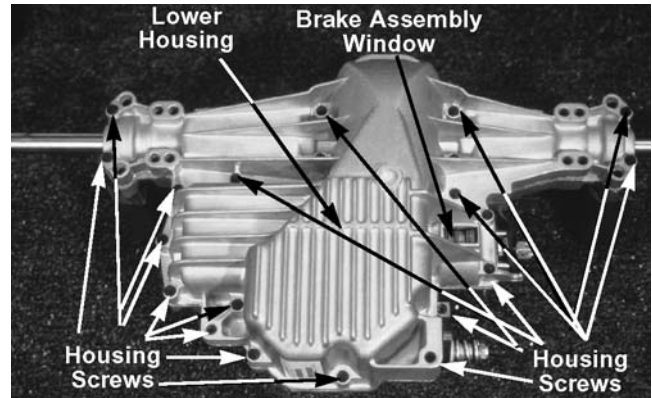
If the correct setting falls between the flats of the brake nut you must loosen the brake nut to the next flat. Never set the brake tighter than the specified setting! See Figure 6-128.



**Figure 6-128**

6. External components of the IHT consist of
  - A. Lower housing
  - B. Housing screws
  - C. Brake assembly window

See Figure 6-129.

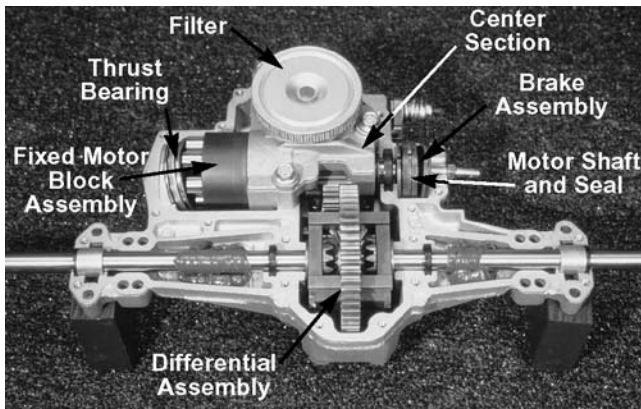


**Figure 6-129**

7. After the removal of the lower housing you will be able to identify these components:

- A. Filter
- B. Center section
  - C. Brake assembly
    - a. Brake bolt and nut
    - b. Two stators (rounded sides together)
    - c. Rotor, stator, rotor, and stator
  - D. Motor shaft and seal
  - E. Fixed motor block assembly
    - a. Motor block
    - b. Pistons
  - F. Thrust bearing
    - a. Thick race towards the center of the unit
- G. Differential assembly
  - a. Outer wiper seals
  - b. Axle sleeve bearings
  - c. Inner seals
  - d. Gear set
  - e. Axle shafts

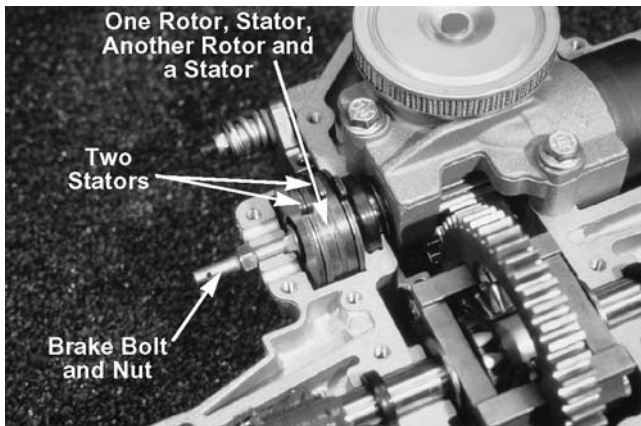
See Figure 6-130.



**Figure 6-130**

8. The internal brake assembly consists of:
  - A. Brake bolt and nut
  - B. Two stators (rounded sides together)
  - C. One rotor, a stator, another rotor, and finally a stator

See Figure 6-131.

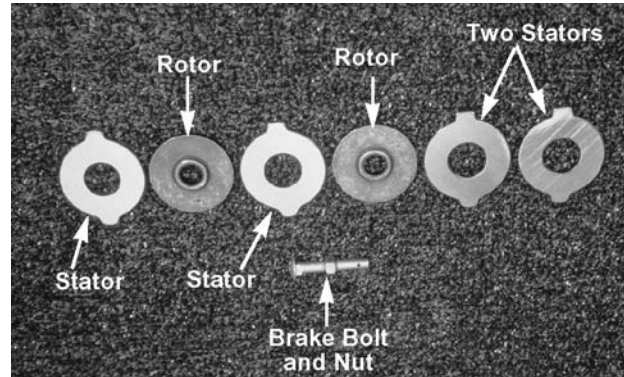


**Figure 6-131**

9. Once the brake assembly is disassembled thoroughly inspect each part for excessive wear or damage.
  - A. Brake bolt and nut
  - B. Two stators (rounded sides together)
  - C. Rotor
  - D. Stator
  - E. Rotor
  - F. Stator

**NOTE**

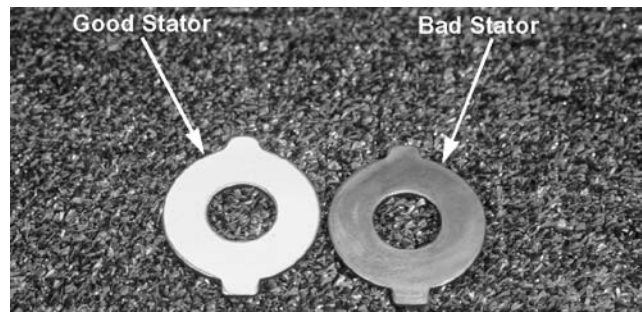
Bluing of the rotors and stators is caused by excessive heat in the brake assembly. This defect may be caused by binding vehicle brake linkage, improper brake setting. See Figure 6-132.



**Figure 6-132**

10. The correct brake setting is always a major concern.
11. Here is a good stator versus a bad stator (over-heated).

This defect may be caused by binding vehicle brake linkage, improper brake setting. See Figure 6-133.



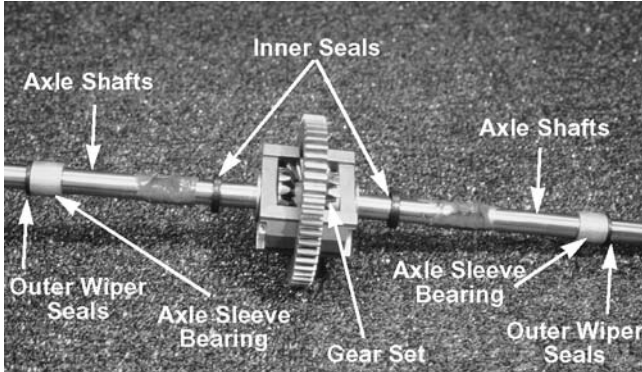
**Figure 6-133**

12. After removal of the differential assembly thoroughly inspect each part for excessive wear or damage.
  - A. Outer wiper seals
  - B. Axle sleeve bearings
  - C. Inner seals
  - D. Gear set (rotate axle shaft and inspect the planetary gears of the differential)

## E. Axle Shafts

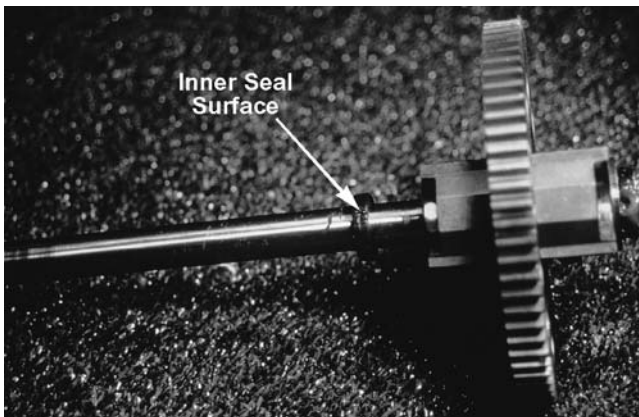


Axle shaft seals will always be replaced when the IHT case halves are separated. See Figure 6-134.



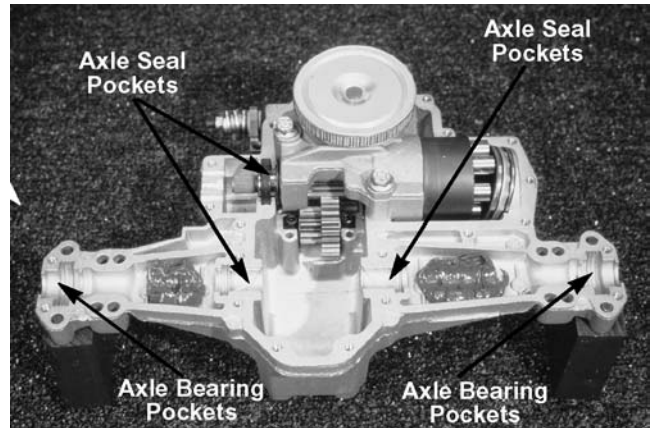
**Figure 6-134**

13. The axle shaft has sealant on the inner seal surface area. The sealant on the axle shaft will cause the seal to leak oil. Oil normally will leak out of the axle horn area. See Figure 6-135.



**Figure 6-135**

14. With the differential assembly removed inspect the upper and lower housings for excessive wear or damage.
  - A. Axle seal pockets (check the middle of the seal pockets for a good crush ring)
  - B. Axle bearing pockets
  - C. Grease (check for any type of contamination) See Figure 6-136.



**Figure 6-136**

15. Insure the two washers on the motor shaft are in the correct position. (Located between the upper housing and the center section.) See Figure 6-137.

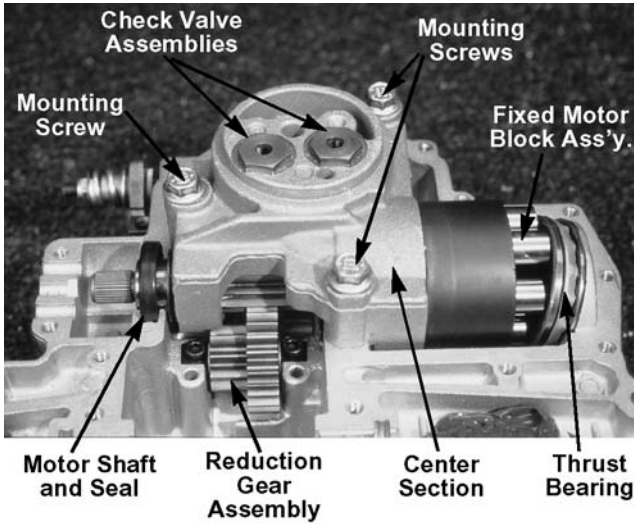


**Figure 6-137**

16. Here we can identify the component parts:

- A. Center section
- B. Three center section mounting screws
- C. Motor shaft and seal
- D. Fixed motor block assembly
  - a. Motor block
  - b. Pistons
- E. Thrust bearing
  - a. Thick race towards the center of the unit
- F. Reduction gear assembly

- G. Check valve assemblies (insure each check valve's bleed orifice is open) See Figure 6-138.



**Figure 6-138**

- 17. After removal of the thrust bearing inspect it for excessive wear or damage.

- A. Thick race (always mates to the rotating group)
- B. Caged ball bearing assembly
- C. Thin race (never mates to the rotating group)

See Figure 6-139.



**Figure 6-139**

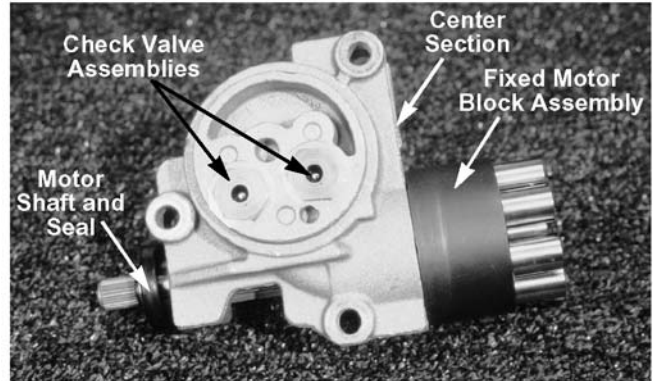
- 18. Shown here is the center section assembly removed from the housing. Conduct an inspection of each part.

- A. Center section
- B. Motor shaft and seal
  - a. Motor shaft seal should be replaced each time the center section assembly is removed from the housing.

- C. Fixed motor block assembly

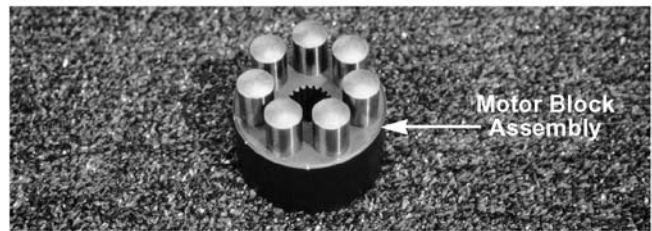
- a. Motor block
- b. Pistons

- D. Check valve assemblies (insure each check valve's bleed orifice is open) See Figure 6-140.



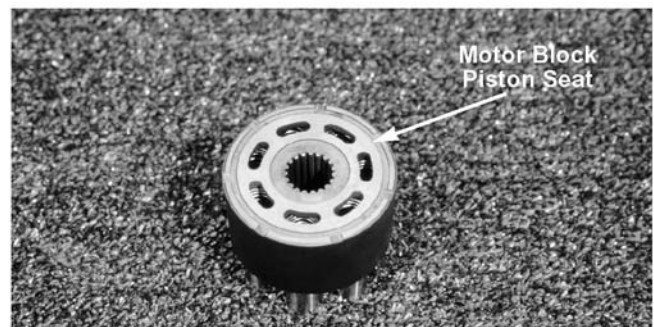
**Figure 6-140**

- 19. Inspect the motor block assembly. See Figure 6-141.



**Figure 6-141**

- 20. Inspect the motor block, piston seat areas, running surface, and splines for excessive wear or damage. See Figure 6-142



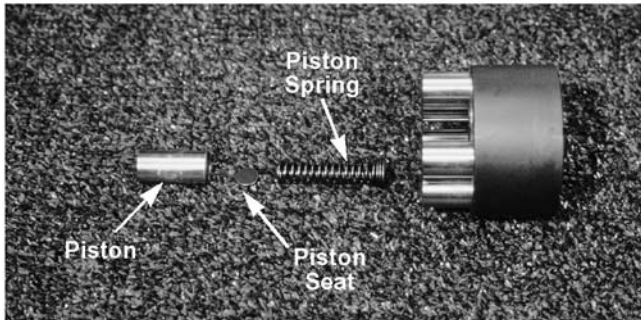
**Figure 6-142**

- 21. Insure each piston moves smoothly in each piston bore of the pump block. Also inspect:

- A. Piston spring

- B. Piston seat
- C. Piston

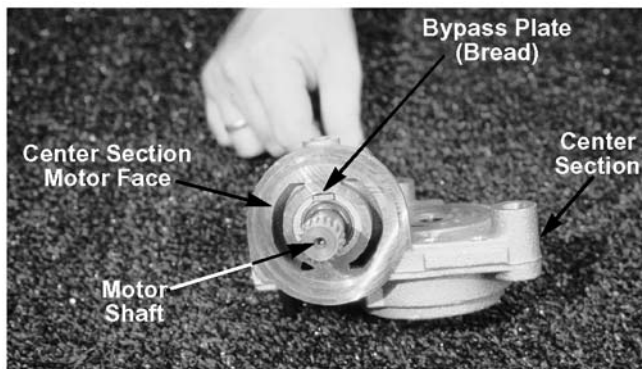
See Figure 6-143.



**Figure 6-143**

22. Inspect the center section motor face and inspect each of these parts / areas:
- A. Center section
  - B. Bypass plate (bread)
  - C. Motor shaft
  - D. Center section motor face

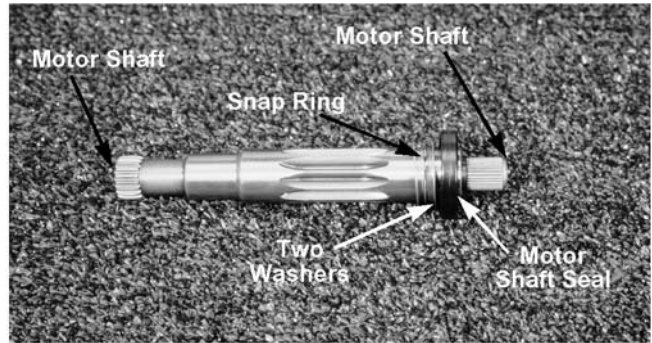
See Figure 6-144.



**Figure 6-144**

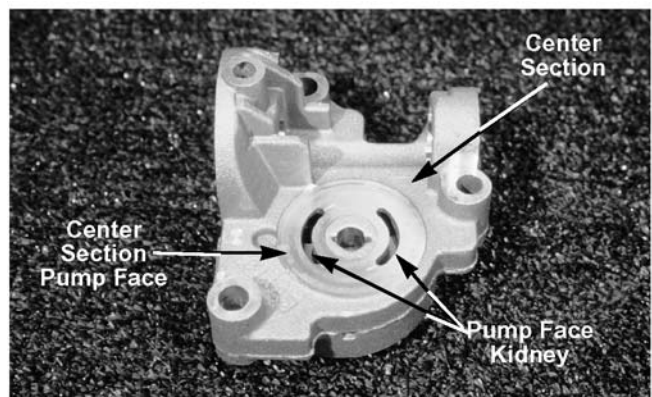
23. Once the motor shaft is removed from the center section you can inspect each of these areas for excessive wear or damage:
- A. Motor shaft seal (always replace with a new seal)
  - B. Two washers
  - C. Snap ring

- D. Motor shaft (splines, gear teeth) See Figure 6-145.



**Figure 6-145**

24. Inspect the center section pump and identify and inspect each of these parts/ areas:
- A. Center section
  - B. Bypass actuator bore
  - C. Input shaft bore
  - D. Center section pump face
  - F. Pump face kidney (each kidney port has a passage through the center section to the motor face kidneys See Figure 6-146).

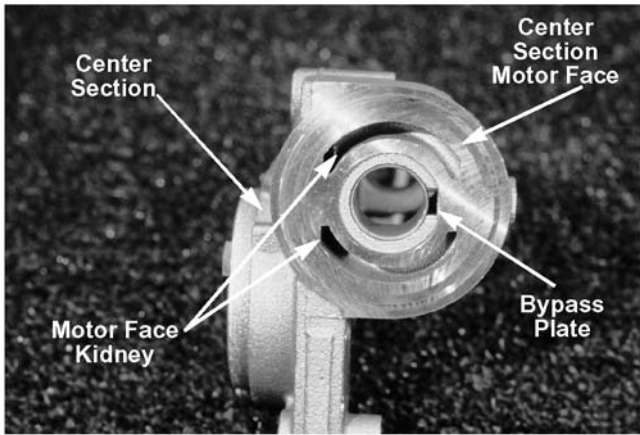


**Figure 6-146**

25. Here we have another view of the center section motor face and inspect each of these parts/ areas:
- A. Center section
  - B. Bypass plate (bread)
  - C. Center section motor face



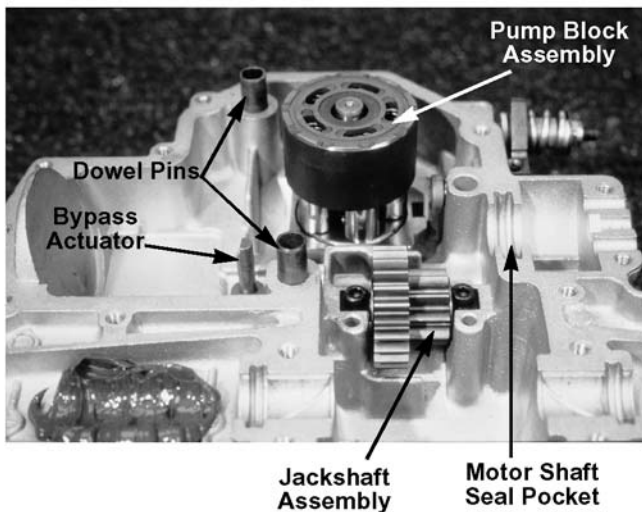
- D. Motor face kidney (each kidney port has a passage through the center section to the pump face kidneys) See Figure 6-147.



**Figure 6-147**

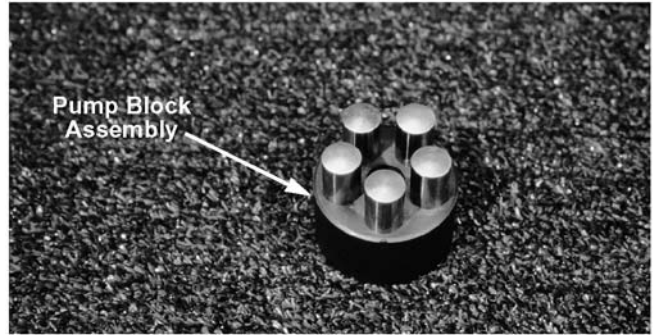
- 26. Once the center section is removed you can identify these components:

- A. Pump block assembly
- B. Bypass actuator
- C. Dowel pins
- D. Jackshaft assembly
- E. Motor shaft seal pocket (check the middle of the seal pockets for a good crush ring) See Figure 6-148.



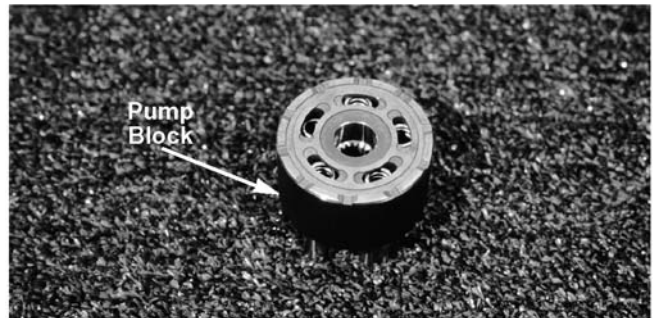
**Figure 6-148**

- 27. Shown is the pump block assembly. See Figure 6-149.



**Figure 6-149**

- 28. Inspect the pump block, piston seat areas, running surface, and splines for excessive wear or damage. See figure 6-150.

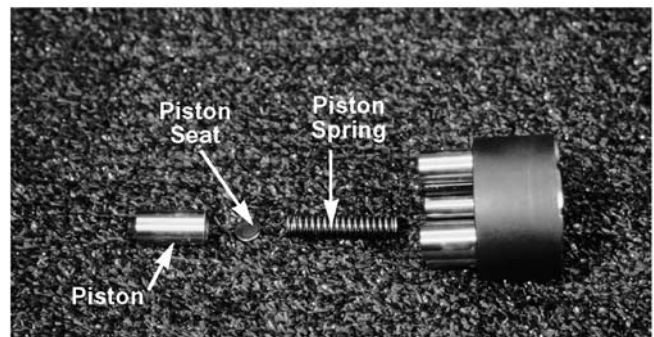


**Figure 6-150**

- 29. Insure each piston moves smoothly in each piston bore of the pump block. Also inspect:

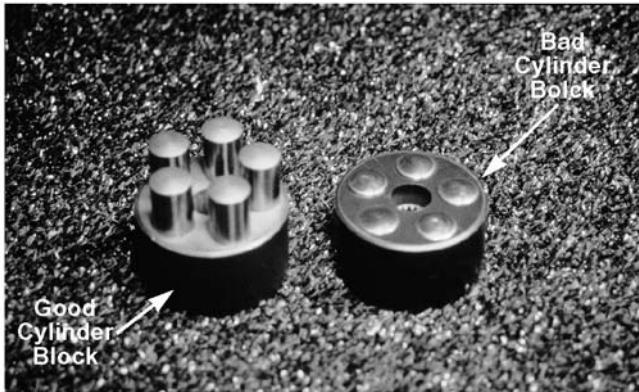
- A. Piston spring
- B. Piston seat
- C. Piston

See Figure 6-151.



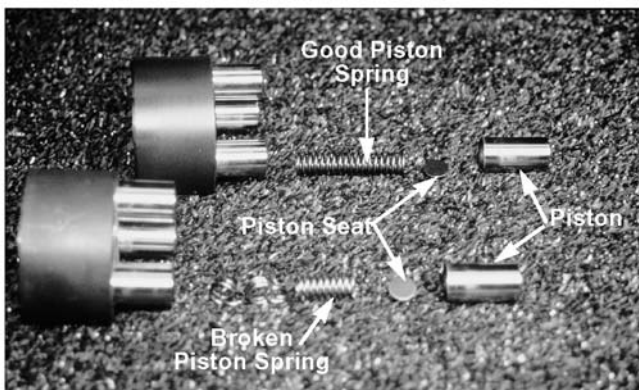
**Figure 6-151**

30. Shown here is good cylinder block assembly versus a bad cylinder block assembly. The bad cylinder block assembly has been damaged by contamination. All of the piston spring have seized to the cylinder block. This will cause the transmission to display low or no power symptoms. See Figure 6-152



**Figure 6-152**

31. Shown here is another example of a good cylinder block assembly versus a bad cylinder block assembly. The bad cylinder block assembly has a broken piston spring. This will cause the transmission to display low or no power symptoms. The piston spring will probably damage the running surface between the valve plate and the cylinder block assembly. See Figure 6-153.



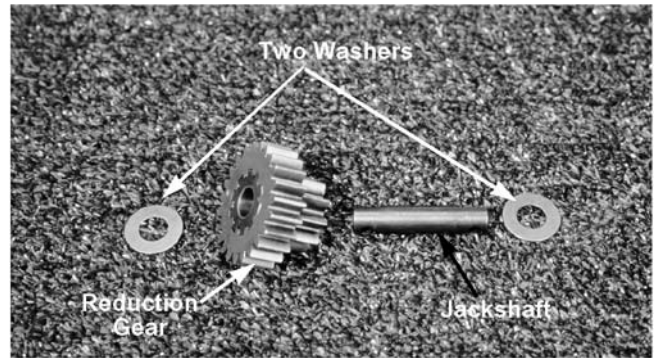
**Figure 6-153**

32. Inspect the jackshaft assembly for excessive wear or damage.

- A. Two washers
- B. Jackshaft

C. Reduction gear

See Figure 6-154.

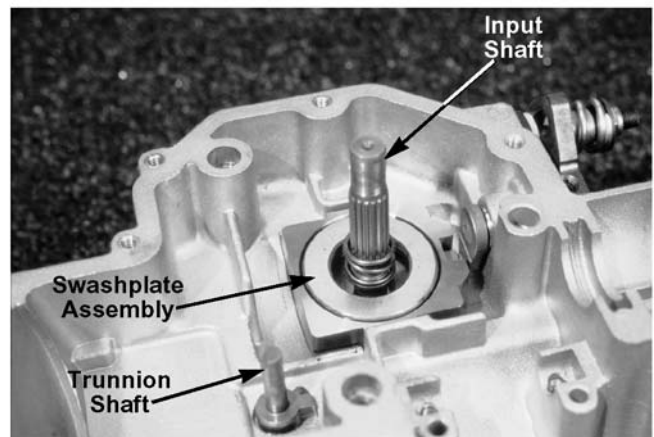


**Figure 6-154**

33. Parts still installed in the upper housing are:

- A. Input shaft
- B. Trunnion shaft
- C. Bypass actuator
- D. Swashplate assembly

See Figure 6-155.

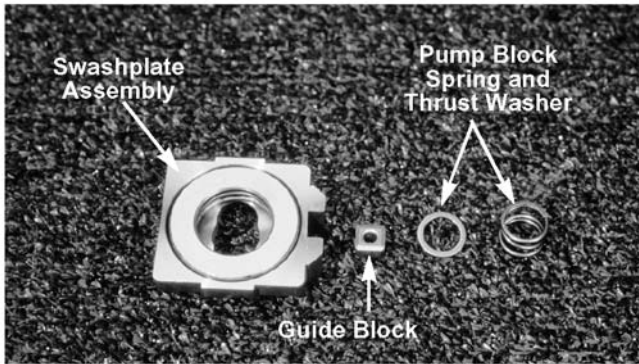


**Figure 6-155**

34. After the swashplate assembly is removed from the upper housing inspect all parts for excessive wear or damage.

- A. Pump block spring and thrust washer
- B. Guide block
- C. Swashplate assembly

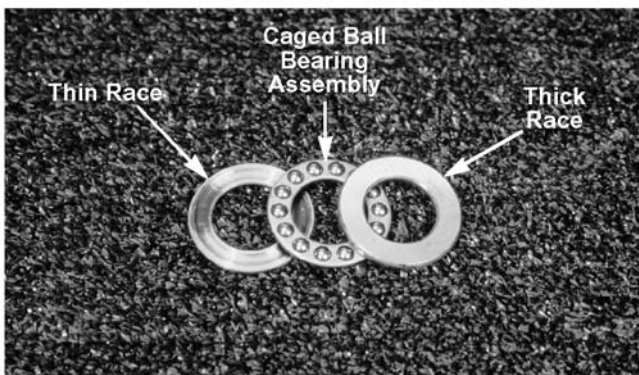
See Figure 6-156.



**Figure 6-156**

35. After removal of the thrust bearing from the swashplate inspect it for excessive wear or damage.
- A. Thick race (always mates to the rotating group)
  - B. Caged ball bearing assembly
  - C. Thin race (never mates to the rotating group)

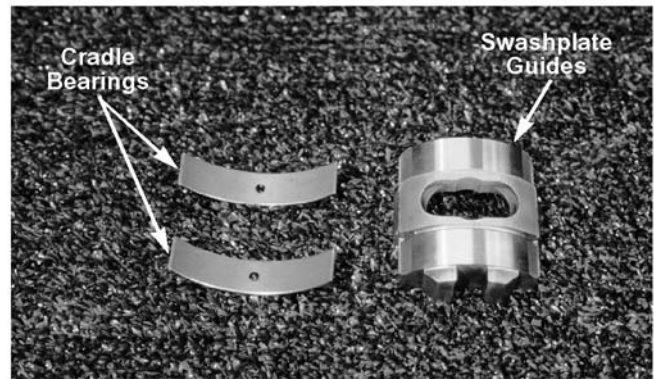
See Figure 6-157.



**Figure 6-157**

36. Remove and inspect the two cradle bearings and the swashplate for excessive wear or damage.
- A. Swashplate guides
  - B. Cradle bearings

See Figure 6-158.



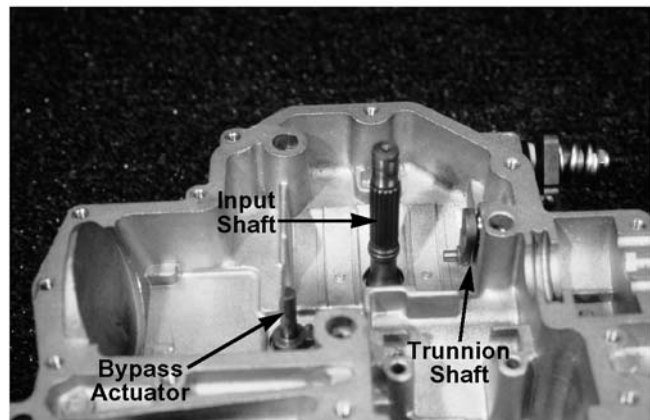
**Figure 6-158**

37. Again we can identify these parts:

- A. Bypass actuator
- B. Trunnion shaft
- C. Input shaft

Also we can inspect the upper housing dowel pin holes for excessive wear or damage.

See Figure 6-159.

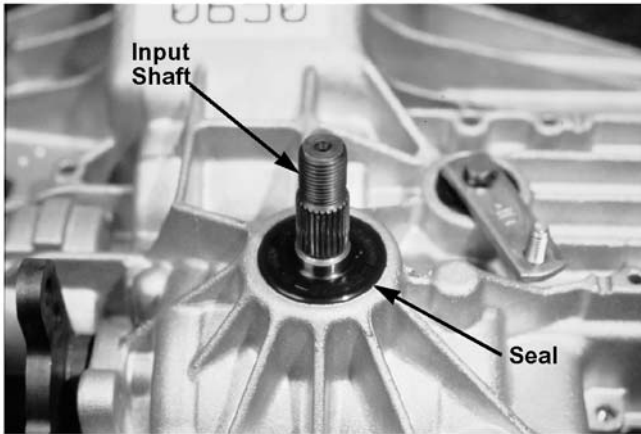


**Figure 6-159**

38. Here on the external side of the upper housing we can identify the input shaft and seal.

See figure 6-160.



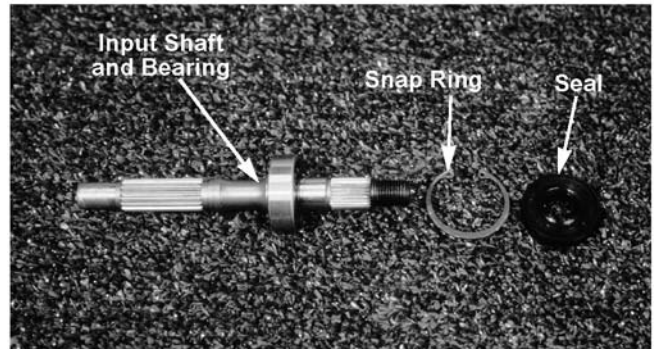


**Figure 6-160**

39. Once the input assembly is removed, disassemble and inspect each part for excessive wear or damage.

- A. Input shaft seal (always replace with a new seal)
- B. Snap ring
- C. Input shaft and bearing

See Figure 6-161.



**Figure 6-161**

# LAWN TRACTORS

## LAWN TRACTORS 300 AND 400 SERIES.

This subsection contains specific information applicable to the 300 and 400 lawn tractors only.

1. The principle of this drive system is basically the same as discussed earlier in the operation on the variable speed pulley.
2. The drive system combines our single speed transaxle with a variable speed pulley.
3. The variable speed pulley pivots back and forth, and a spring loaded idler pulley is positioned between the variable speed pulley and transaxle pulley to maintain this tension.

### ➔ NOTE

There may be times when the customer will not be able to obtain a full speed range. This may be caused by the brackets occasionally hang-

ing up after substantial use. You will need to disassemble the variable speed bracket assembly and the variable speed torque bracket assembly, take out the nylon bushings, clean shafts, grease and reinstall. Perform a variable speed control adjustment.

### ➔ NOTE

There have been a few instances reported where the drive belt flips or rolls off the variable speed pulley on 1992 300 and 400 Series riders. This is due to misalignment. To correct this problem, add a .250 washer above the variable speed bracket assembly hub using part number 736-0235. This will align the variable speed pulley with the engine and transmission pulleys. See Figure 7-1.

Install spacer as follows:

1. Lower deck to lowest cutting position.

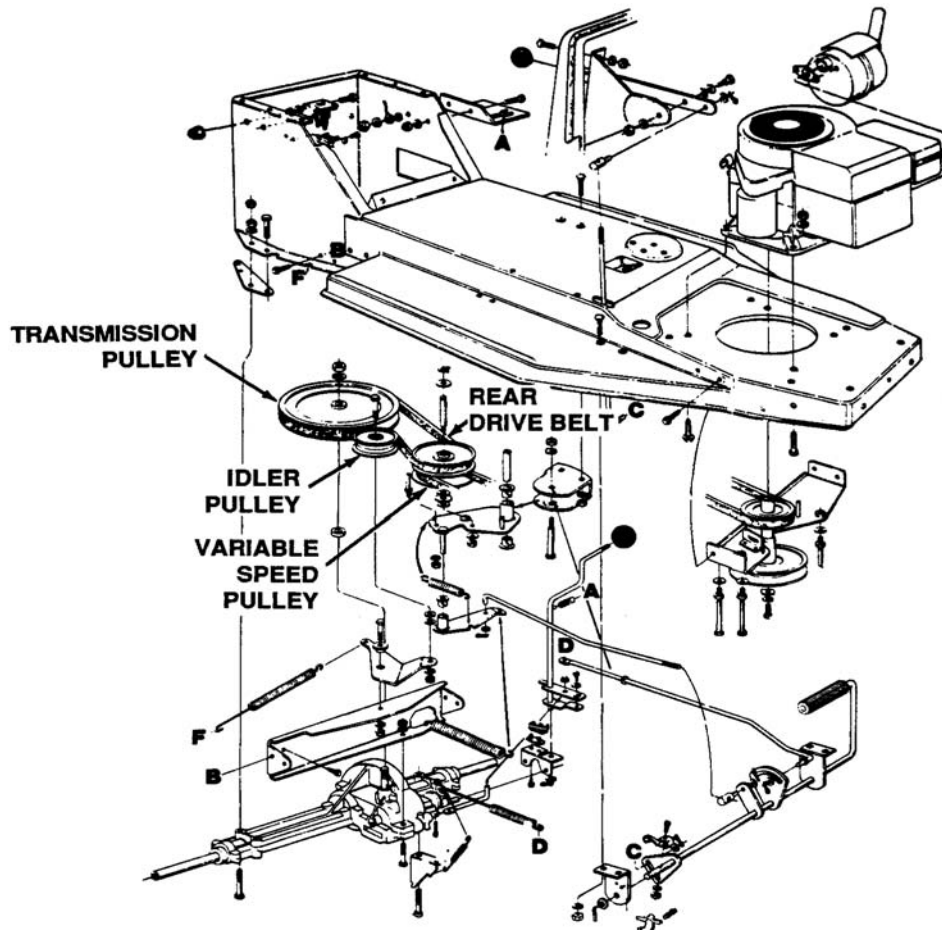


Figure 7-1. Variable Speed Drive System

2. Remove spring from variable speed torque bracket assembly.
3. Remove 4 inch bolt that secures the variable speed bracket assembly.
4. Insert spacer between bracket and frame.
5. Reassemble bolt and spring.

**➔ NOTE**

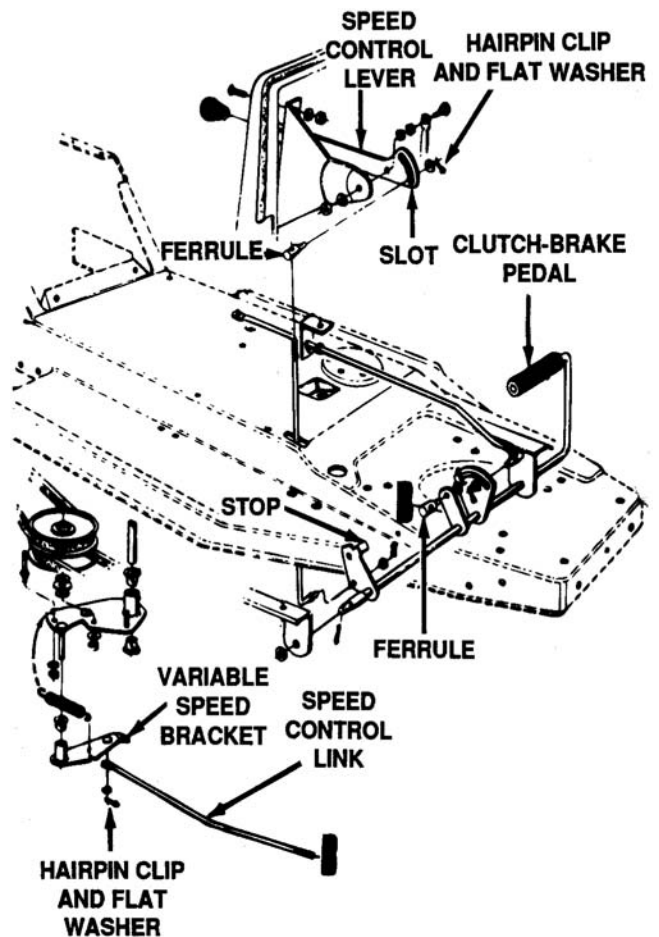
On 1992, the idler bracket has two holes that secure the idler pulley. The inner hole is used for the 600 Series rider; the outer hole is used on the 300 and 400 Series riders.

**➔ NOTE**

When operating the unit initially or after replacing the belts, there will be little difference between the highest two speeds until after the belts have gone through a break-in period and have seated themselves into the pulleys.

See Figure 7-2 and adjust the speed control lever as follows:

1. Place the shift lever in Neutral position.
2. Start the engine.
3. Place the speed control lever in high speed position.
4. Release the clutch-brake pedal completely, then slowly depress the pedal all the way (to disengage position). Hold the pedal in this position.
5. Turn the engine off.
6. After engine stops completely, release the clutch-brake pedal.
7. Disconnect the speed control link from the variable speed bracket by removing the cotter pin and flat washer below the variable speed bracket.
8. Depress the clutch-brake pedal forward until the stop on the clutch-brake pedal assembly hits solidly against the underside of the frame.
9. Remove the hairpin clip and flat washer from the rod attached to the back of the speed control lever.



**Figure 7-2. Speed Control Adjustment**

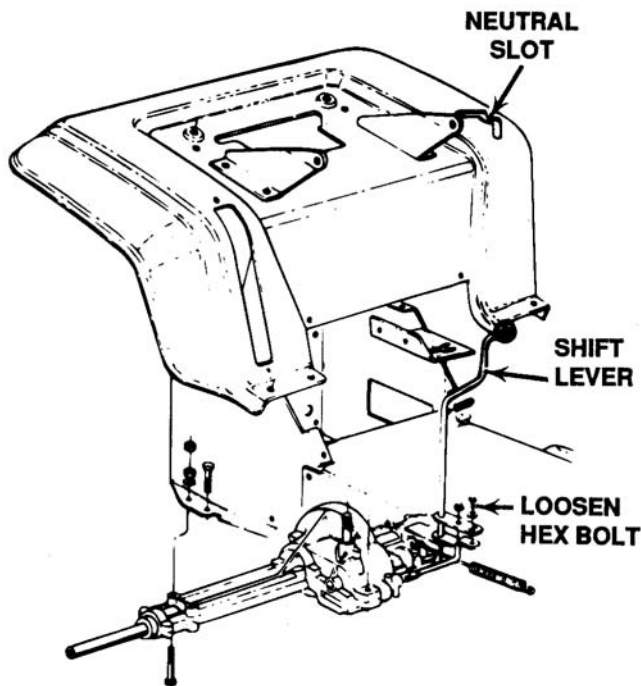
10. Place the speed control lever in parking brake position.
11. Thread the ferrule on the rod until the ferrule slips into the bottom end of the slot in the speed control lever, then thread the ferrule down on the rod one full turn (to shorten). If the speed control lever is not slotted, thread the ferrule on the rod until the stop on the brake rod is between 1/8 inch and 1/4 inch away from the bracket.
12. Position speed control lever as follows:
  - a. 7 + 8-speed units: Place speed control lever in second position.
  - b. 5-speed units: Place speed control lever in first position.
13. Place ferrule into speed control lever slot, and secure with flat washer and hair pin clip. Release the clutch-brake pedal.

See Figure 7-2 and adjust the speed control link as follows to obtain the correct neutral adjustment:

1. Push the clutch-brake pedal backward by hand as far as it will go using light pressure. Hold it in this position as you make the following adjustment.
2. Thread the speed control link into or out of the ferrule until it aligns for proper mounting to the variable speed bracket.
3. Secure the speed control link to the variable speed bracket with flat washer and cotter pin.

Adjust shift lever to neutral (wheel drive) as follows:

1. Place the transmission in neutral. (The unit will move freely when pushed forward and backward with the parking brake released.)
2. Loosen the bolt which secures the shift lever assembly to the shift lever adjusting link. See Figure 7-3.



**Figure 7-3. Adjusting Shift Lever to Neutral**

3. Place the shift lever in the neutral slot.
4. Tighten the bolt to 13 ft-lbs.

**➔ NOTE**

If a customer's unit will not release out of forward or reverse gear, first check the drive belts. The transmission pulley must come to a complete stop while clutching. If it doesn't, a speed control adjustment may help. Also check the belt guards. They must be set at 1/8 inch while the belts are engaged.

**➔ NOTE**

Occasionally in 1987 3000 Series units, the speed control lever will not stay in the selected gear. If this unit jumps out of gear or cannot be fully engaged into gear, install a shift lever modification kit (part number 753-0466).

If unit stalls with speed control in high speed, or if unit will not operate with speed control lever in a low speed position, proceed as follows:

1. Place shift lever in NEUTRAL.
2. Restart engine.
3. Place speed control lever in high speed position.
4. Release clutch/brake pedal fully.
5. Depress clutch/brake pedal.
6. Place speed control lever in desired position.
7. Place shift lever in either FORWARD or REVERSE, and follow normal operating procedures.

**Belt Removal and Replacement.**



Disconnect the spark plug wire and ground it against the engine. Block the wheels of the unit.

1. Remove the deck belt as follows:
  - a. Place the lift lever in the disengaged position.

- b. Remove the three hex bolts (belt keepers) from the engine pulley belt guard. See Figure 7-4.

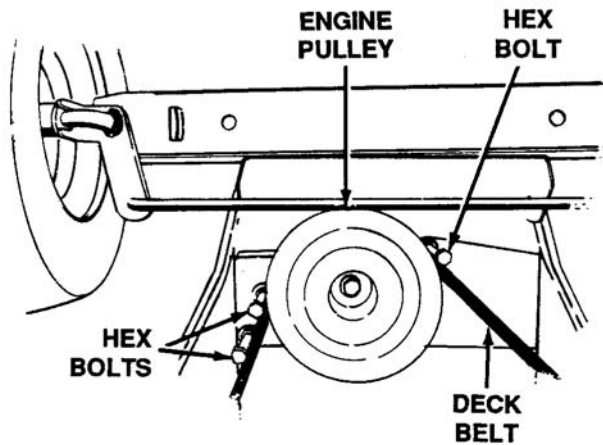


Figure 7-4. Location of Hex Bolts



Make certain hex bolts are reassembled as shown.

- c. Unhook the deck belt from the engine pulley.
- d. Place the lift lever in the engaged (all the way forward) position.
- e. Disconnect the spring from the left rear deck bracket. See Figure 7-5.
- f. Disconnect the top of the four deck links by removing the hairpin clips and flat washers.
- g. Slide the threaded rod out of the tubing. Slide the deck from beneath the lawn tractor.
- h. Remove the belt guards at each deck pulley by removing the hex bolts, lock washers and hex nuts. Remove belt. See Figure 7-6.

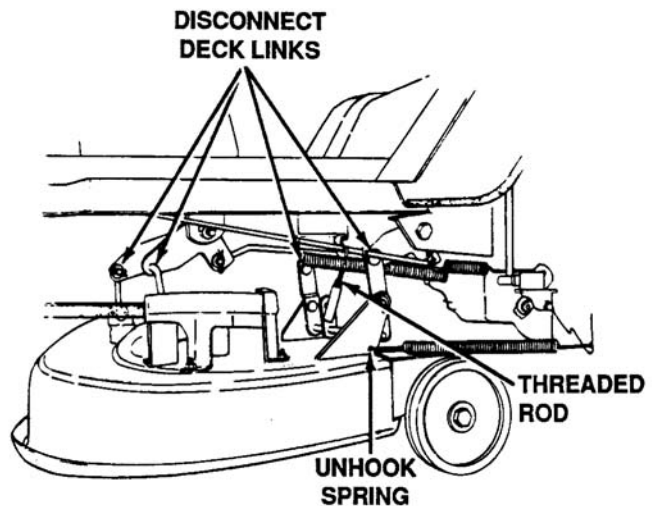


Figure 7-5. Location of Deck Links

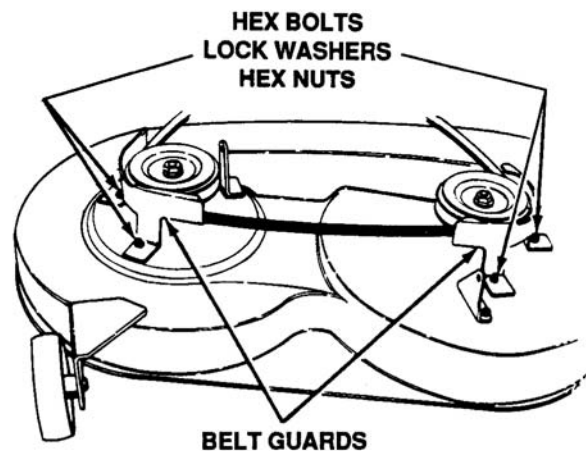


Figure 7-6. Location of Belt Guards

- i. Replace the belt following the above instructions in reverse order.
2. Remove the rear drive belt as follows:



When changing the rear drive belt, a spring puller or other suitable tool is required to remove an extension spring. A spring puller (part number 732-0571) is available to assist in removal of this spring.

- a. Remove the cutting deck by following steps a. through i. of instructions for removing the deck belt.

- b. Start the engine. Place shift lever in neutral. Place cruise control lever in high speed position and turn engine off. Engage lift lever (move all the way forward). Do not set parking brake.
- c. Disconnect the large spring from the transmission support bracket using a spring puller or other suitable tool. An access hole is provided in the rear of the frame for this purpose. See Figure 7-7.

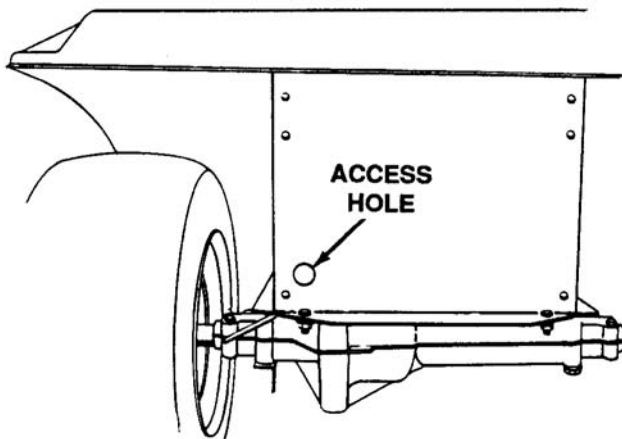


Figure 7-7. Location of Access Hole

**NOTE**

A spring puller (part number 732-0571) is available to assist in removal of this spring.

- d. Disconnect the small spring from the bolt on the right side of the frame and transmission support bracket.
- e. Remove the brake rod out of the variable speed pulley bracket.
- f. Loosen (do not remove) the bolts (or hex nut) which secure the variable speed pulley bracket to allow clearance in order to remove the belts. A 7/16 inch (or 9/16 inch) socket wrench with extension is required.

- g. Reassemble new belt, following the above instructions in reverse order.
- h. Remove the rear drive belt from around the top of the variable speed pulley. Remove belt from transmission pulley and idler pulley. See Figure 7-8.

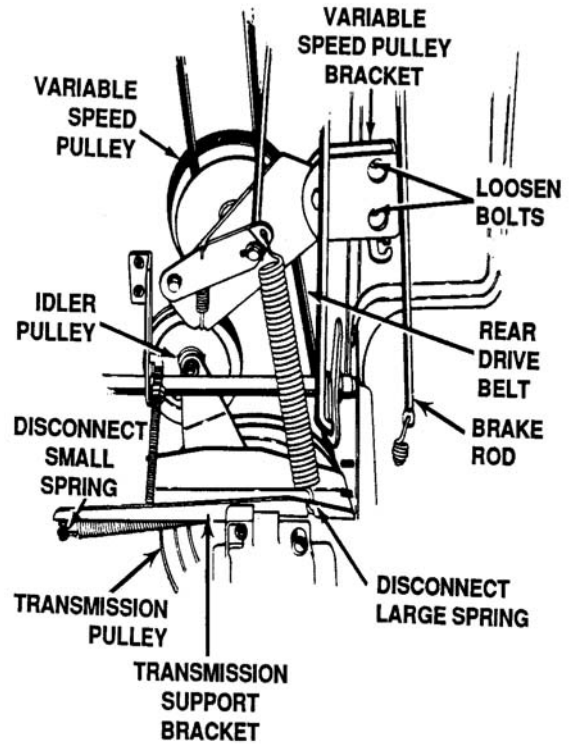
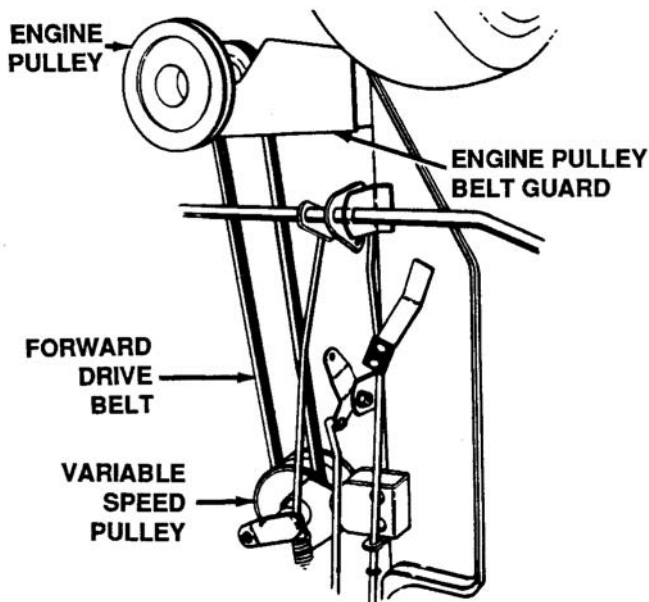


Figure 7-8. Location of Pulleys

- 3. Remove the forward drive belt as follows:
  - a. Follow steps a. through g. of instructions for removing the rear drive belt. Follow steps a. through h. of instructions for removing the deck belt.
  - b. Remove the engine pulley belt guard by removing two self-tapping screws from each side of the unit. Remove the engine pulley belt guard by moving it back and to the left. See Figure 7-9.



**Figure 7-9. Location of Forward Drive Belt**

- c. Remove the forward drive belt from the engine pulley and from the variable speed pulley.
- d. Reassemble new belt, following the above instructions in reverse order.

### REAR ENGINE RIDING MOWERS 500 SERIES.

In contrast to the earlier model variable speed drive systems the 500 Series drive system (Figure 7-12) consists of a stationary variable speed pulley with two movable idlers. These idlers pivot to change the position of the V-belt in the variable speed pulley. This pivoting action compared to the older style sliding variable speed bracket provides smoother operation and easier shifting.

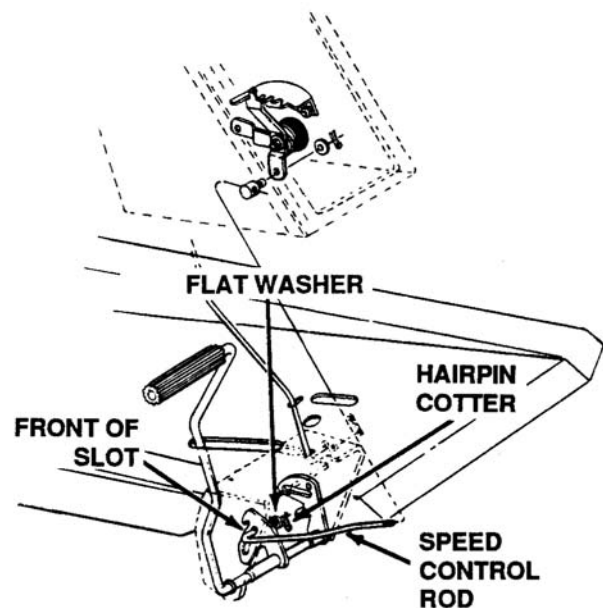
When the clutch/brake pedal is depressed, the upper idler pivots and the V-belt from the engine pulley to the V/S pulley goes slack to disengage the drive. As the clutch/brake pedal is released, the upper idler spring pulls the V-belt from the engine pulley deeper into the upper groove of the V/S pulley. This forces the transmission V-belt to the outside of the lower groove in the V/S pulley which increases the ground speed.

Adjust speed control lever as follows:

### NOTE

When operating the unit initially, or after replacing the belts, there will be little difference between the highest two speeds until after the belts have gone through a break-in period and have seated themselves into the pulleys.

1. Start the engine.
2. Place the shift lever in neutral position.
3. Place the speed control lever in high speed position.
4. Release the clutch/brake pedal completely, then slowly depress the pedal all the way (to park position). Hold the pedal in this position.
5. Turn the engine off.
6. After engine stops completely, release the clutch/brake pedal.
7. Disconnect the speed control rod by removing the hairpin cotter and flat washer. See Figure 7-10.



**Figure 7-10. Adjusting Speed Control Lever**

8. Place the speed control lever in 2nd speed position.

9. Adjust the rod by threading it in or out of the ferrule unit. It is all the way to the front of the slot as shown.
10. Secure the speed control rod using the flat washer and hairpin cotter.

Adjust shift lever to neutral as follows:

1. Place the transmission in neutral. (The unit will move freely when pushed forward and backward with the parking brake released.)
2. Loosen the bolt which secures the shift lever assembly to the shift lever adjusting link. See Figure 7-11.

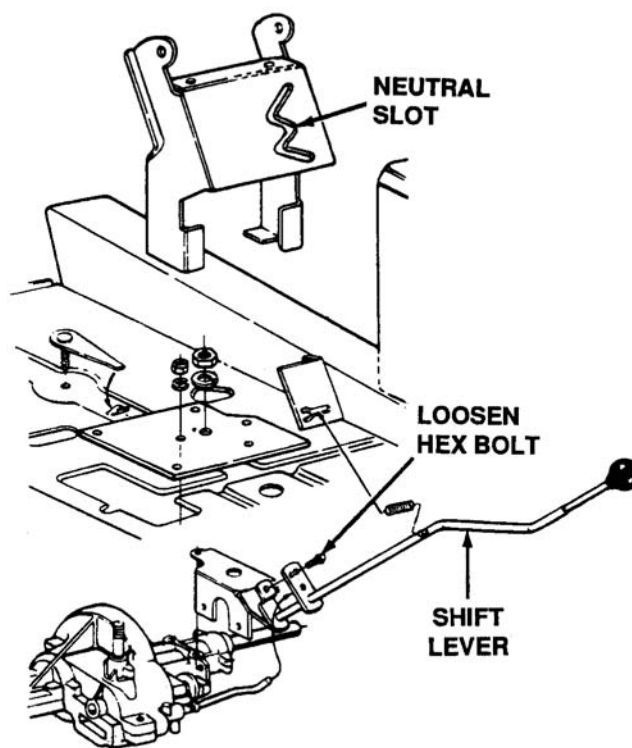


Figure 7-11. Shift Lever Assembly

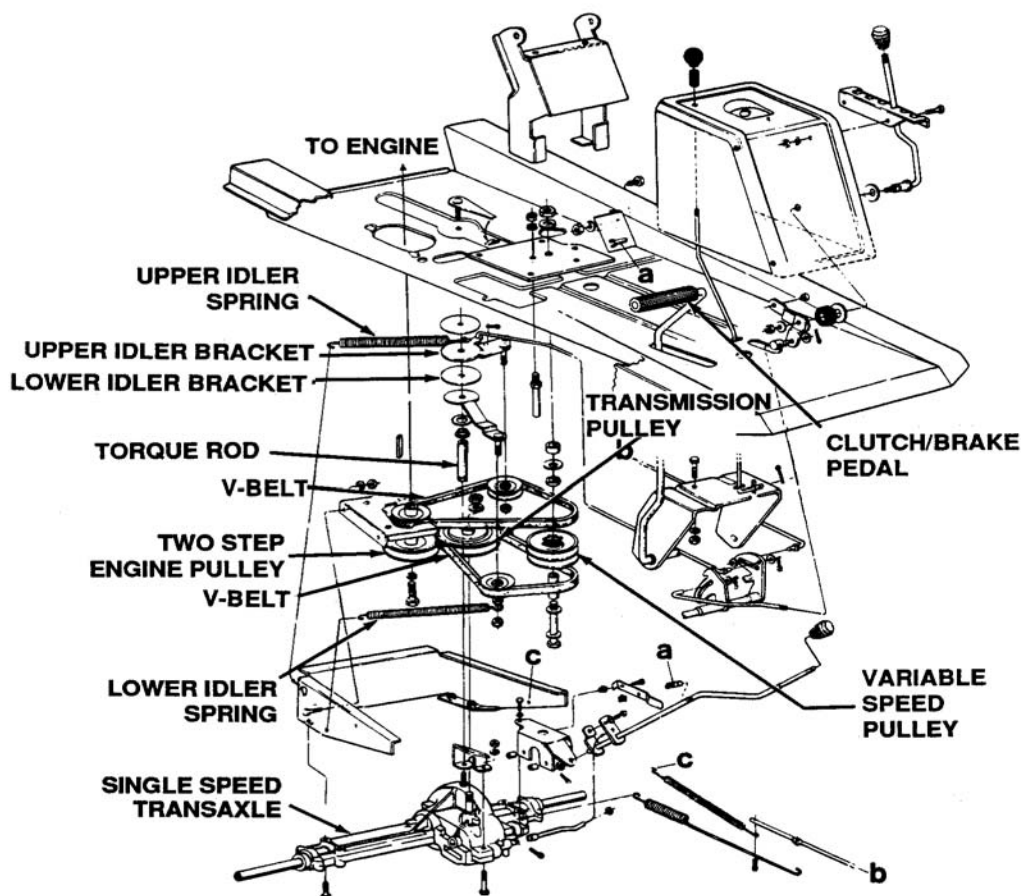


Figure 7-12. Drive System for 500 Series Mowers



- Place the shift lever in the neutral slot.
- Tighten the hex bolt to 13 ft-lbs.

Remove drive belt as follows:

**NOTE**

It is recommended that the entire instructions on belt removal and replacement be read before changing the belts.

- Remove the battery from the unit.
- To prevent gasoline from leaking from the engine, remove the fuel tank cap, place a piece of thin plastic over the neck of the fuel tank and screw on the cap.



**WARNING**

Disconnect the spark plug wire and ground it against the engine.

- Remove the deck as described in the separate deck manual.
- Unhook the idler spring from the rider frame. See Figure 7-13.

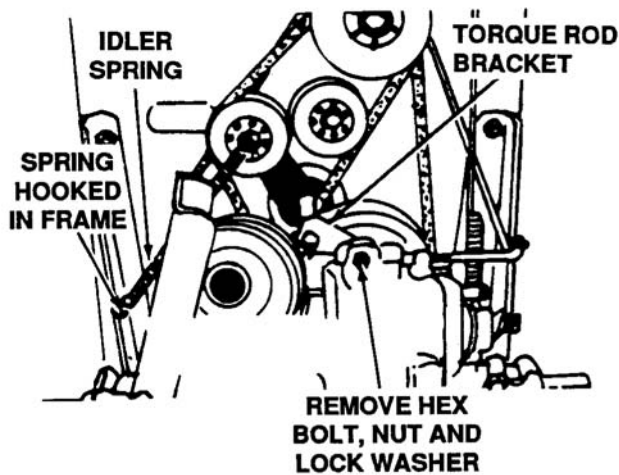


Figure 7-13. Torque Rod Bracket and Transaxle

- Remove the hex bolt, nut and lock washer at the torque rod bracket and transaxle.
- Remove the hex bolt which holds the torque rod bracket to the torque rod and remove bracket. See Figure 7-14.

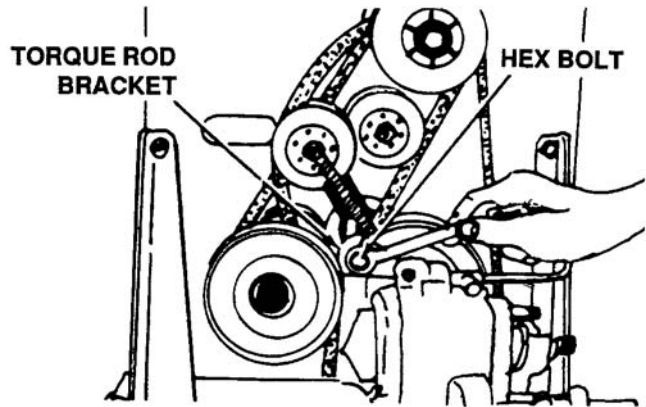


Figure 7-14. Location of Hex Bolt

- Slip the V-belt off the variable speed pulley and transaxle pulley. See Figure 7-15.

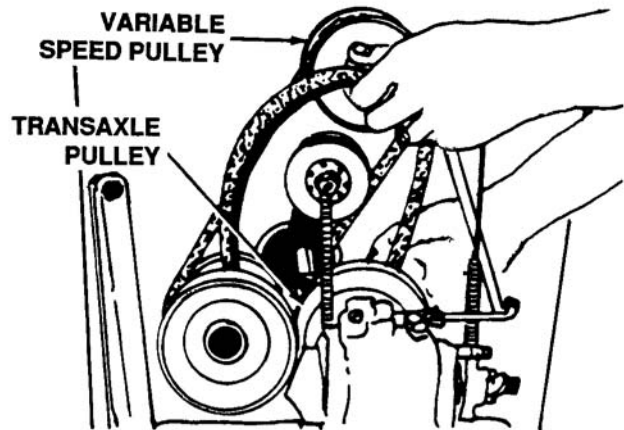


Figure 7-15. Location of V-Belt Pulleys

- Remove two hex bolts, nuts and lock washers from the engine pulley belt guard at rider frame to allow the engine pulley belt guard to drop down out of the way. See Figure 7-16.

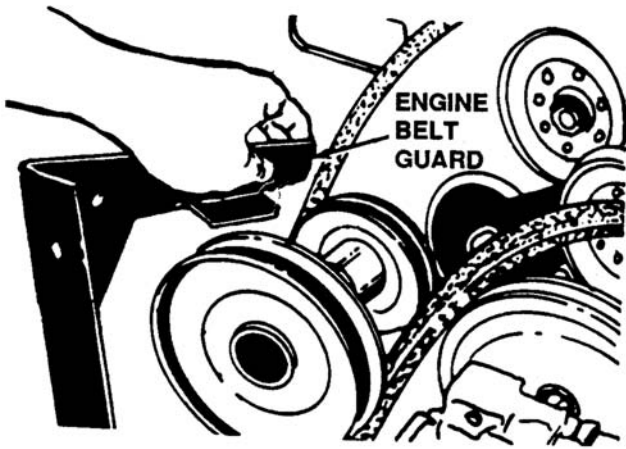


Figure 7-16. Location of Engine Belt Guard

9. Remove the idler pulley by removing the hex lock nut. See Figure 7-17.

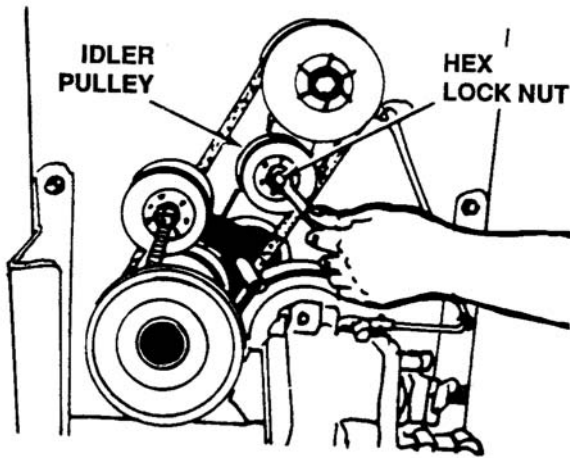


Figure 7-17. Idler Pulley Hex Lock Nut

10. Remove and replace the V-belt. See Figure 7-18.

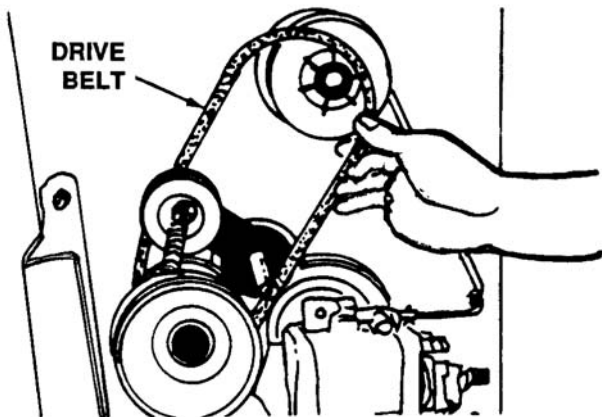


Figure 7-18. Removing Drive V-Belt

11. Upon reassembly of idler pulley, be certain the hub side of idler goes against the idler bracket. See Figure 7-19.

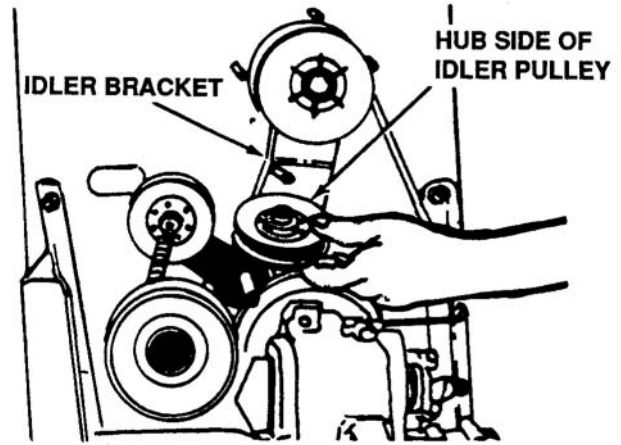


Figure 7-19. Reassembly of Idler Pulley

12. When sliding the idler pulley on the idler bracket, be certain the belt is between the pulley and guide pin. See Figure 7-20.

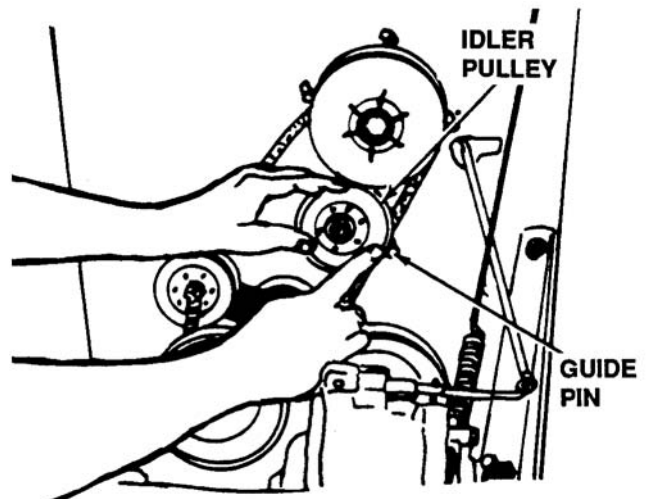


Figure 7-20. Location of Guide Pin

13. Reverse the above steps (paying close attention to steps 12 and 13) when reassembling the new belts.

**➡ NOTE**

Be certain all belts are inside belt guards and keepers. Also, be sure to reassemble the safety wire (yellow) at the deck chute.

**TRANSMATIC LAWN TRACTORS 600 A.**

The principle of this drive system is basically the same as discussed earlier in the operation

of the variable speed pulley. Refer to paragraph 7-1. This paragraph contains specific information applicable to the 600 and 700 transmatic lawn tractors only. The layout of the drive system is somewhat different. On the previously used system, constant tension was maintained on the V-belt from the variable speed pulley to the transaxle pulley through the movement of the variable speed pulley in an arc like fashion. In the new system the variable speed pulley pivots back and forth. A spring loaded idler pulley is positioned between the variable speed pulley and transaxle pulley to maintain this tension. See Figure 7-23. See Page 7-12.

1. There may be times when the customer will not be able to obtain a full speed range. This may be caused by the brackets occasionally hanging up after substantial use. You will need to disassemble the variable speed bracket assembly and the variable speed torque bracket assembly, take out the nyliner bushings, clean shafts, grease and reinstall. Perform a variable speed control adjustment.
2. If a unit in the 600 Series sits crooked, raise the right front tire approximately 6 inches and block. Loosen the 4 transaxle bolts which secure the axles to the side frames. The holes in the side frames are slotted. After loosening the bolts the transaxle will shift into position. Tighten the bolts and remove the block from under right front tire. This procedure will reposition the transaxle and level the unit.
3. You may see some problems with the steering arm front axles bending on units with rear bagger and wheel weights. A new steering arm (part number 16481A) is available. It has also been determined that wheel weights are not needed on 600 Series riders with the 063 or 064 rear baggers.

### Speed Control Adjustment.



When operating the unit initially or after replacing the belts, there will be little difference between the highest two speeds until after the belts have gone through a break-in period and have seated themselves into the pulleys.

1. First, adjust the speed control lever by pushing the clutch/brake pedal forward until the stop on

the speed control rod is against the running board rod (or until the stop on the brake rod is against the frame, if so equipped). Have another person hold the pedal in this position as you make the following adjustment. Place the speed control lever in parking brake position. Remove the hair-pin cotter and flat washer, and adjust the ferrule on the rod so it is against the back end of the slot. Then lengthen the rod one more turn. Replace the flat washer and hairpin cotter. See Figure 7-25.

2. Adjust speed control link as follows:
  - a. Start the engine.
  - b. Place the shift lever in neutral position.
  - c. Place the speed control lever in high speed position.
  - d. Release the clutch/brake pedal completely, then slowly depress the pedal all the way (to park position). Hold the pedal in this position.
  - e. Turn the engine off.
  - f. After engine stops completely, release the clutch/brake pedal.
  - g. Position speed control lever as follows:
    - (1) 7-speed units—Place speed control lever in second position.
    - (2) 6-speed units—Place speed control lever between first and second position (hold in this position).
    - (3) 5-speed units—Place speed control lever in first position.
  - h. Remove the cotter pin and flat washer which secures the speed control link to the variable speed torque bracket assembly.
  - i. Push the clutch/brake pedal backward by hand as far as it will go using light pressure. Hold it in this position as you thread the speed control link in or out of the ferrule until it lines up with the pin on the variable speed torque bracket assembly.

- j. Secure speed control link to variable speed torque bracket assembly with flat washer and pin cotter.

**Belt removal and replacement.** It is not necessary to tip the unit to remove the belts. However, if tipping the unit is desired, remove the battery from the unit. To prevent gasoline leakage, drain the gasoline, or remove the fuel tank cap, place a thin piece of plastic over the neck of the fuel tank and screw on the cap. Be certain to remove the plastic when finished changing the belts. Block unit securely. Replace belts as follows:



**WARNING**

Disconnect the spark plug wire and ground it against the engine. Block the wheels of the unit.

1. Rear drive belt. Remove and replace rear belt as follows:
  - a. Place shift lever in neutral position. Unscrew the shift knob and the speed control knob (if located on the console). Remove the two truss head screws which secure the transmission cover. See Figure 7-21.
  - b. Lift the transmission cover. Unplug the safety wire from beneath the transmission cover. See Figure 7-22. Remove transmission cover.

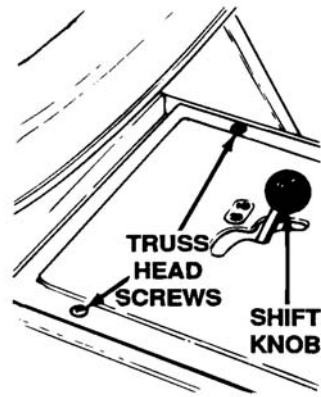


Figure 7-21. Transmission Cover



Figure 7-22. Safety Wire

- c. Push the idler pulley toward the right side of the unit. Lift the belt over the idler pulley. See Figure 7-26. See Page 7-16.
- d. Remove the belt from the variable speed pulley.
- e. Remove the two bolts which hold the shift lever bracket to the frame on the left side of the unit. Swing the bracket toward the right so the belt can be removed from the transmission pulley. See Figure 7-26. See Page 7-16.

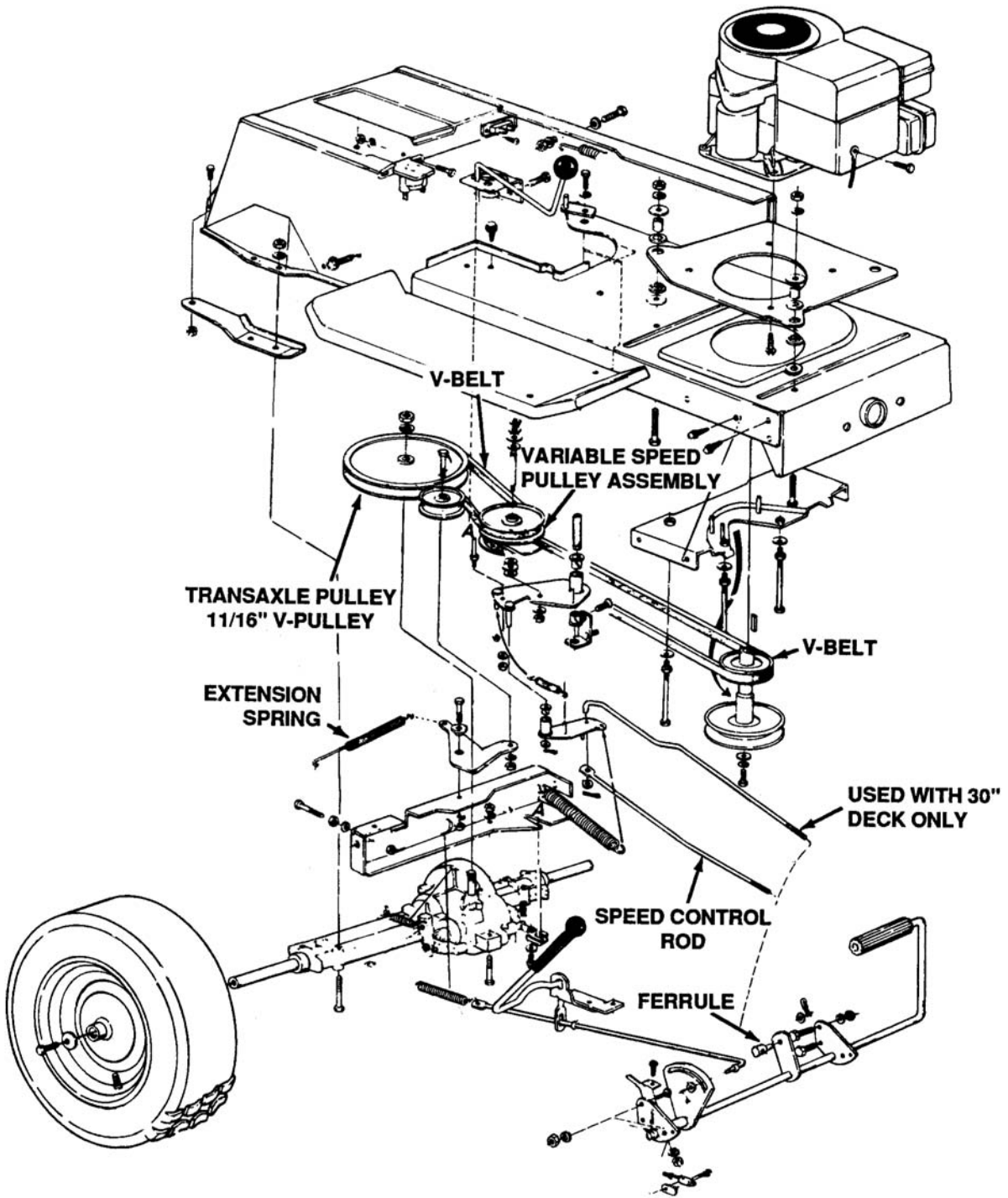


Figure 7-23. Variable Speed Drive System for 600 and 700 Series

## Model 600 Series

In many cases, we have found if speeds cannot be obtained after checking major components and performing a variable speed adjustment, the problem usually is between the variable speed bracket assembly and torque bracket assembly not fully pivoting.

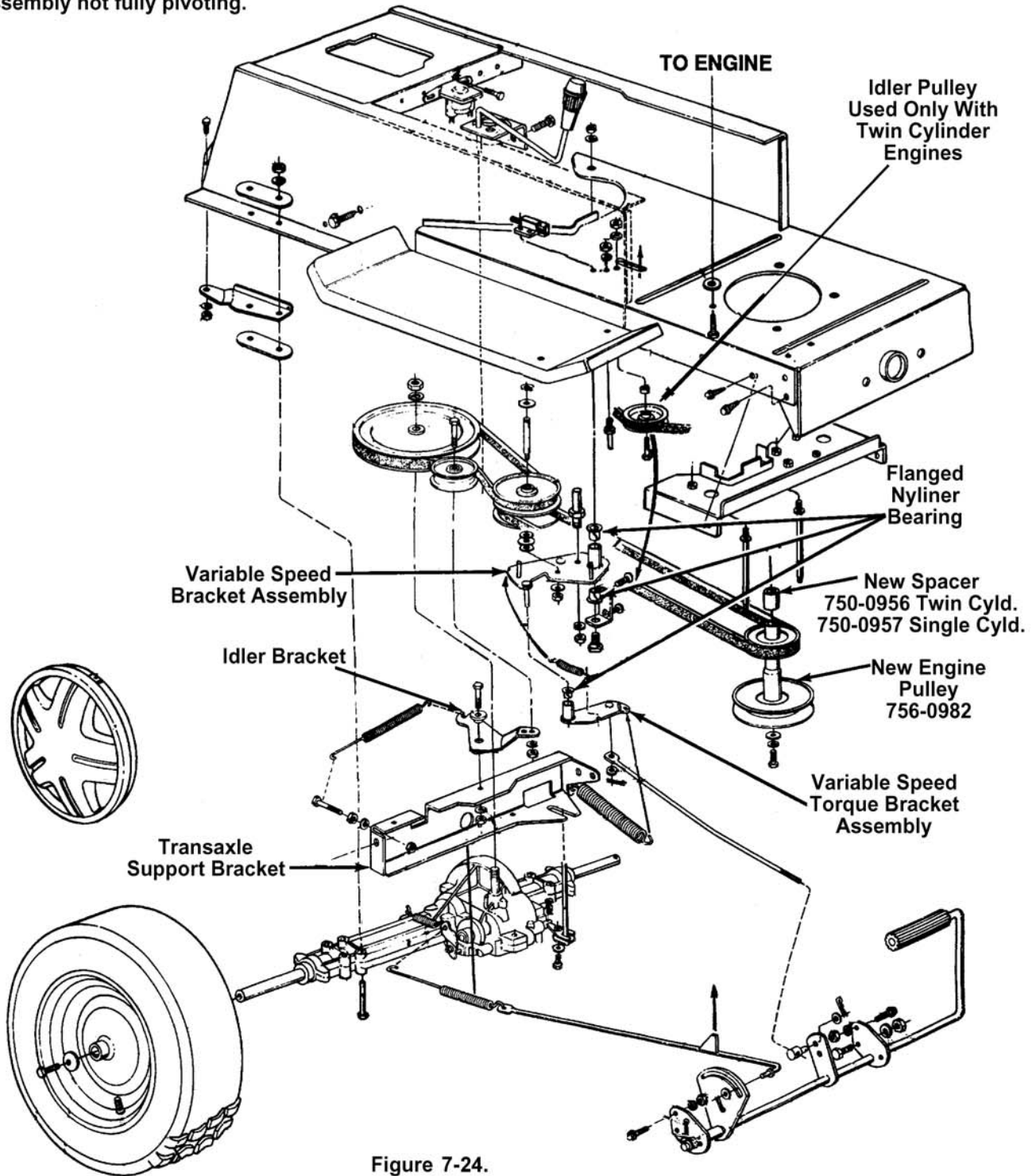


Figure 7-24.

### \*\*REAR WHEEL CHART

Description	18" x 9.50"	18" x 6.50"	20" x 8.0"	20" x 8.0"
Wheel Ass'y. Comp.	734-0817	734-0592	734-1675	634-0104
Tire Only	734-0448	734-0294	734-1596	734-1730
Rim Only	634-0070	634-0069	634-0070	634-0070

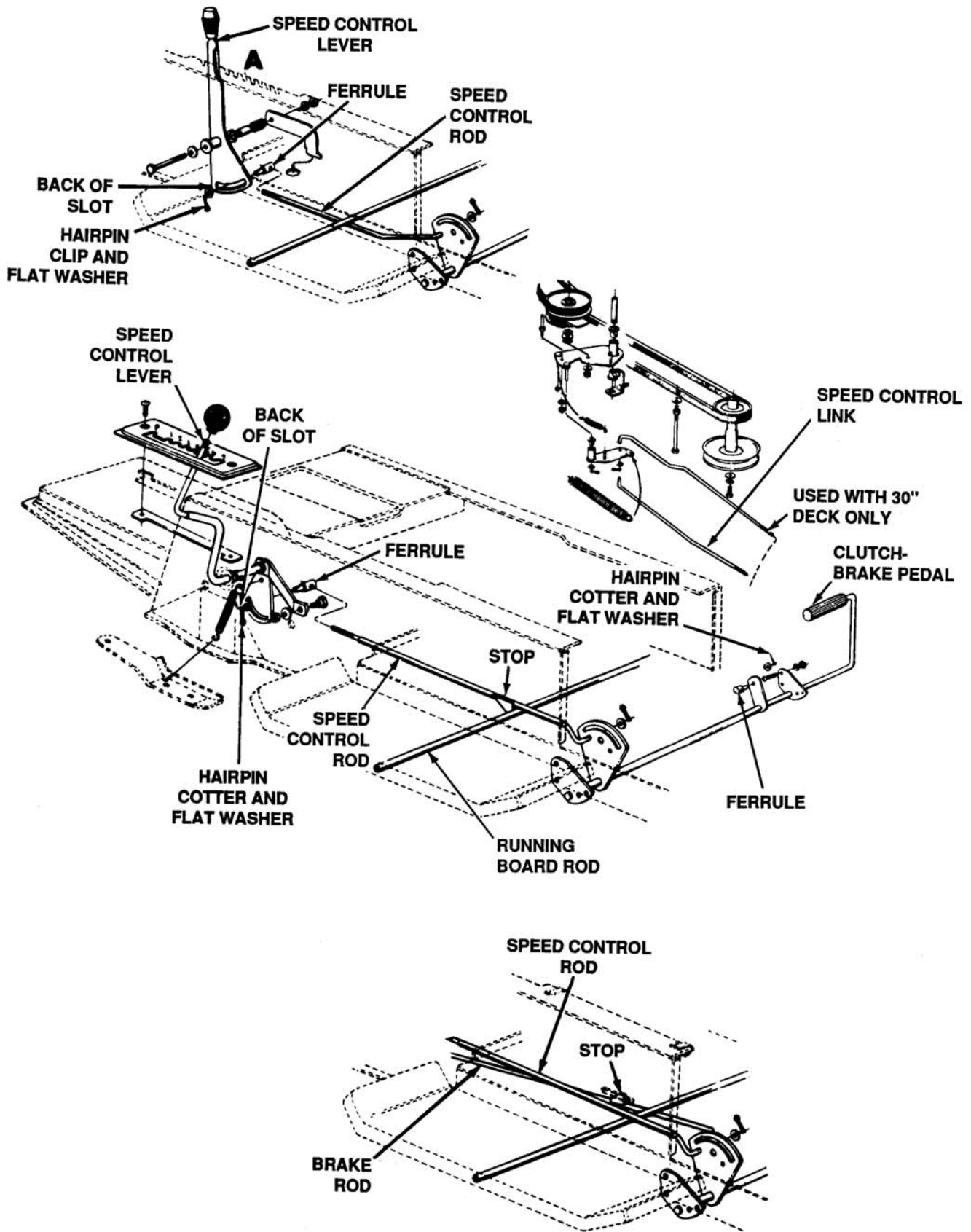


Figure 7-25. Speed Control

# SERVICE KIT

## 753-0635

**CODE:** R-365  
**DATE:** April 25, 1995  
**SUBJECT:** Replacement Engine Pulley—  
 Transmatic Lawn Tractors

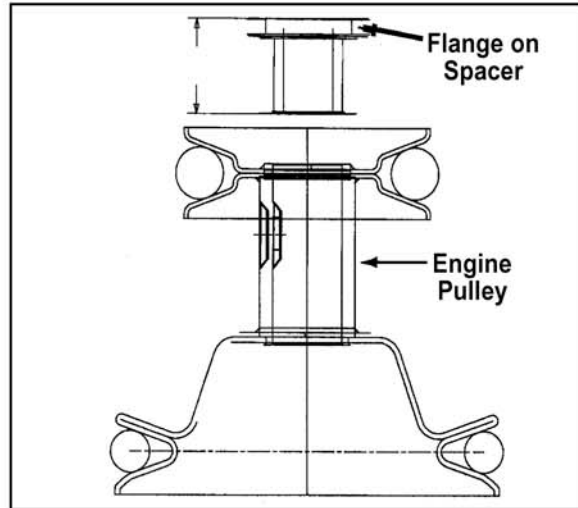
**Service Kit 753-0635 replaces engine pulley part number 756-0488.**

Install the new pulley and spacer. The flange on the spacer **must** be toward the **top** as shown. Tighten the pulley mounting screw to 600-720 in. lbs.

**Kit 753-0635 Consists of:**

Part No.	Description	Qty.
756-0982	Engine Pulley	1
750-0957	Spacer 1-1/4" Lg.	1

Used on Single Cyld. Engines



FORM NO. 770-8983K

# SERVICE KIT

## 753-0631

**CODE:** R-363  
**DATE:** March 1, 1995  
**SUBJECT:** Replacement Engine Pulley—  
 Transmatic Lawn Tractors

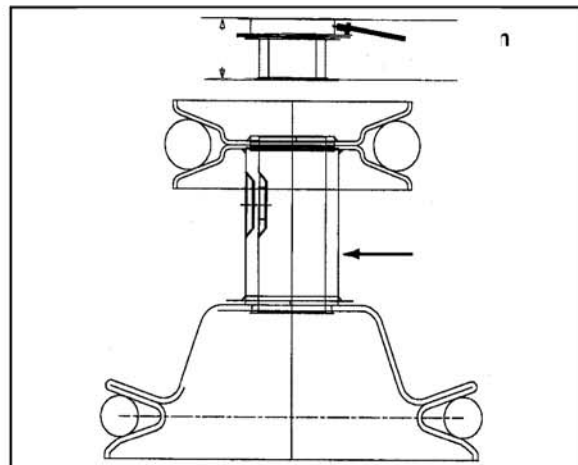
**Service Kit 753-0631 replaces engine pulley part number 756-0424.**

Install the new pulley and spacer. The flange on the spacer **must** be toward the **top** as shown. Tighten the pulley mounting screw to 600-720 in. lbs.

**Kit 753-0631 Consists of:**

Part No.	Description	Qty.
756-0982	Engine Pulley	1
750-0956	Spacer 13/16" Lg.	1

Used on Twin Cyld. Engines



FORM NO. 770-8979K  
 (R950425)



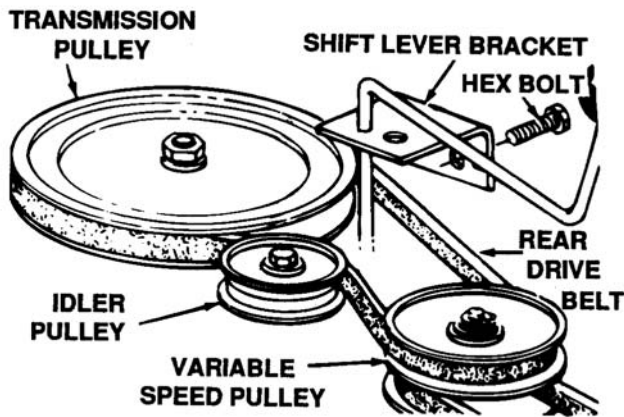


Figure 7-26. Location of Shift Lever

- f. Replace belt, and reassemble in reverse order.
  - g. Adjust the speed control as instructed in adjustment section.
2. Front belt drive. Remove and replace front belt as follows:
    - a. To remove the front drive belt, first remove the rear drive belt from the idler pulley and variable speed pulley.
    - b. Place the lift lever in the disengaged position.
    - c. Remove the belt keeper pins from the engine pulley belt guard. Refer to Figure 7-27.
    - d. Unhook the deck belt from the engine pulley.
    - e. Remove the two self-tapping screws on each side of the frame which hold the engine pulley belt guard to the frame. See Figure 7-27. Remove the engine pulley belt guard by slipping it forward and down.

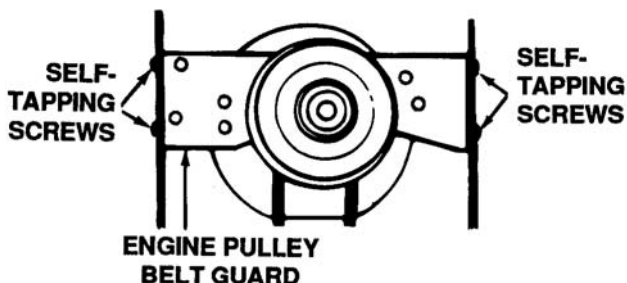


Figure 7-27. Location of Belt Guard

- f. Place the clutch-brake pedal in park position.
- g. Push forward on the variable speed pulley, and lift the belt off the engine and remove the belt from the engine pulley.
- h. Release the clutch-brake pedal. Using the pedal to move the variable speed pulley as necessary, lift the belt up and off the variable speed pulley.

**NOTE**

When reassembling, make certain belt is inside the pins. See Figure 7-28.

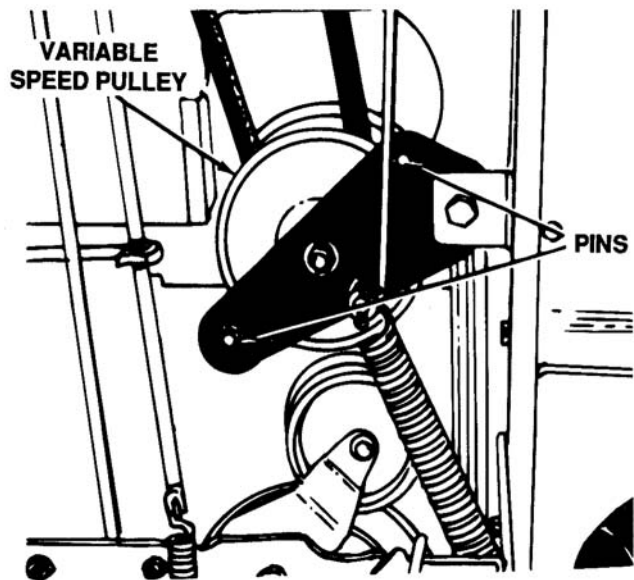


Figure 7-28. Location of Variable Speed Pulley and Pins

- i. Reassemble with a new belt, following instructions in reverse order.
- j. Adjust the speed control as instructed in adjustment section.

## Model 600 Series

## Variable Speed

**Problem:** Why does my 600 series rider with transmatic drive slow down excessively on moderate grades?

**Note:** It is entirely natural for our transmatic drive lawn and garden tractors to slow down while climbing a grade. This is a unique and safe feature of our MTD riding equipment. Once the unit has reached the top of the grade it will immediately resume its pre-set speed. If slow down is excessive you can change the variable speed spring.

**Solution:** Change variable speed spring 732-0556 7.57" to new spring 732-0459 6.74" lg. approximately 3/4" differential.

**Note:** Before attempting the above part change, make absolutely sure that both the front and rear drive belts are in good condition and that the variable speed drive components are operating freely and are adjusted properly.

**Problem:** My 1996 600 series rider has premature battery failure.

**Solution:** Check for proper ground.

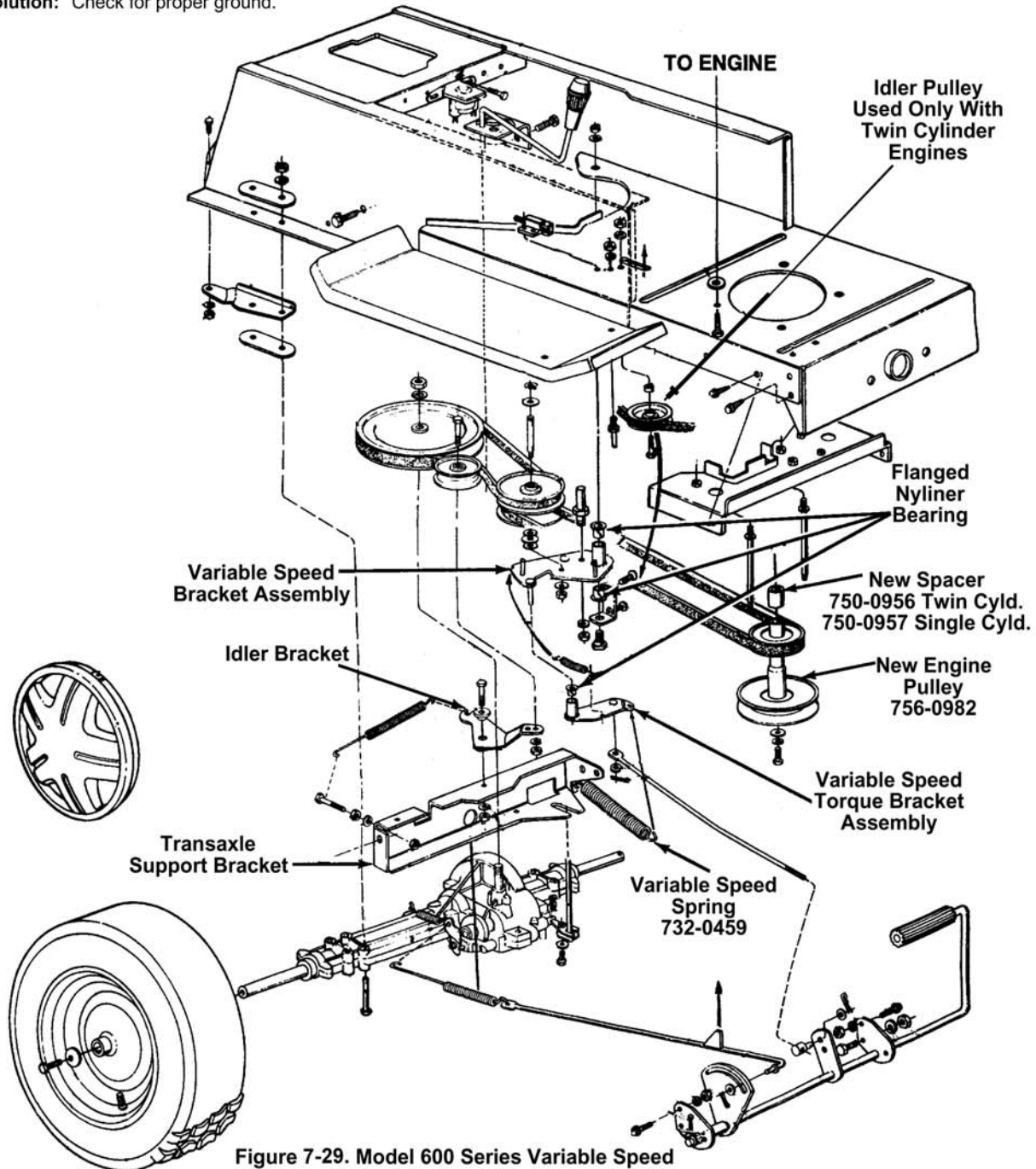


Figure 7-29. Model 600 Series Variable Speed

In many cases, we have found if speeds cannot be obtained after checking major components and performing a variable speed adjustment, the problem usually is between the variable speed bracket assembly and torque bracket assembly not fully pivoting.

Subject: Service Kit drag link installation for model 600 & 800 series tractors 1996 production

Problem: The drag link (the rod between the steering segment and the steering arm on the right front wheel) could be installed incorrectly. **Note:** The end of the drag link with the letter "A" stamped into it must be to the rear 800 series only.

Solution: Remove and reinstall the drag link correctly. Time allowance: .5 hour Service Kit Drag Link 600 Series Rider 753-0654 Service Kit Drag Link 800 Series Tractor 753-0674

Tools Required: 1/2" and 9/16" open end wrenches.

1. Turn the steering wheel completely to the right until it bottoms out.
2. Loosen the jam nuts on both the front and rear ball joint.
3. Remove the front ball joint by removing the hex nut on the front ball joint.
4. Unscrew the drag link from the rear of the ball joint.

5. Unscrew the drag link from the front ball joint.
6. Verify the letter "A" is towards the rear of the tractor and thread into the rear ball joint approximately 1".
7. Screw in the front ball joint approximately 1/2".
8. With the steering wheel turned as far as it can turn to the right and with the front tractor wheels turned to the right so they bottom out, adjust the front ball joint until it fits into the hole in the steering arm. **Note:** The spring lock washer must fit on the front ball joint before it is installed into the steering arm.
9. Install and tighten the hex nut on the front ball joint.
10. Using the 1/2" and 9/16" open end wrenches, tighten the jam nuts on the ball joints. **Note:** The drag link can swing in a short arc. When you tighten the jam nuts be sure that the drag link is near the center of the arc so it does not bind when you turn the steering wheel.

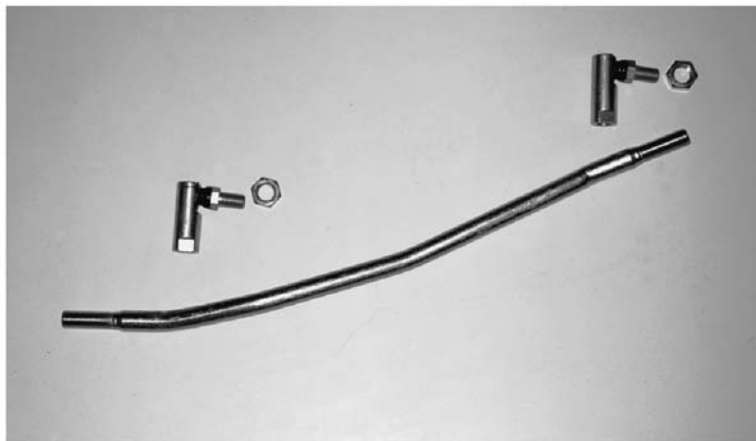


Figure 7-30. Drag Link Installation

# Service Kit 753-0668

**CODE:** R-379  
**DATE:** June 3, 1996  
**SUBJECT:** Installation of afterfire solenoid on 1996 600 series lawn tractors with 16 and 16.5 H.P. Tecumseh engines.

## INSTALLATION INSTRUCTIONS:

1. Lift open hood of tractor.
2. Disconnect the battery and spark plug.
3. Remove the left side panel. (Not required on all units.)
4. Drain gas from unit or clamp fuel line to close.
5. Remove the threaded plug from the bottom of the carburetor fuel bowl. See figure 1.
6. Remove the sealing washer from the threaded plug and place over the threaded end of the afterfire solenoid.
7. Thread afterfire solenoid into carburetor fuel bowl until snug.
8. Tighten solenoid an additional half turn with a 1/2" wrench.
9. Unplug the wire harness connector from the ignition switch in the dash. Remove the ignition switch from the dash and throw away.
10. Install new ignition switch supplied with this kit into the dash.
11. Plug the female end of the wire harness adapter supplied with this kit, onto the new ignition switch. See figure 2.
12. Push the single wire onto the open terminal of new ignition switch.
13. Connect the male end of the wire harness adapter into the wire harness on the tractor. Make sure the connectors are fully seated.
14. Route red/black wire along existing wire harness (in front of battery tray, moving towards front, left side of tractor). See figure 1.
15. Connect red/black wire to afterfire solenoid.
16. Secure red/black wire to throttle wire and wire harness with the cable ties provided.
17. Add gas to fuel tank or unclamp fuel line.
18. Reconnect battery and spark plug.
19. Start tractor and inspect carburetor fuel bowl for any leakage around afterfire solenoid. Tighten solenoid with a 1/2" wrench if necessary.
20. If removed, reattach side panel.

### Kit 753-0668 Consists of:

Part No.	Description	Qty.
725-1396	Ignition Switch	1
726-0197	Cable Tie	3
7510611204	Afterfire Solenoid	1
629-0500	Wire Harness Adapter	1

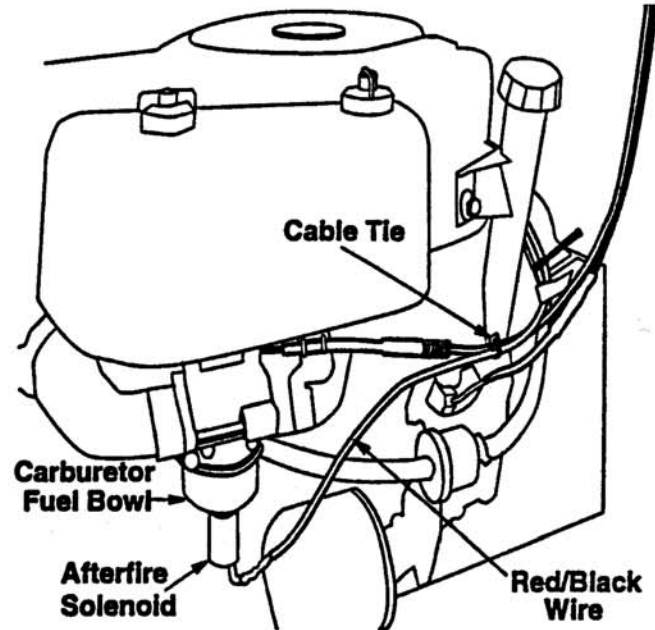


Figure 1.

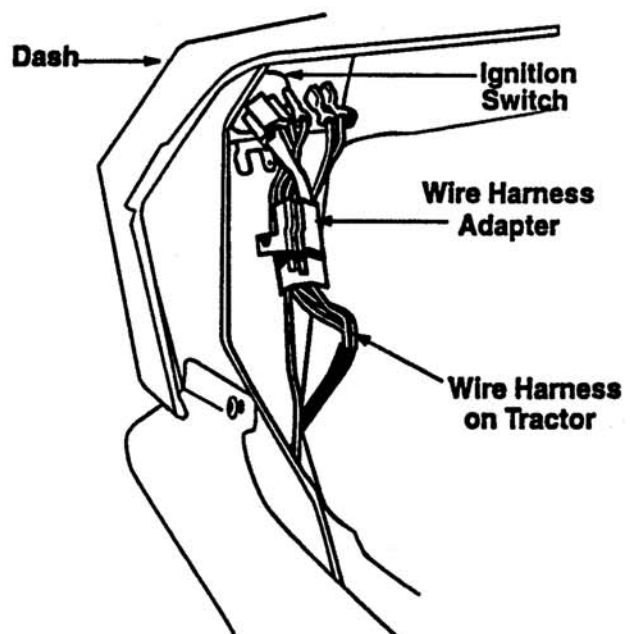


Figure 2.

**➔ NOTE**

Some of these units come equipped with an electric clutch. These units will not need a deck brake since the electric clutch performs that function.

Speed Control Adjustment. See Figure 7-31.

**➔ NOTE**

When operating the unit initially, or after replacing the belts, there will be little difference between the sixth and seventh speeds until after the belts have gone through a break-in period and have seated themselves into the pulley.



**CAUTION**

Unit **MUST NOT** be shifted into LOW, HIGH, or REVERSE GEAR while moving. Shift the speed selector **ONLY** while the unit is running or the speed control rear link could bend, affecting the speed control adjustment.

1. Proceed with adjustment as follows:

a. Start the engine.

- b. Place the shift lever in NEUTRAL position.
- c. Place the speed control lever in seventh speed position.
- d. Release the clutch/brake pedal completely and slowly depress the pedal all the way (to park position). Hold the pedal in this position.
- e. Turn the engine off.
- f. After engine stops completely, release the clutch/brake pedal.
- g. Disconnect the rear speed control link from the variable speed torque bracket by removing the cotter pin and flat washer.
- h. Place the speed control lever in the first position.
- i. Disconnect the front speed control link from the variable speed torque bracket by removing the cotter pin and flat washer.

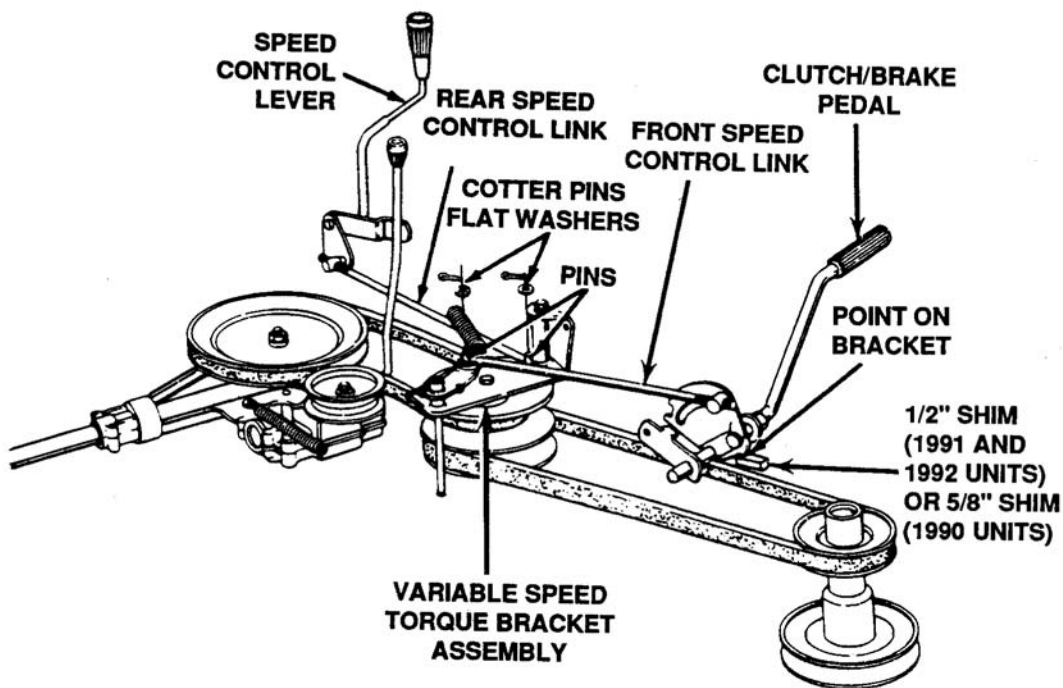


Figure 7-31. Speed Control System

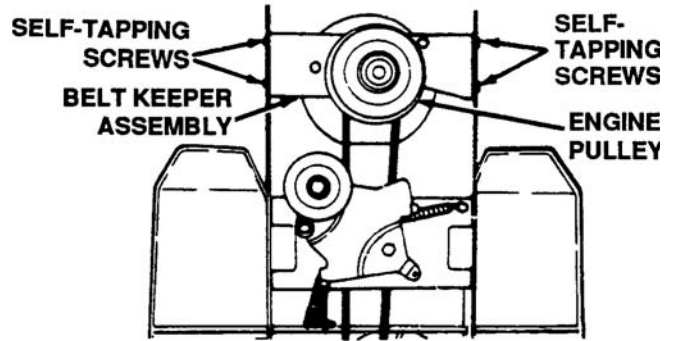
- j. Place a 1/2 inch shim (for 1991 and 1992 units) or a 5/8 inch shim (for 1990 units) under the point of the bracket on the clutch/brake pedal as shown in Figure 7-31.
- k. Thread the front speed control link in or out of the ferrule until the hole in the link lines up with the pin on the variable speed torque bracket. Secure with the flat washer and cotter pin removed in step i.
- l. Push the rear speed control link backward using light pressure, and hold it in this position as you thread it into or out of the ferrule until the hole in the link lines up with the pin on the variable speed torque bracket. Then turn the link clockwise two more times (making it longer).
- m. Move the speed selector toward the right so the hole in the rear speed control link fits over the pin on the variable speed torque bracket. Secure with the flat washer and cotter pin removed in step g.
- n. Remove the shim from beneath the bracket on the clutch/brake pedal.

**→ NOTE**

You might find that the unit jumps out of high gear. Before you get into extensive repair, check to see that the gear shift lever has not been bent. A bent lever could be rubbing against the drive belt causing it to be pushed out of gear by the belt.

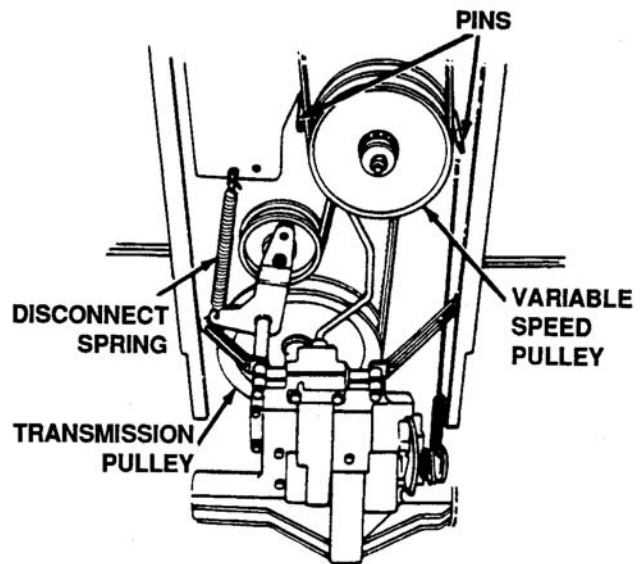
**Belt Removal and Replacement.**

1. Remove and replace front belt as follows:
  - a. Depress the clutch pedal and set parking brake.
  - b. Remove the deck from the tractor.
  - c. Raise and block the front wheels of the tractor so you can work under it.
  - d. Remove the four self-tapping screws which hold the belt keeper assembly to the frame at the engine pulley. Push the belt keeper assembly forward, out of the way. See Figure 7-32.



**Figure 7-32. Belt Keeper Assembly**

- e. Remove the two pins which act as belt keepers by the variable speed pulley. See Figure 7-33.



**Figure 7-33. Location of Pins**

- f. Roll the belt off the variable speed pulley and remove from the engine pulley.
  - g. Install the new belt following instructions in reverse order.
2. Remove and replace rear belt as follows:

**→ NOTE**

If the rear drive belt comes off, the idler pulley may need to be repositioned to the rear hole of the idler bracket assembly. Another cause for rear drive belt failure is the idler bracket not being in line with the variable speed pulley and transmission pulley. This can be corrected by

ordering a new idler bracket assembly or bending the bracket in line.

- a. First remove the front drive belt as instructed in the previous section.
  - b. Disconnect the spring which secures the idler pulley to the frame.
  - c. Remove the transmission cover by unscrewing the two knobs, and removing two truss machine screws.
  - d. Roll the belt over the top of the transmission pulley. Remove belt from the variable speed pulley.
  - e. Install the new belt, following instructions in reverse order.
3. Changes and replacements.
- a. For 1991, a bracket was added to the foot pedal assembly to accommodate the foot pedal bracket assembly and spring. This improves the speed control response time by applying backward pressure on the foot pedal assembly.
  - b. Units in which the rear cog style belts come off or continues to drive when the clutch is disengaged can be repaired by installing kit number 753-0526. This type of condition is due to a bent or distorted variable speed bracket assembly, idler bracket and/or torque bracket. Verify bent condition before installing kit. If bent condition **does not** exist install belt kit listed below.
  - c. For units produced with the cog style rear belts (part numbers 754-0360 and 754-0358, early 1991 and prior production) which require belt replacement, the belt must be replaced with a smooth style belt. If rear cog belt is ordered, both front and rear belts will be shipped and must be replaced as a set. Order kit number 753-0528. Kit consists of smooth style belts

part number 754-0432 (rear) and part number 754-0358 (front).

 **NOTE**

On some late 1989 and early 1990 800 Series tractors, under a heavy load such as pushing snow, the unit may not stop because the drive belt hangs up in the engine pulley and does not release. The front and rear drive belts have been changed from cog belts to wrap belts. The new front belt (part number 754-0358A) will retrofit with no problem. If you need to retrofit the rear belt, you must order a new variable speed pulley (part number 717-0945) with the new belt (part number 754-0362).

- d. Late production, 1991 units were manufactured with a smooth rear belt (part number 754-0362). When replacement of this belt is necessary, do not order above kit. This smooth style belt should not be confused with the 754-0432 belt. The length of these two belts are different and cannot be interchanged.

**Shift Lever.** The shift lever is located in the center of the console and has four positions, HIGH, LOW, NEUTRAL and REVERSE. See Figure 7-35. The clutch-brake pedal must be depressed and the lawn tractor must not be moving when shifting gears. Do not force the shift lever. Release the clutch-brake pedal slightly to line up the shifting collar in the transmission. Then try to shift gears.

**Speed Control Lever.** The speed control lever is located on the left fender. It allows you to regulate the ground speed of the lawn tractor. See Figure 7-36. To select the ground speed, depress clutch pedal. Push speed control lever outward and move backward to slow lawn tractor, move forward to increase speed. When desired speed has been obtained, release lever in that position. Whenever clutch is engaged, unit will automatically go to the pre-set speed.

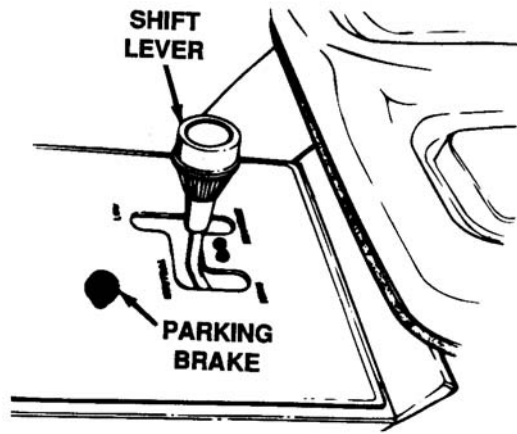


Figure 7-34. Shift Lever

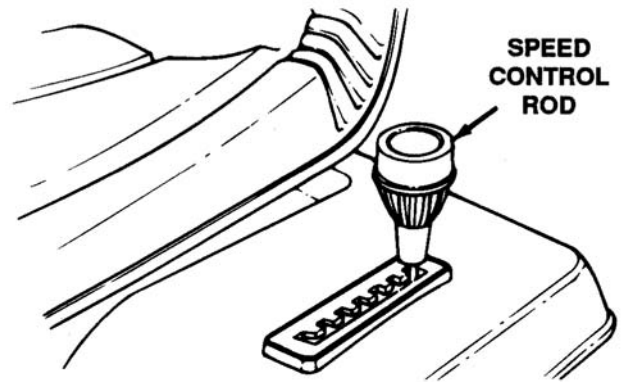


Figure 7-35. Speed Control Lever

## 400 Series

### Step-Thru Frame

Heavy-Duty Uni-Frame construction made of 12 gauge steel. Footrests are built-in as an integral part of the frame. The Uni-Frame has less bolted and welded parts to increase strength and durability.

Frame is not capable of using any front or rear mount attachments other than grass catchers (when used with front wheel weights) or hitch pin attachments. The step thru design makes it convenient. Easy on and off.

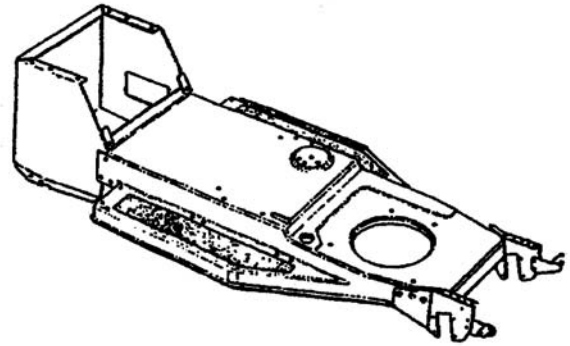


Figure 7-36. 400 Series Frame Identification

## 600 Series

### Lawn Tractor Frame

The Durable Box 600 Series Frame is also made from heavy-duty 12 gauge steel. The box design provides added strength for the use of attachments and accessories such as snow throwers and dozer blades.

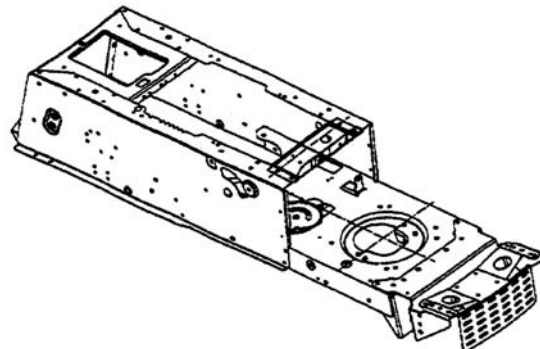


Figure 7-37. 600 Series Frame Identification



# TRACTORS

## HYDROSTATIC DRIVE 600 SERIES (See Figure 7-38).

### Hydrostatic Neutral Control Adjustment.

The hydrostatic transmission control is in correct

If you encounter loss of power, check the plastic vent plug to insure of proper ventilation. Also check hydrostatic filter, and all external linkages prior to condemning the hydrostatic unit.

adjustment when the tractor does not move with the engine running, the clutch engaged and the hydrostatic control lever in the neutral position.

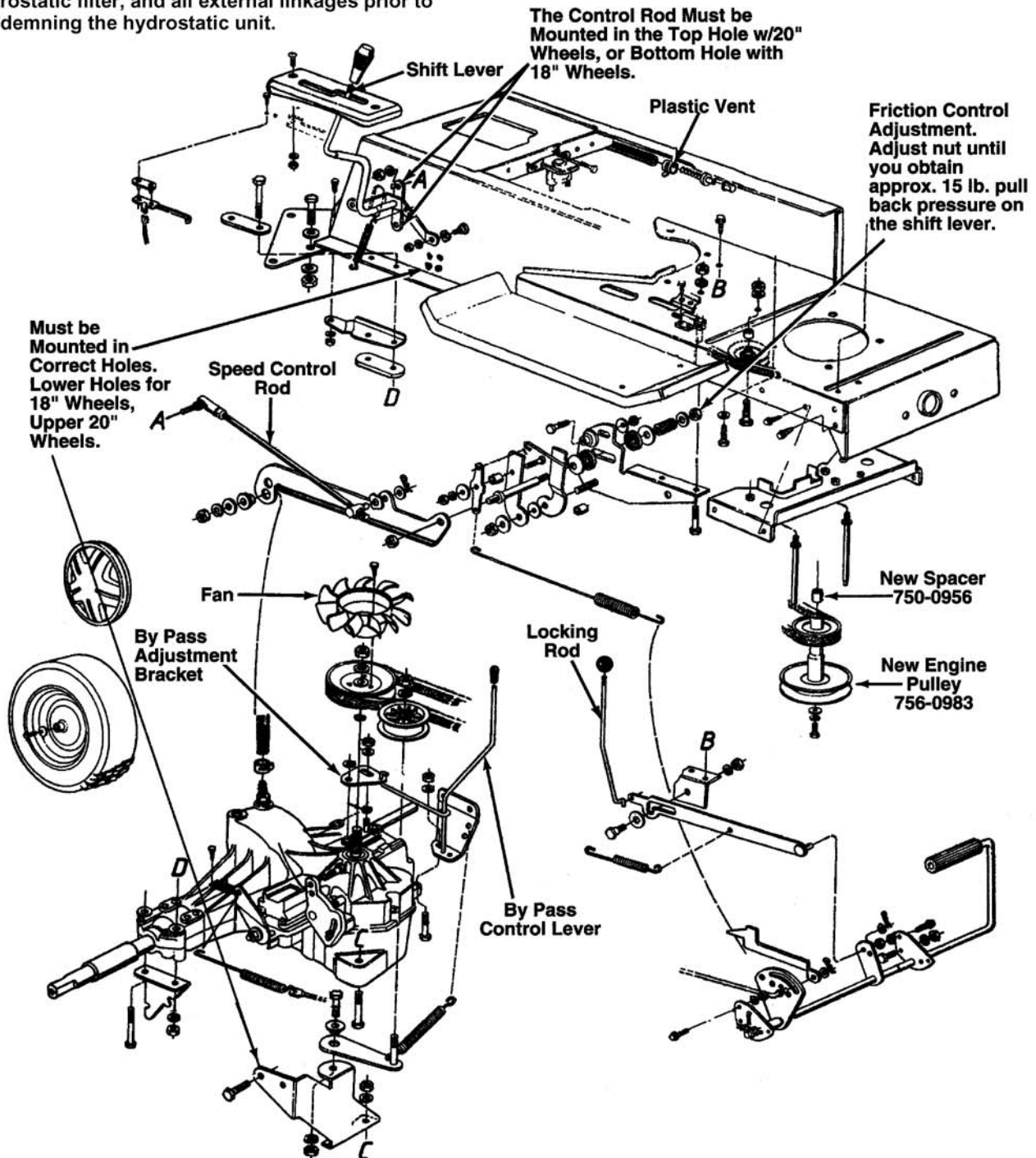


Figure 7-38. Hydrostatic Drive 690-699 Series

If adjustment is necessary, follow these steps:

1. Raise one rear wheel off the ground by placing a block under the rear frame.
2. Remove the transmission panel by removing the parking brake knob and truss machine screws.
3. Loosen the hex jam nut on the speed selector adjusting rod. See Figure 7-39.
4. Loosen the hex nut on the scissor mounting bracket. See Figure 7-39.

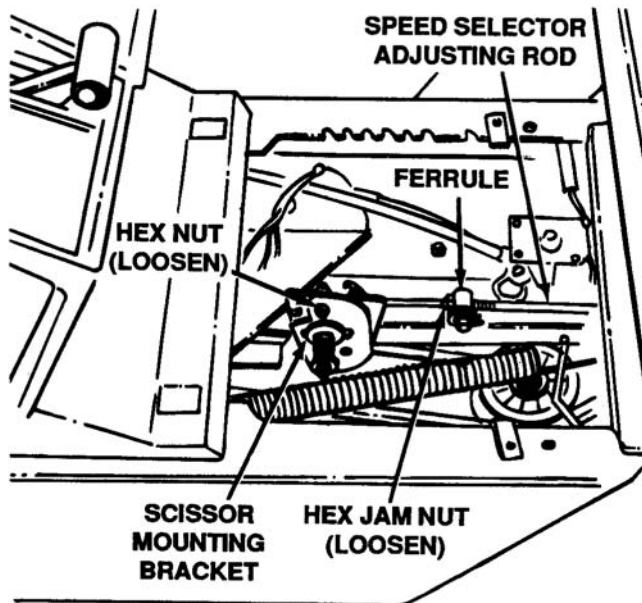


Figure 7-39. Loosening Nut on Adjusting Rod and Mounting Bracket

5. Start the engine and run at full throttle.
6. Move the hydrostatic control lever until you find neutral (rear wheels do not rotate in either direction).



**WARNING**

Be careful of the cooling fan on the hydrostatic transmission.

7. Depress the clutch-brake pedal until the wheels stop. Do not set the parking brake.
8. Shut off the engine.
9. Tighten the hex nut on the scissor mounting bracket.
10. Thread the speed selector rod in or out of the ferrule until the hydrostatic control lever lines up in the neutral position on the speed control index bracket.
11. Tighten hex jam nut against the ferrule.
12. Replace the transmission panel and parking brake knob.
13. Remove the block from under the frame and test the operation of the tractor. 12-1.2 Drive Belt (See Figure 7-40).

**Drive Belt Replacement**

1. Depress the clutch pedal and set the parking brake.
2. Remove the deck from the lawn tractor.
3. Raise and block the front wheels of the lawn tractor so you can work under it.
4. Remove the transmission panel by removing the parking brake knob and truss machine screws.
5. Raise the seat. Disconnect the battery cables. Remove the battery and battery box from the unit.
6. Disconnect the idler pulley spring which is attached to a bracket on the frame, inside the left rear wheel. Use a spring puller or other suitable tool.
7. Remove the three self-tapping screws from the cooling fan. Remove the fan.

8. Remove the four self-tapping screws which hold the belt keeper assembly to the frame at the engine pulley. Remove the belt keeper assembly.
9. Roll the belt off the top sheave of engine pulley, onto the pulley hub.
10. Remove the belt from the transmission pulley and engine pulley, and remove from the unit.
11. Reassemble using a new belt, following instructions in reverse order.

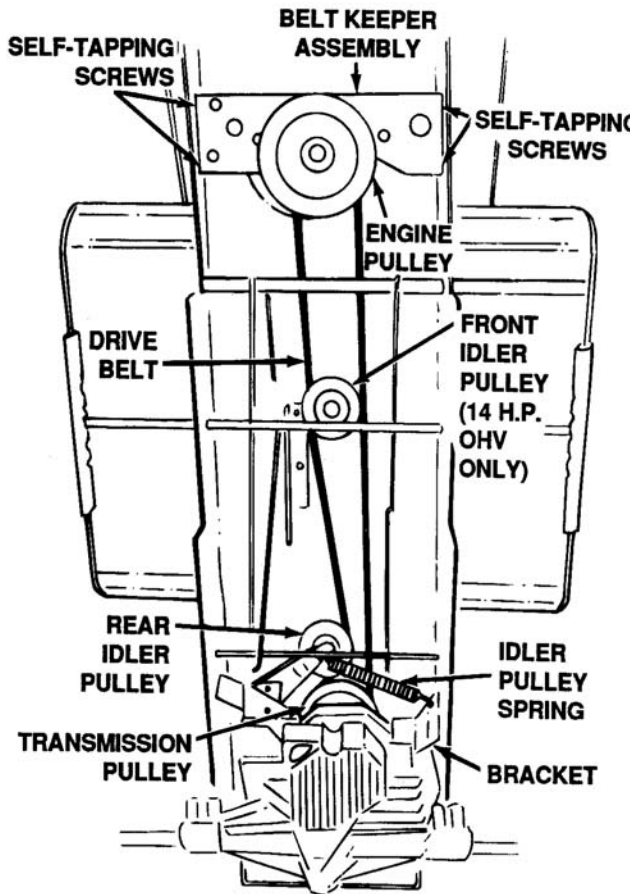


Figure 7-40. Drive Belt

### GEAR DRIVE 700 SERIES.



### CAUTION

You must depress the clutch/brake pedal and come to a complete stop before shifting gears or you will round the keys in the transmission and need service.

**Gearshift Lever.** The transaxle has five forward gears, neutral and reverse. Do not shift through the gears on the transaxle as you would in an automobile. Preselect the gear

appropriate for the job you are doing. See Figure 7-45. Page 7-28.

### SPEED CONTROL ADJUSTMENT



*When operating the unit initially or after replacing the belts, there will be little difference between the highest two speeds until after the belts have gone through a break-in period and have seated themselves into the pulleys.*

If the full range of speeds cannot be obtained on your unit, adjust the speed control as follows.

1. Adjust the speed control lever by pushing the clutch-brake pedal forward until the stop on the brake rod is against the frame. Have another person hold the pedal in this position as you make the following adjustment. Place the speed control lever in parking brake position. Remove the hair-pin clip and flat washer, and adjust the ferrule on the rod so it is against the back end of the slot. Then lengthen rod one more turn. Reassemble and secure with the flat washer and hairpin clip. See Figure 7-41.

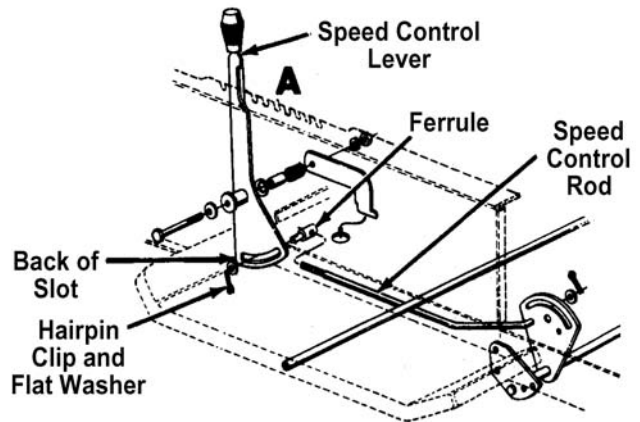


Figure 7-41. Speed Control

2. Adjust the speed control link as follows to obtain the correct neutral adjustment.
  - A. Start the engine.
  - B. Place the shift lever in Neutral position.
  - C. Place the speed control lever in high speed position.
  - D. Release the clutch-brake pedal completely, then slowly depress the pedal all

the way (to park position). Hold the pedal in this position.

- e. Turn the engine off.
- f. After engine stops completely, release the clutch-brake pedal.
- g. Place speed control lever between first and second position (hold in this position).
- h. Remove the cotter pin and flat washer which secures the speed control link to the variable speed torque bracket assembly.
- i. Push the clutch-brake pedal backward by hand as far as it will go using light pressure. Hold it in this position as you thread the speed control link in or out of the ferule until it lines up with the pin on the variable speed torque bracket assembly.
- j. Secure speed control link to variable speed torque bracket assembly with flat washer and cotter pin.

## REAR DRIVE BELT

1. Place shift lever in neutral position. Unscrew the shift knob and the speed control knob (if located on the console). Remove the two truss head screws which secure the transmission cover. See Figure 7-42.
2. Lift the transmission cover. Unplug the safety wire from beneath the transmission cover. Remove transmission cover.
3. Remove the two screws and hex nut from the variable speed bracket assembly. Remove bracket assembly.

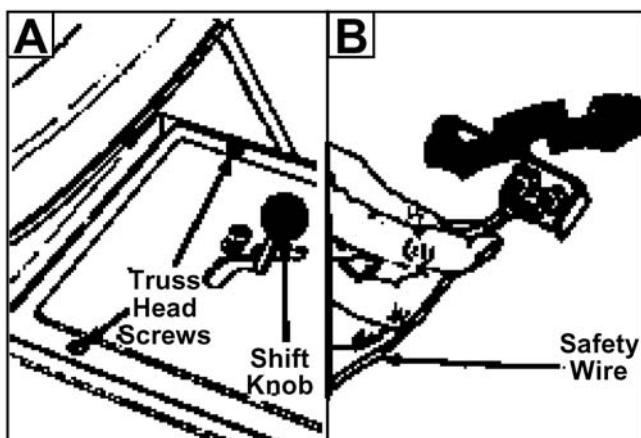


Figure 7-42. Rear Drive Belt

4. Push the idler pulley toward the right side of the unit. Lift the belt over the idler pulley. See Figure 7-43

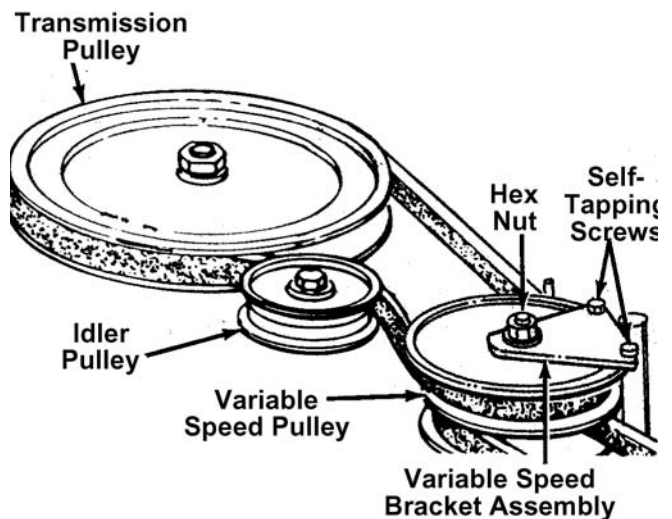


Figure 7-43. Front Drive Belt Removal

5. Remove the belt from the variable speed pulley.
6. Remove the belt from the transmission pulley.
7. Replace belt, and reassemble in reverse order.
8. Adjust the speed control as instructed previously.

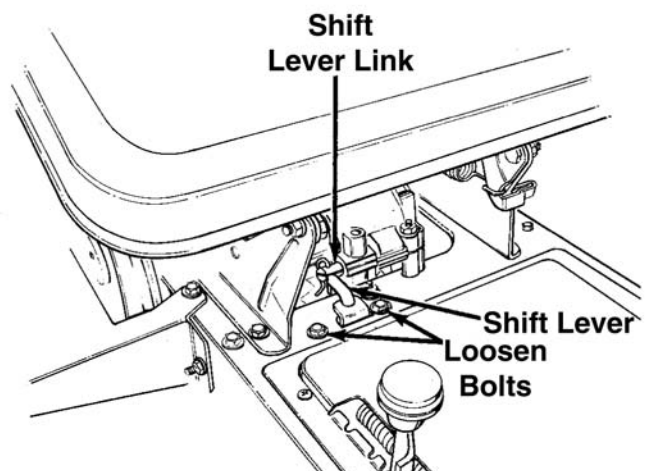


Figure 7-44. Neutral Adjustment

## NEUTRAL ADJUSTMENT

1. Place the transmission in neutral. (The unit will move freely when pushed forward and backward with the parking brake released.)

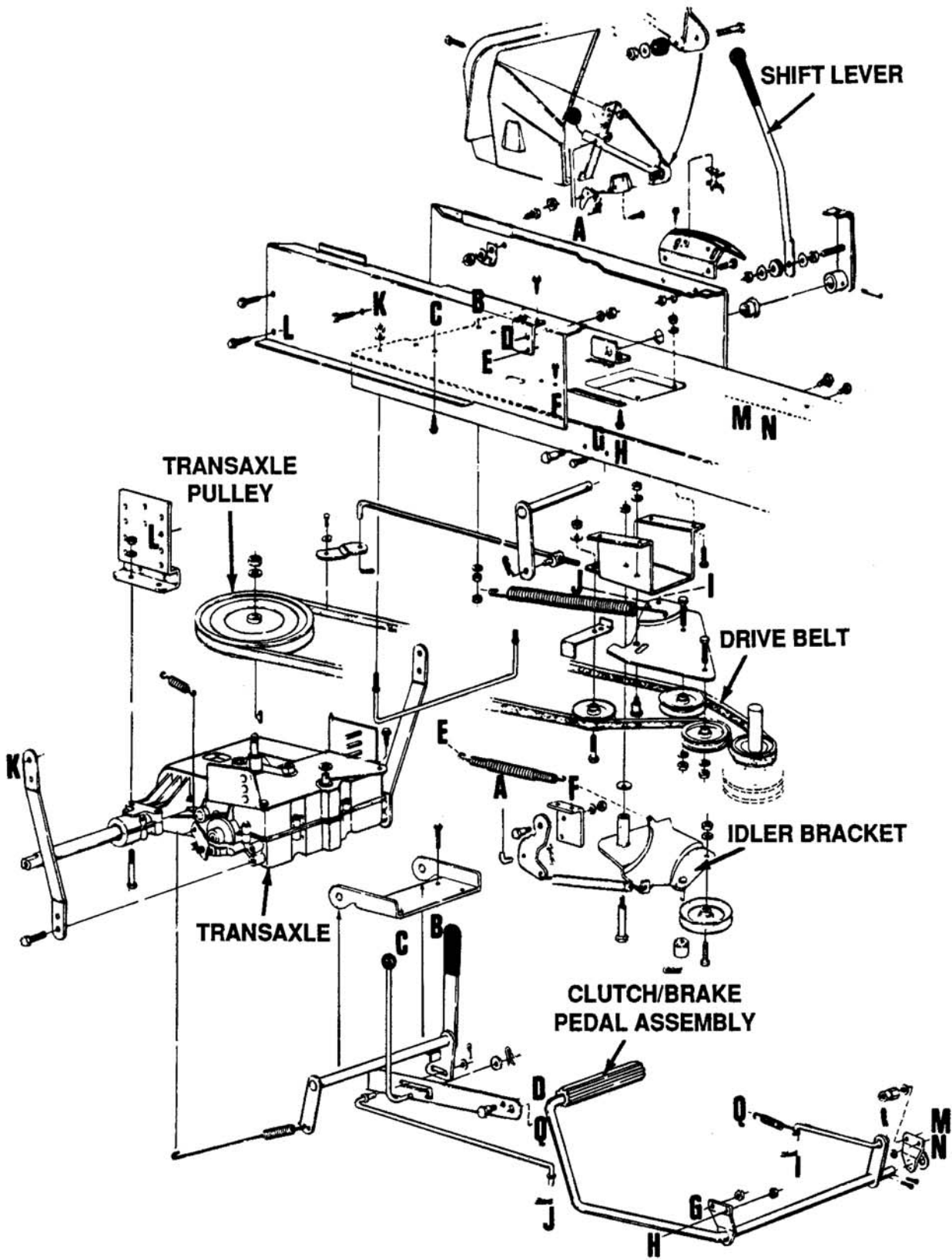
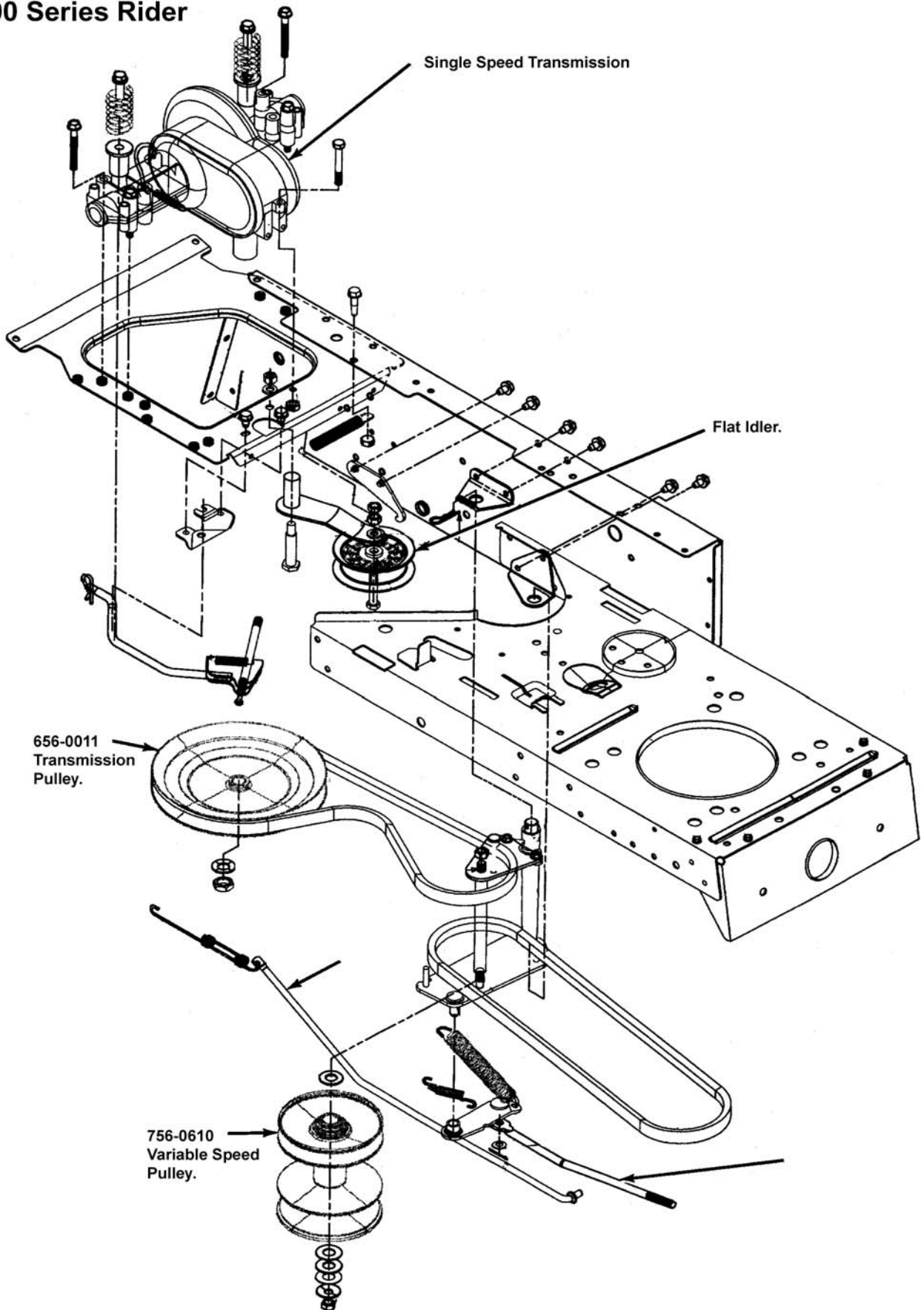


Figure 7- 45. Gear Drive 700 Series

# 700 Series Rider



7

Figure 7-46. 700 Series Rider

2. Loosen the bolts which secures the shift lever assembly to the shift lever link.
3. Place the shift lever in the neutral slot. Retighten the bolts.

### WHEEL ADJUSTMENT

The caster (forward slant of the king pin) and the camber (tilt of the wheels out at the top) require no adjustment. Automotive steering principles have been used to determine the caster and camber on the tractor. The front wheels should toe-in 1/8 inch.

Some units have adjustable tie rods so the toe-in can be adjusted. To adjust the toe-in on these units, proceed as follows.

1. Remove the hex nut and lock washer, and drop the tie rod end from the wheel bracket. Figure 7-47.
2. Loosen the hex jam nut on tie rod.
3. Adjust the tie rod assembly for correct toe-in.

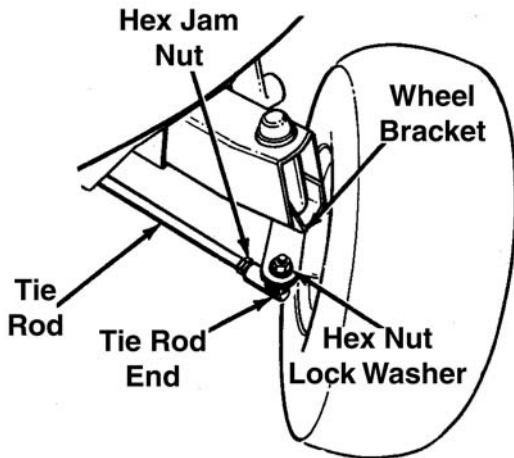


Figure 7-47. Units With Adjustable Tie Rods

Dimension "B" should be approximately 1/8" less than Dimension "A."

- a.) To increase Dimension "B," screw tie rod into tie rod end.
- b.) To decrease Dimension "B," unscrew tie rod from tie rod end.
- c.) Reassemble tie rod. Check dimensions. Readjust if necessary. See Figure 7-48.

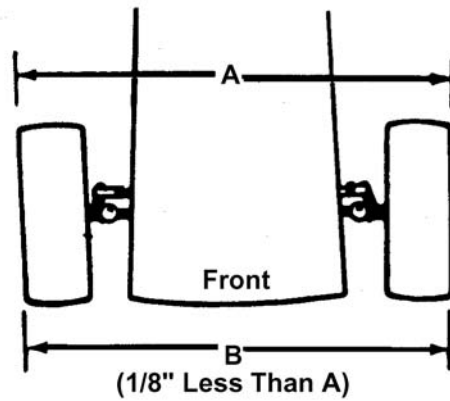


Figure 7-48. Units With Adjustable Tie Rods



### WARNING

**Do not have the engine running when you adjust the brake.**

### BRAKE ADJUSTMENT

To adjust the brake, adjust the nut so the brake starts to engage when the brake lever is 1/4" to 5/16" away from the axle housing. An access hole is provided in the seat mounting bracket. See Figure 7-49.

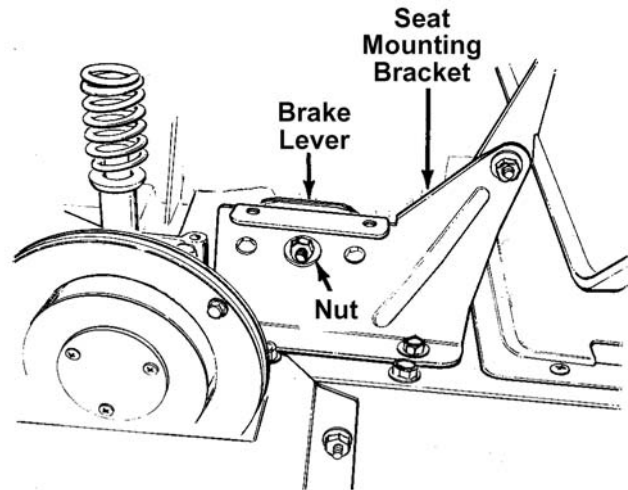


Figure 7-49. Brake Adjustment

The brake is located on the right side, under the seat. During normal operation of this machine, the brake is subject to wear and will require periodic examination and adjustment.

## FRONT DRIVE BELT

1. To remove the front drive belt, first remove the rear drive belt from the idler pulley and variable speed pulley.
2. Place the lift lever in the BLADES OFF position.
3. Remove the belt keeper pins from the engine pulley belt guard.

**NOTE**

*Make certain belt keeper pins are reassembled.*

4. Unhook the deck belt from the engine pulley.
5. Remove the two self-tapping screws on each side of the frame which hold the engine pulley belt guard to the frame. Remove the engine pulley belt guard by slipping it forward and down. See Figure 7-50.

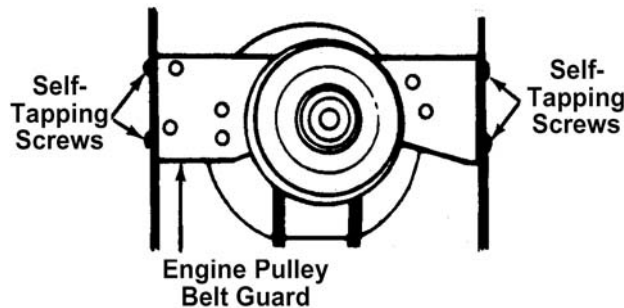


Figure 7-50. Engine Pulley Belt Guard

6. Place the clutch-brake pedal in park position.
7. Push forward on the variable speed pulley, and lift the belt off the engine and remove the belt from the engine pulley.
8. Release the clutch-brake pedal. Using the pedal to move the variable speed pulley as necessary, lift the belt up and off the variable speed pulley. See Figure 7-51.

**NOTE**

*When reassembling, make certain belt is inside the pins.*

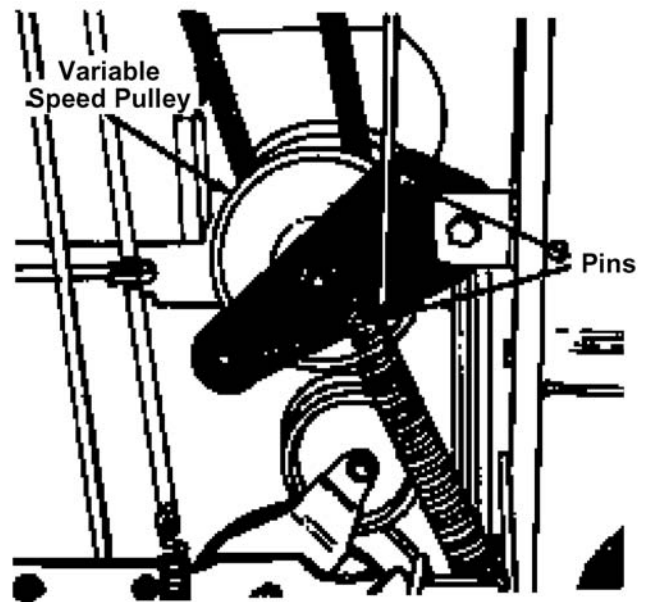


Figure 7-51. Belt Reassembly

9. Reassemble with a new belt, following instructions in reverse order.
10. Adjust the speed control as instructed previously.

**Belt Removal and Replacement With Electric Clutch.** It is not necessary to tip the unit to remove the belts. However, if tipping the unit is desired, remove the battery from the unit. To prevent gasoline leakage, drain the gasoline, or remove the fuel tank cap, place a thin piece of plastic over the neck of the fuel tank and screw on the cap. Be certain to remove the plastic when finished changing the belts. Block unit securely. Replace belts as follows:

**NOTE**

On early 1990 units with an electric clutch, if the unit fails to stop under a heavy load, order a new drive belt (part number 754-0358A). Also, the pitch of the engine pulley may be too narrow causing the belt to bind. Order a new engine pulley using the same part number that is in the Owner's Guide.



**WARNING**

Disconnect the spark plug wire and ground it against the engine. Block the wheels of the unit.



1. Rear drive belt. Remove and replace rear belt as follows:
  - a. Unscrew parking brake knob. Remove the two truss head screws which secure the transmission cover. Remove transmission panel.
  - b. Disconnect the speed selector rod from the variable speed pulley by removing the cotter pin and flat washer and lifting rod off the 3/8 inch pin. See Figure 7-52.

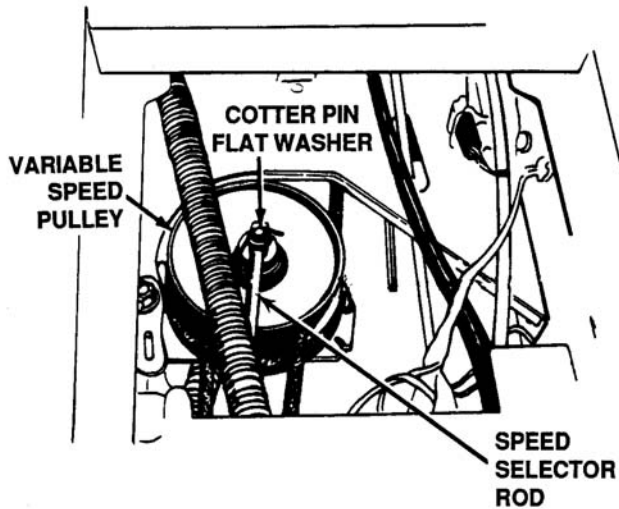


Figure 7-52. Location of Speed Selector Rod

- c. Push the idler pulley toward the right side of the unit. Lift the belt over the idler pulley.
  - d. Remove the belt from the variable speed pulley and transmission pulley.
  - e. Replace belt and reassemble in reverse order.
2. Front belt drive. Remove and replace front belt as follows:
  - a. To remove the front drive belt, first remove the rear drive belt from the idler pulley and variable speed pulley.
  - b. Use the lift lever to raise the deck to its highest position.
  - c. Disconnect the spring from the transmission support bracket using a spring puller. See Figure 7-53.

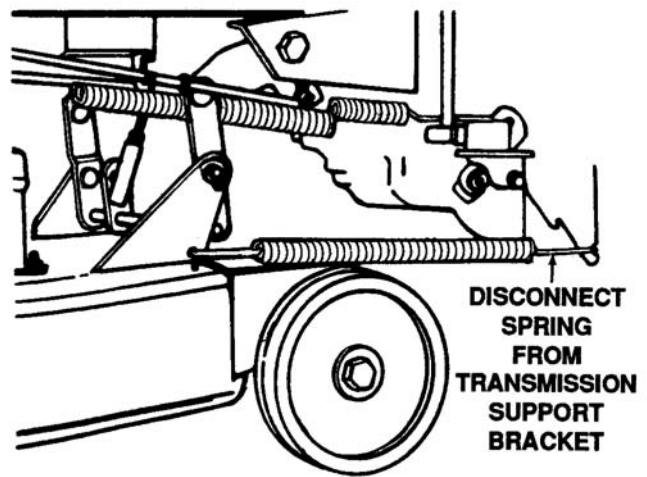


Figure 7-53. Transmission Support Bracket

- d. Unplug the electric PTO.
  - e. Remove the torque bracket by removing two hex bolts and washers. See Figure 7-54.

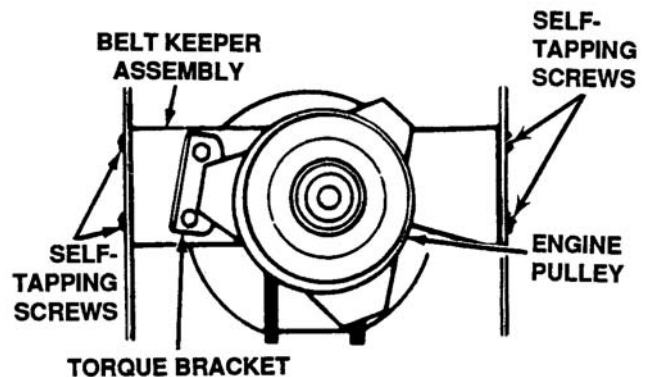


Figure 7-56. Removal of Torque Bracket

- f. Remove the belt keeper assembly by removing the four self-tapping screws which hold the belt keeper assembly to the frame at the engine pulley.
  - g. Loosen the pin at the idler pulley and remove the electric clutch by removing the center bolt and washer. See Figure 7-55.



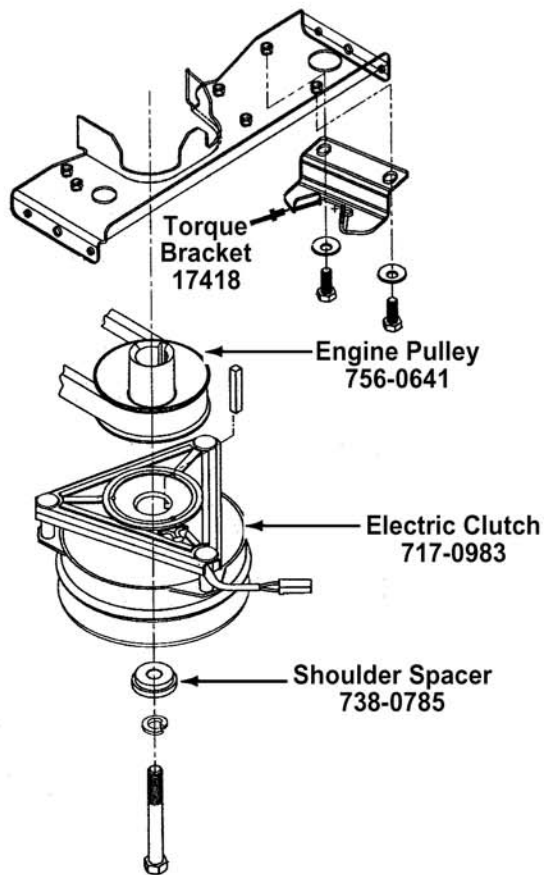
**CAUTION**

Be careful not to drop the electric clutch as it is heavy.

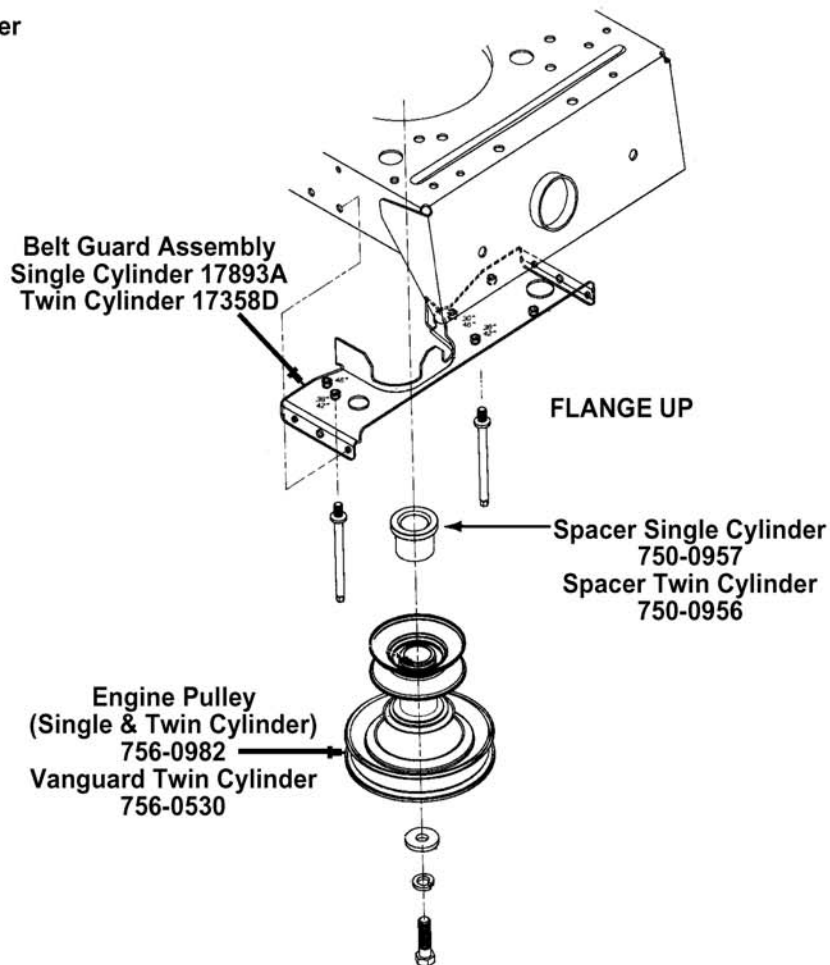
- h. Place the clutch/brake pedal in park position. Remove the belt from the engine pulley.

# Models 760 thru 769

FOR MODELS 760 THRU 769 LAWN TRACTORS



FOR MODELS 760 THRU 769 LAWN TRACTORS



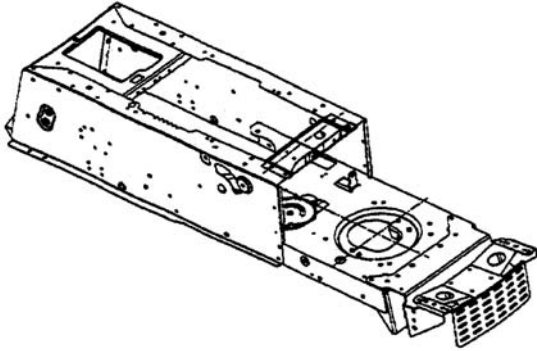
7

Figure 7-55. Models 760 thru 769

- i. Move the variable speed pulley as necessary in order to remove the belt.

**➔ NOTE**

When reassembling, make certain belt is inside the pins. See Figure 7-56.



**Figure 7-37. 600 Series Frame Identification**

- j. Reassemble with a new belt following instructions in reverse order.
- k. Check the adjustment of the speed control as instructed.

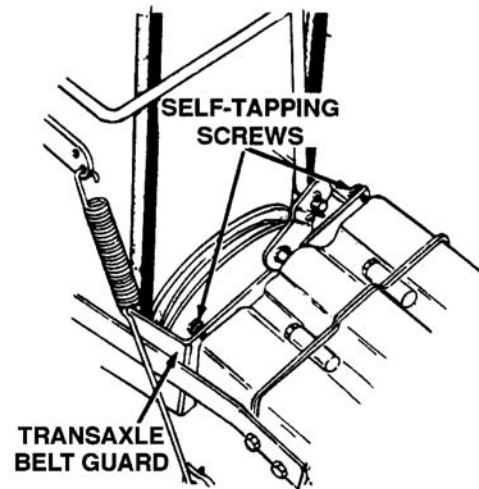
**Clutch/Brake Pedal.** The clutch/brake pedal is located on the right side of the tractor. Depressing the clutch/brake pedal part way disengages the clutch. Pressing the pedal all the way down disengages the clutch and engages the disc brake.

**➔ NOTE**

The clutch/brake pedal must be depressed to start the engine.

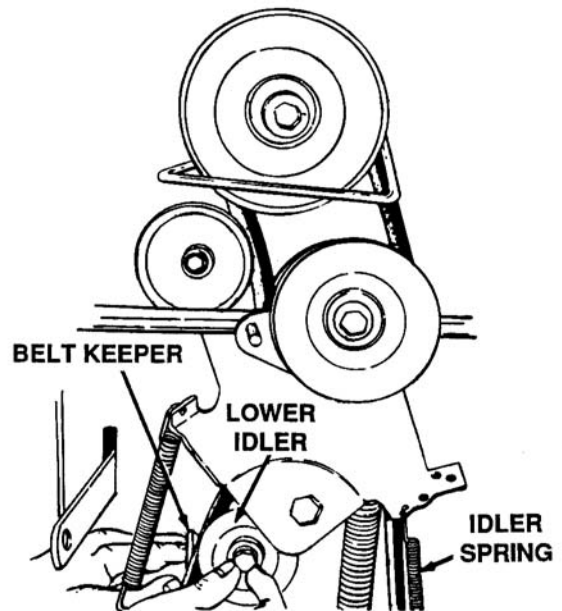
**Changing the Drive Belt.** Change belt as follows:

1. If a cutting deck is attached to your tractor, remove it. Remove the battery.
2. Depress the clutch pedal and set the parking brake.
3. Raise and block the front wheels of the tractor so you can work under it.
4. Remove the transaxle belt guard by removing the two self-tapping screws. See Figure 7-57.



**Figure 7-57. Changing Drive Belt**

5. Unhook the V-belt from the transaxle pulley.
6. Remove the lower idler by taking out the center bolt and nut. See Figure 7-58.



**Figure 7-58. Removing Lower Idler and Spring**

**➔ NOTE**

When reassembling the idler be sure to place the belt keeper in the correct position.

7. Unhook the idler spring so the idler will swing out of your way.
8. Remove the cotter pin from the clutch shaft and pull it out of the bracket. See Figure 7-59.

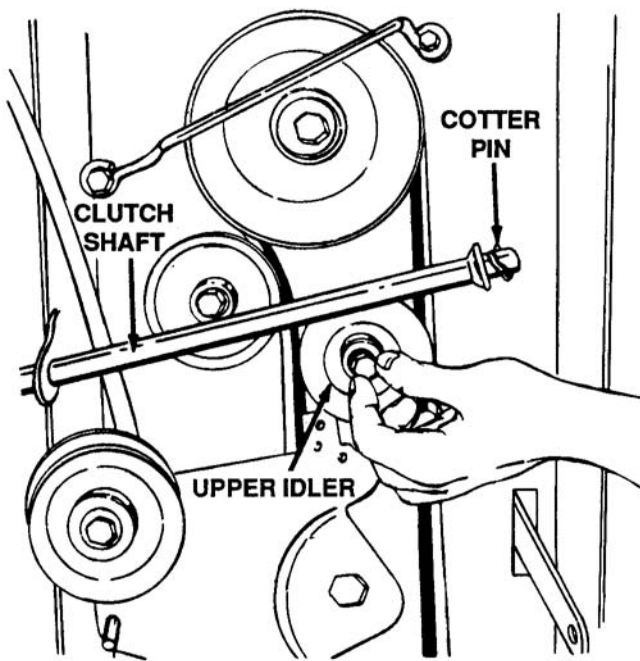


Figure 7-59. Removing Cotter Pin and Idler

9. Remove the upper idler.
10. Remove the cotter pin from the transaxle shifting rod and pull it out of the bracket. See Figure 7-60.

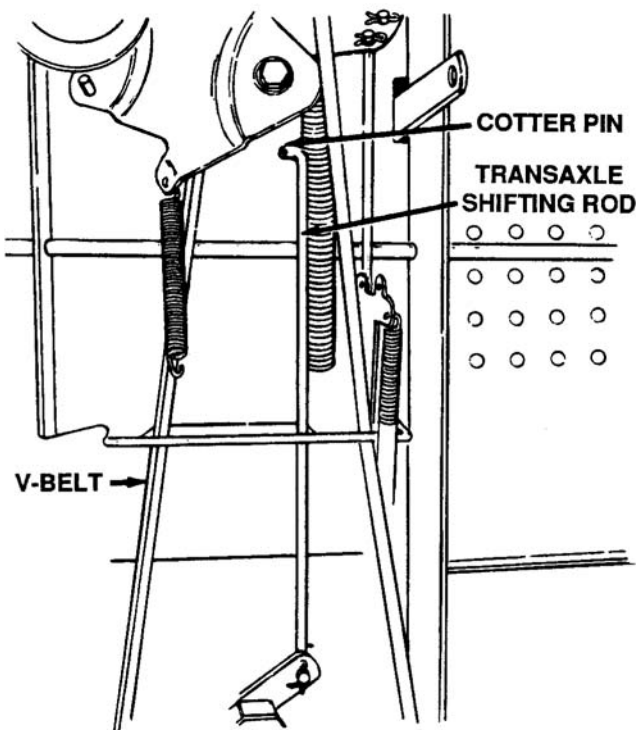


Figure 7-60. Removing Transaxle Shifting Rod

11. The drive belt can now be removed.

12. Reassemble the new belt in reverse order.

## HYDROSTATIC DRIVE 700 SERIES.

This 700 series drive system has a heavy-duty transaxle, part number 717-0950, coupled with a Sundstrand hydrostatic pump, part number 717-0940. They provide even running on all terrain with smooth increase or decrease of speed in either forward or reverse. A cooling fan for the hydro-pump is constantly driven by the engine by mounting it on the transmission input shaft. The hydrostatic pump also has a built-in self seeking neutral which allows the speed lever and hydrostatic pump to return to neutral when the clutch/brake pedal is depressed. See Figure 7-62.

### ➔ NOTE

There have been problems with the hydrostatic control lever creeping back into the neutral position, possibly on an incline. The solution for this is to tighten the hex nut on the pintle arm extension plate 1/4 turn at a time until proper tension is achieved.

**Relief Valve.** A hydrostatic relief valve is provided so the unit can be moved without the engine running. The lever which operates the relief valve is located on the console. To operate the relief valve, place the hydrostatic control level in neutral, release the parking brake, push the lever forward and to the right to lock. Be certain to release the lever by pushing it to the left before operating the engine. See Figure 7-62.

**Clutch/Brake Pedal.** The clutch/brake pedal is located on the left side of the tractor. Depressing the pedal disengages the engine from the hydrostatic transmission and applies the brake. You can release the clutch pedal and resume the same speed without moving the hydrostatic control level.

**Parking Brake.** To set the parking brake, depress the clutch/brake pedal and pull up the parking brake knob. It will stay in the raised position. To release the parking brake, depress and release the clutch/brake pedal.

**Transaxle.** The transaxle is lubricated and sealed at the factory and does not require checking. If disassembled for any reason, lubricate with 16 oz. of grease, part number 737-3047.

**Cold Weather Starting Kit.** A cold weather starting kit is available to disengage the drive belt to provide easier starting for the hydrostatic transmission when the weather is cold. Order part number 753-0509.

**The drive system consists of the following:**

1. V-belt from the engine pulley to the jackshaft. This V-belt is twisted. If the V-belt is twisted the wrong way the tractor will move in reverse when the hydrostatic control lever is in the forward position. The jackshaft is spring loaded and can be pulled forward to remove the V-belt.
2. Clutch V-belt from the jackshaft to the hydrostatic transmission. This is a clutching V-belt. When the clutch pedal is depressed this V-belt goes slack and disengages the engine drive to the hydrostatic transmission.
3. Hydrostatic transmission drives the rear wheels through the Peerless transaxle.



**CAUTION**

This is a lawn tractor, not a garden tractor. It is not designed for ground engaging equipment such as a mold board plow. Using the tractor for purposes for which it was not designed can cause excessive overheating and result in considerable damage to the hydrostatic transmission.

**Conditions which can cause overheating are as follows:**

1. Insufficient amount of fluid (oil level should be kept to the cold mark on the reservoir/expansion tank).
2. Contamination of fluid (if natural color of the transmission fluid has changed black or milky it should be drained and replaced with new transmission fluid).
3. Air in the system (remove the vent plug located next to the reservoir/expansion tank to bleed the system).
4. The hydrostatic transmission is cooled by the oil, fan and fins. (Check to see if the fan is in operating condition, the oil level is correct and the oil is clean.)

**NOTE**

On 1982 units where an overheating condition exists, and all the above conditions have been checked, it may be necessary to make the following modifications to correct the problem.

1. Cut an opening in the right-hand side panel to provide more air circulation (a template is available through the service department).
2. Replace the original transaxle pulley and fan with the revised pulley which has increased blade pitch to improve air flow. Order part number 756-0364.

All 1983 to current production units will have these modifications.

Check the neutral adjustment as follows:

1. Place the hydrostatic control lever in the forward position.
2. Depress the clutch pedal all the way. (The lever should move into the neutral position.)
3. Place the hydrostatic control lever in the reverse position.
4. Depress the clutch pedal all the way. (The lever again should move into the neutral position.)

**Perform neutral adjustment as follows:**

1. Loosen the lock nut on the neutral return rod. Disconnect the ferrule on the neutral return rod from the speed selector handle bracket. See Figure 7-61.

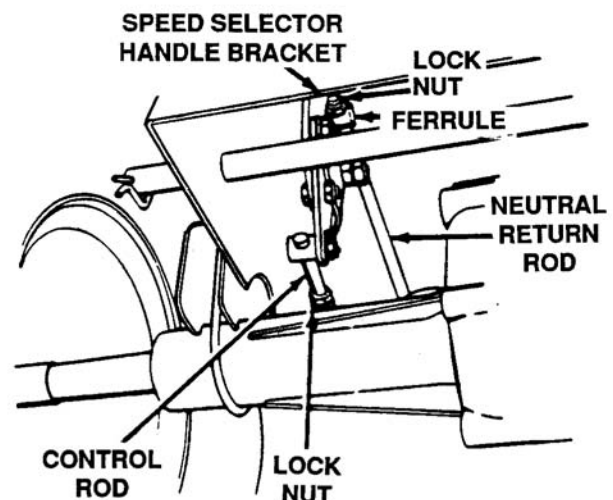


Figure 7-61. Adjustment of Neutral Return Rod

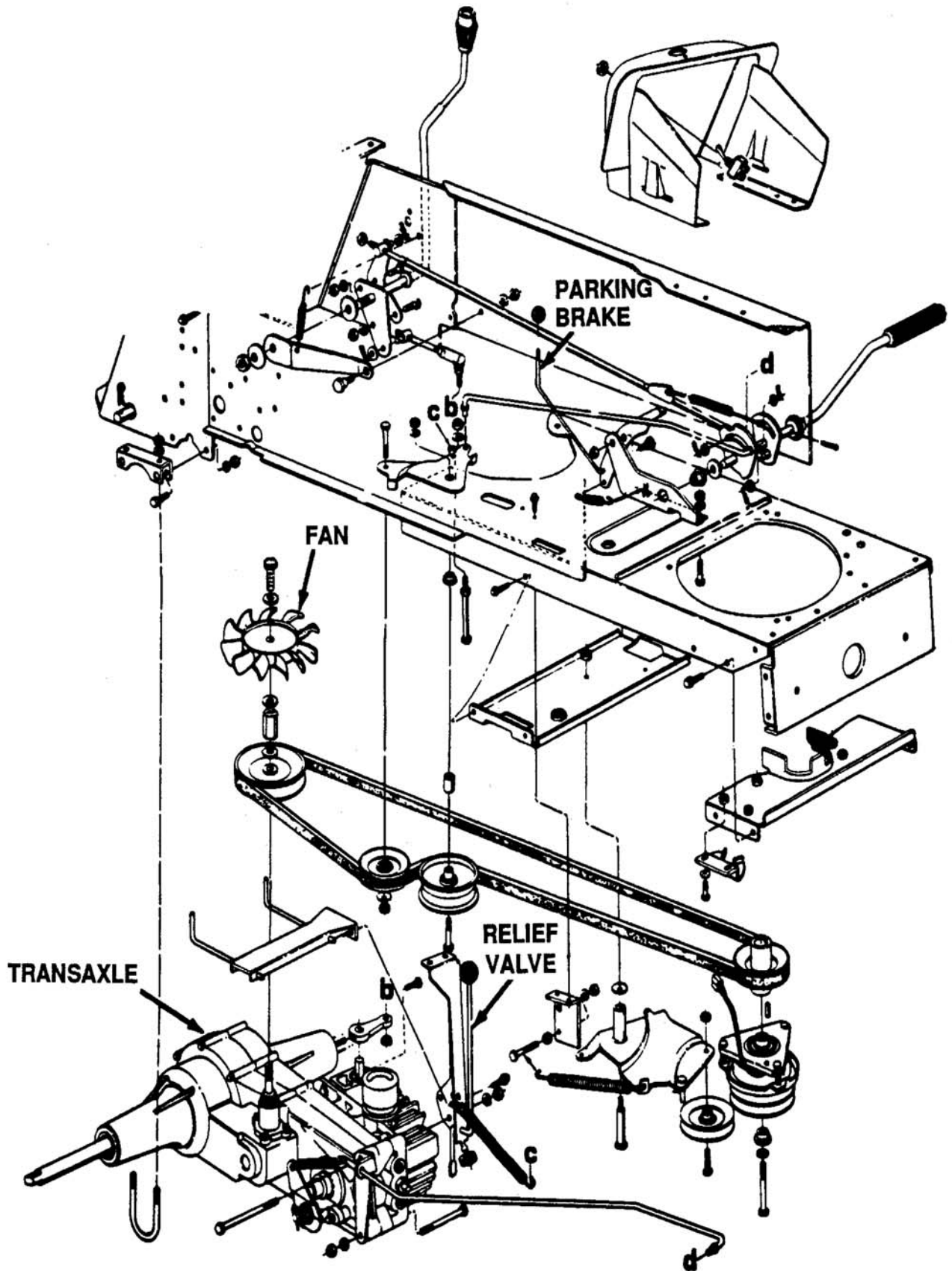


Figure 7-62. Hydrostatic Drive 700 Series

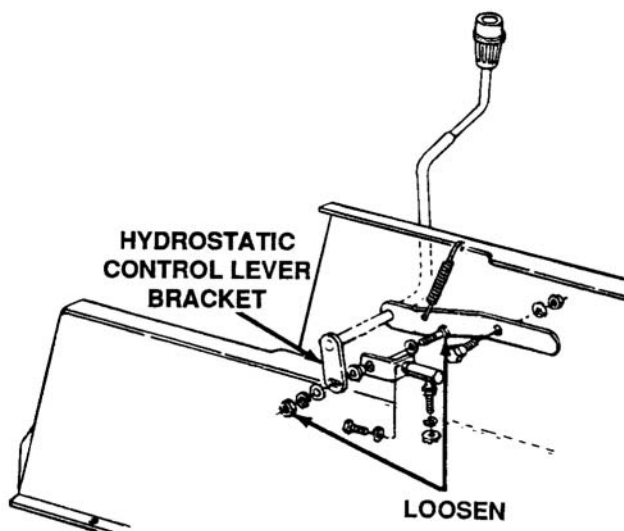
2. With the clutch/brake pedal depressed, place the hydrostatic control lever in neutral.
3. Adjust the ferrule on the rod until it lines up with the hole in the speed selector handle bracket.
4. Reassemble the ferrule to the speed selector handle bracket. Tighten the lock nut against the ferrule.
5. Check the adjustment of the hydrostatic transmission control.

**Adjust hydrostatic control as follows:**



The hydrostatic transmission control is in correct adjustment when the lawn tractor does not move with the engine running, the clutch engaged and the hydrostatic control lever in the neutral (N) position.

1. Loosen the bolt and nut on the bracket on the

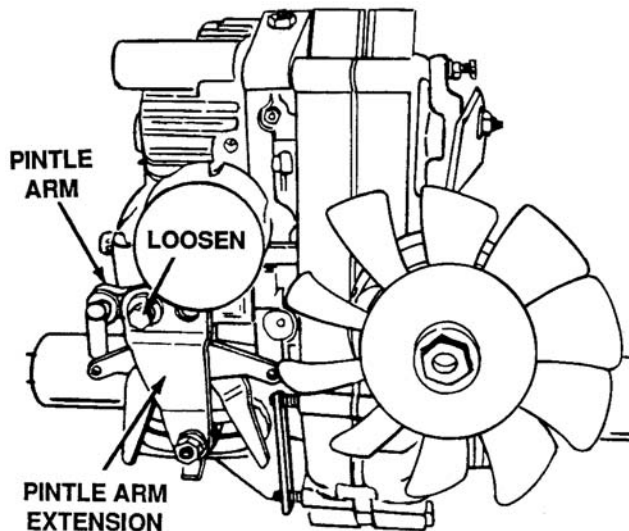


**Figure 7-63. Adjustment of Hydrostatic Control Lever**

hydrostatic control lever. See Figure 7-63

2. Start the engine.
3. Push the clutch/brake pedal all the way forward. Then release the pedal completely. The lawn tractor should not move in either direction. If it does not move, retighten the bolt and nut which secure the hydrostatic control lever. If it does move, shut off the engine and adjust as follows:

- a. Remove the transmission panel. Loosen the hex bolt which secures the pintle arm extension to the pintle arm, using a ratchet wrench with 1/2 inch socket extension. See Figure 7-64.



**Figure 7-64. Adjusting Hydrostatic Control**

- b. Raise both rear wheels off the ground by placing blocks under the rear frame.
- c. Start the engine.
- d. Depress the clutch/brake pedal all the way and set the parking brake.
- e. Move the hydrostatic control lever to move the pintle arm until you find neutral (rear wheels do not rotate in either direction).



**WARNING**

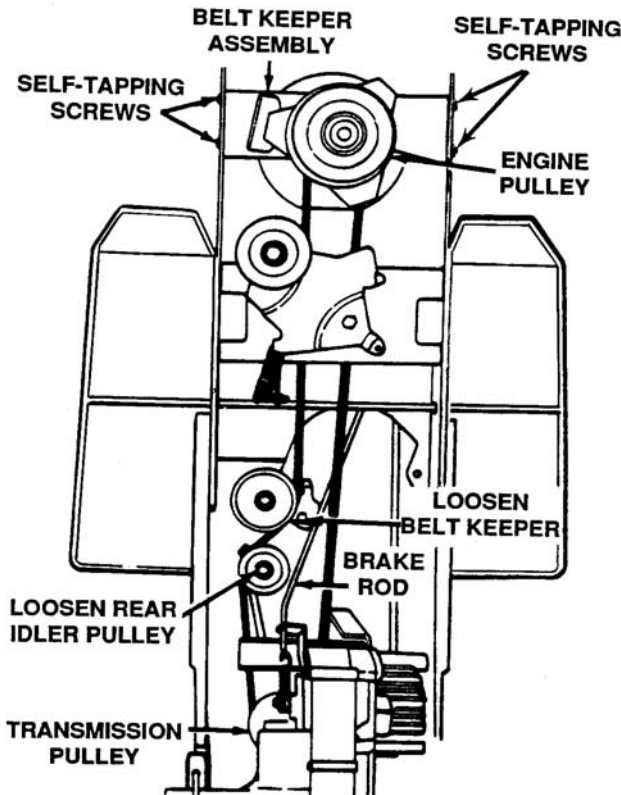
Be careful of the cooling fan on the hydrostatic transmission.

- f. Tighten the hex bolt which secures the pintle arm extension to the pintle arm.
- g. Release the clutch/brake pedal by pushing all the way forward, then releasing the pedal.
- h. Check the wheels for movement. They should not rotate in either direction. If they do, readjust until the wheels do not move.
- i. Adjust the position of the hydrostatic control lever as follows:
  - (1) Shut off the engine.

- (2) Depress the clutch/brake pedal all the way and set the parking brake.
  - (3) Place the hydrostatic control lever in neutral (N).
  - (4) Tighten the bolt and nut on the bracket on the hydrostatic control lever.
- j. Replace the transmission panel.
- k. Remove the blocks from under the frame and test the operation of the lawn tractor.

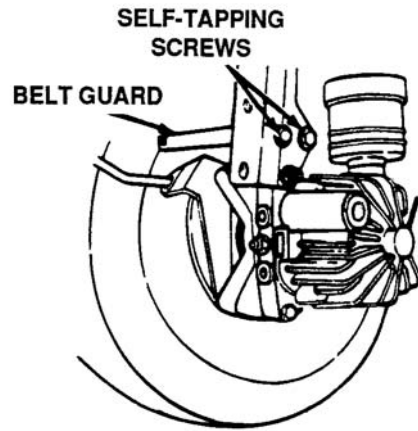
**Drive belt replacement.**

1. Depress the clutch/pedal and set parking brake.
2. Remove the deck from the tractor.
3. Raise and block the front wheels of the tractor so you can work under it.
4. Remove the four self-tapping screws which hold the belt keeper assembly to the frame at the engine pulley. Push the belt keeper assembly forward out of the way. See Figure 7-65.



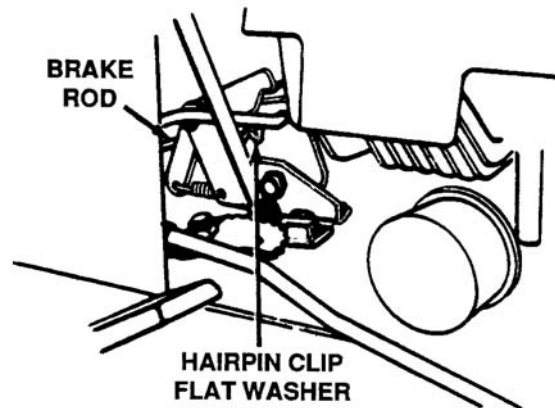
**Figure 7-65. Drive Belt Replacement**

5. Remove the rear belt guard at the transmission pulley by removing the two self-tapping screws. See Figure 7-66.



**Figure 7-66. Removing Rear Belt Guard**

6. Loosen the hex bolt which acts as a belt keeper by the front idler pulley.
7. Loosen the rear idler pulley. Remove the belt from around both idler pulleys. See Figure 7-65.
8. Unplug the electric PTO clutch.
9. Roll belt up off engine pulley onto the pulley hub to obtain slack in the belt.
10. Remove belt from the transmission pulley lifting the belt up over the fan on top of the pulley.
11. Remove belt from the engine pulley.
12. Release the parking brake (be certain unit is blocked securely). Disconnect the brake rod from the clutch/brake pedal by removing the hairpin clip and flat washer. See Figure 7-67.



**Figure 7-67. Disconnecting Brake Rod**

13. Remove the belt from around the brake rod.
14. Reassemble using a new belt and following instructions in reverse order.





# DECK LEVELING

## INITIAL PREPARATION:

**IMPORTANT:** Prior to leveling the mowing deck, perform the following steps:

1. Check the tire pressure. All tires will be approximately 12 PSI.
2. Place the rider on a level surface.
3. Depress and lock the parking brake.
4. Raise the hood and remove the grass bag assembly and discharge chute.
5. Remove the spark plug wire from the spark plug and lower the hood.
6. Raise the cutting height adjustment lever to the highest position.
7. Locate both lower "T" links and extension springs that secure the rear deck hangers to the pivot link assemblies.
8. Make certain the lower "T" links are mounted to the rider correctly. See Figure 8-1.

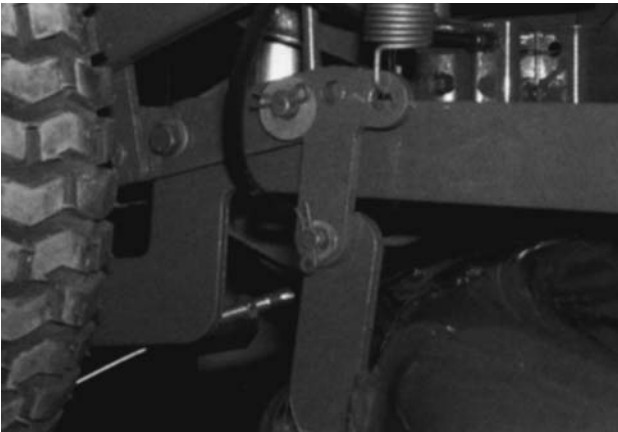


Figure 8-1.

## FRONT TO REAR LEVELING ADJUSTMENT:

**IMPORTANT:** The front of the mowing deck will be between 1/4" and 3/8" lower in the front than the rear of the deck.

1. Using a work glove or rag, rotate the mowing blade until it is parallel with the rider frame. See Figure 8-2.

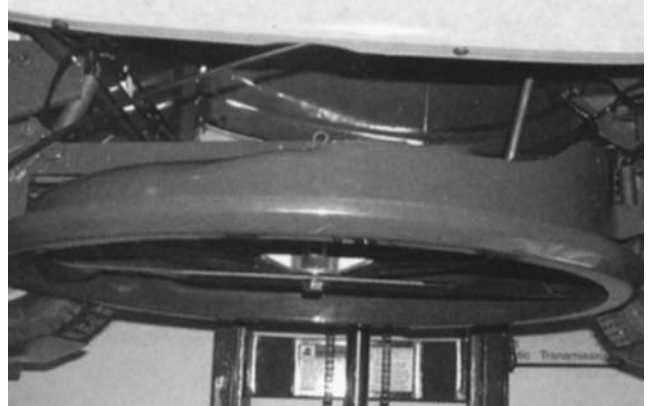


Figure 8-2.

2. Depress and lock the deck pedal assembly.
3. Measure the front blade tip to ground.
4. Measure the rear blade tip to ground.
5. The front blade tip will be 1/4" to 3/8" lower than the rear blade tip. If not, perform the following adjustments:
6. Loosen both jam nuts that are directly on top of the center deck ferrules using a 3/4" wrench. See Figure 8-3.

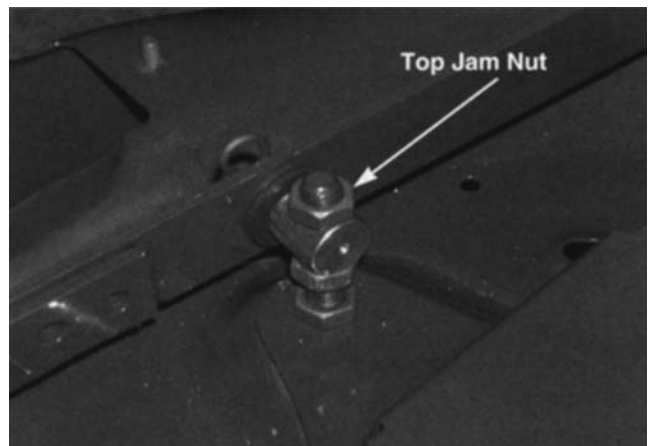
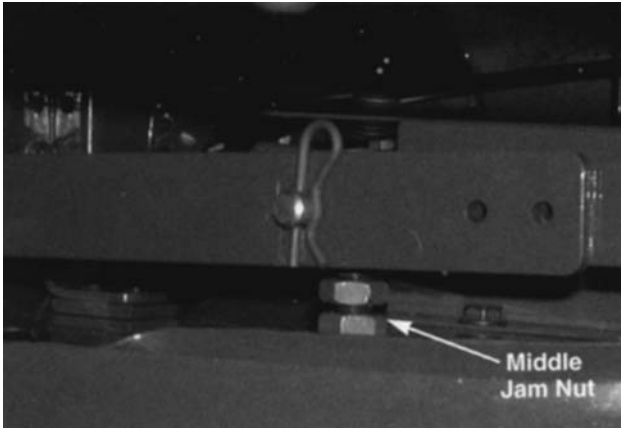


Figure 8-3.

7. Loosen the middle jam nuts that are directly below the center deck ferrules until they bottom out on top of the mowing deck jam nuts using a 3/4" wrench. See Figure 8-4.



**Figure 8-4.**

8. Raise or lower the mowing deck assembly by tightening or loosening the jam nuts that are directly on top of the center deck ferrules, until the proper measurement (front to back) has been achieved. Refer to Figure 8-3.
9. Tighten both middle jam nuts that are directly below the center deck ferrules using a 3/4" wrench.
10. Release the deck pedal assembly.

**SIDE TO SIDE LEVELING ADJUSTMENT:**

1. Using a work glove or rag, rotate the mowing blade until it is perpendicular to the rider frame. See Figure 8-5.



**Figure 8-5.**

2. Depress and lock the deck pedal assembly.

3. Measure the right blade tip to ground.
4. Measure the left blade tip to ground.
5. The right blade tip will be equal to the left blade tip. If not, perform the following steps:
6. Loosen both jam nuts that are directly on top of the center deck ferrules using a 3/4" wrench. Refer to Figure 8-3.
7. Loosen the middle jam nuts that are directly below the center deck ferrules until they bottom out on top of the mowing deck jam nuts using a 3/4" wrench. Refer to Figure 8-4.
8. Identify which side of the mowing deck needs to be raised or lowered to achieve the correct measurements.
9. Locate and adjust the jam nuts that are directly on top of the center ferrules until the deck is leveled out. Refer to Figure 8-3.

**REMEMBER:** The front to back adjustment will be altered if both jam nuts are altered.

10. Tighten both middle jam nuts that are directly below the center deck ferrules using a 3/4" wrench.
11. Release the deck pedal assembly.
12. Reconnect the spark plug wire to the spark plug.
13. Reinstall the discharge chute and grass bag assembly.
14. Lower the hood and test for a level cut.

**Optional high lift blade available**

Blade 942-0578 improves bagging performance.

**Deck Leveling**

Check for the correct orientation of the lower "T" links. The distance from the lower hole to the upper rear hole should be slightly longer than the distance from the lower hole to the upper front hole. Some links may be installed incorrectly. Refer to service bulletin R-445. See Figure 8-6.

## TESTING THE BRAKES:

1. Release the parking brake and place the rider in neutral.
- 2). Depress the brake pedal and try to roll the rider.

### ➡ NOTE

If the tractor moves, perform the following steps:

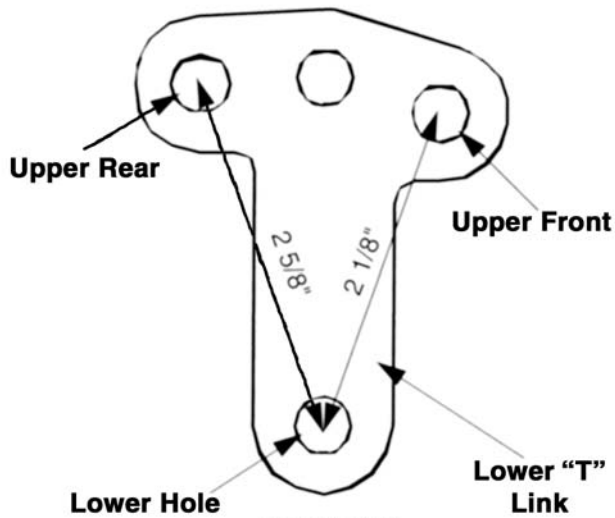


Figure 8-6.

## BRAKE ADJUSTMENT

### BRAKE ADJUSTMENT AT THE TRANSMISSION:

1. Standing on the right side of the rider, locate the brake cable under the front housing.
2. Follow the brake cable forward to the front channel assembly. See Figure 8-7.

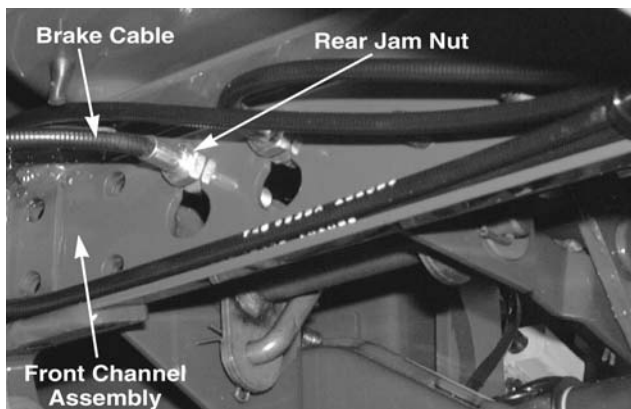


Figure 8-7.

3. Locate and loosen the brake cable adjustment jam nuts using two 1/2" wrenches.
4. By hand, loosen the rear jam nut (closest to the deck) until it bottoms out on the threaded cable end.
5. Slide the brake cable forward until the rear jam nut is flush with the back side of the front channel assembly.

6. By hand, tighten the front jam nut to the front of the front channel assembly. See Figure 8-8.

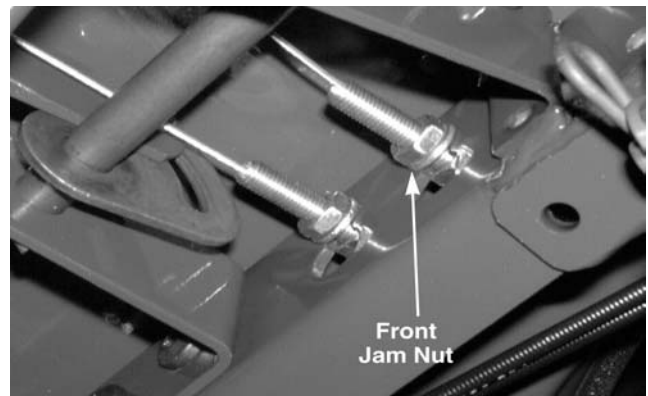


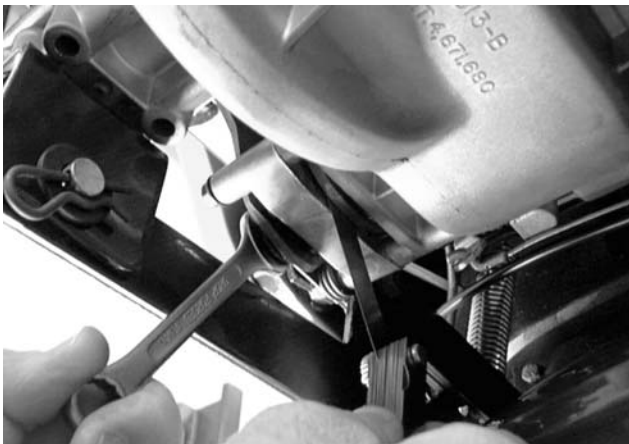
Figure 8-8.

7. Tighten both jam nuts using two 1/2" wrenches.
8. Locate the locking hex nut that secures the brake actuation arm to the brake assembly on the transmission. See Figure 8-9.
9. Loosen (**DO NOT REMOVE**) the locking hex nut using a 1/2" wrench. See Figure 8-9.



**Figure 8-9.**

10. Slide an .011" feeler gauge between the brake disc and the brake puck. See Figure 8-10.
11. Tighten the locking hex nut until the .011" feeler gauge is snug. See Figure 8-10.



**Figure 8-10.**

12. Remove the .011" feeler gauge.
13. Test for proper brake adjustment using the TESTING THE BRAKES section.

**PERIODIC BRAKE ADJUSTMENT:**

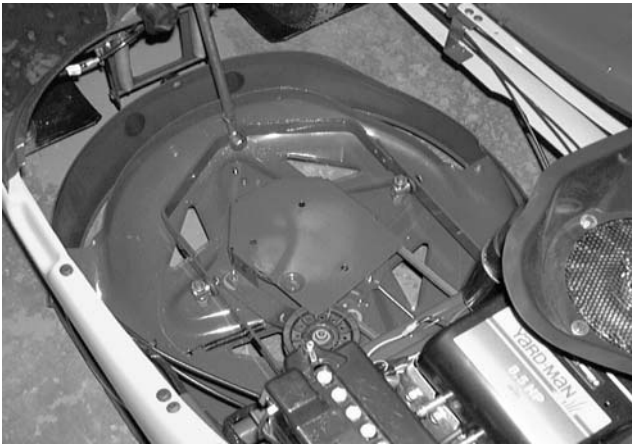
1. Lock the parking brake and turn the ignition key off.

2. Pivot the hood up and remove the spark plug wire from the spark plug.
3. Lower the hood.
4. From the right side of the rider, locate the brake cable under the front housing.
5. Follow the brake cable forward to the front channel assembly.
6. Locate and loosen the brake cable adjustment jam nuts using two 1/2" wrenches. Refer to Figures 8-7 and 8-8.
7. Loosen the front jam nut several turns.
8. Grasp the brake cable with your left hand from the rear of the front channel assembly and gently pull rearward.
9. Tighten the rear jam nut (clockwise) one complete rotation at a time using a 1/2" wrench. Between rotation, try to roll the rider. Refer to Figure 8-7.
10. When the rider no longer rolls, hand tighten the front jam nut to the front of the front channel assembly. Refer to Figure 8-8.
11. Tighten both jam nuts using two 1/2" wrenches.
12. Unlock the parking brake and roll the rider several feet on flat ground to make certain the brakes are not too tight.
13. Repeat the TESTING THE BRAKES section and make certain all hardware is secure.
14. Pivot the hood up, reconnect the spark plug wire, and pivot the hood down.

**IMPORTANT:** The deck belt will begin to engage when the blade engagement pedal is depressed 3/4" from the original starting position.

# BLADE BRAKE/PTO ADJUSTMENT

1. Lower the mowing deck to the lowest cutting position.
2. Raise the hood and remove the grass bag assembly. See Figure 8-11.



**Figure 8-11.**

3. Remove the spark plug wire from the spark plug.
4. Depress the blade engagement pedal 3/4" from the starting position. See Figure 8-12.

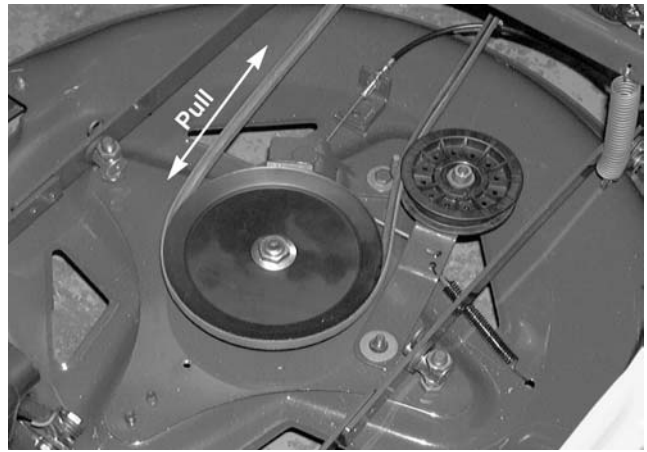
**NOTE**

Use a tape measure from the original starting point of the engagement pedal.



**Figure 8-12.**

5. Take hold of the deck engagement belt and try to pull it forward or backward. See Figure 8-13.

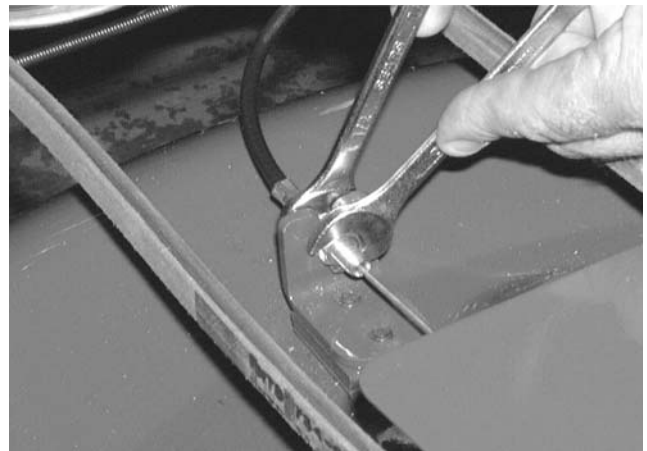


**Figure 8-13.**

**NOTE**

If the belt is slipping through the deck pulley and engagement flat idler, perform the following steps:

6. Release the blade engagement pedal.
7. Locate and loosen the hex jam nuts that secure the threaded end of the deck cable to the deck cable bracket using two 1/2" wrenches. See Figure 8-14.



**Figure 8-14.**

8. Adjust the deck cable to the proper specifications and secure the hex jam nuts using two 1/2" wrenches.
9. Test the blade engagement pedal for proper adjustment by performing steps 4 and 5.

**NOTE**

Make certain the deck belt has a maximum deflection of 1/2" off center when the blade engagement pedal is fully depressed.

# SPEED CONTROL PEDAL ADJUSTMENT

## INITIAL SPEED CONTROL PEDAL ADJUSTMENT WITH NEW BELTS:

### NOTE

This section is performed with new belts **ONLY**.

1. Lock the parking brake and turn the ignition key "OFF".
2. Pivot the hood up and remove the spark plug wire from the spark plug.
3. Lower the hood.
4. From the right side of the rider, locate the variable drive cable under the front housing.
5. Follow the variable drive cable forward to the front channel assembly.
6. Locate and loosen the variable drive cable adjustment jam nuts using two 1/2" wrenches. See Figures 8-15 and 8-16.

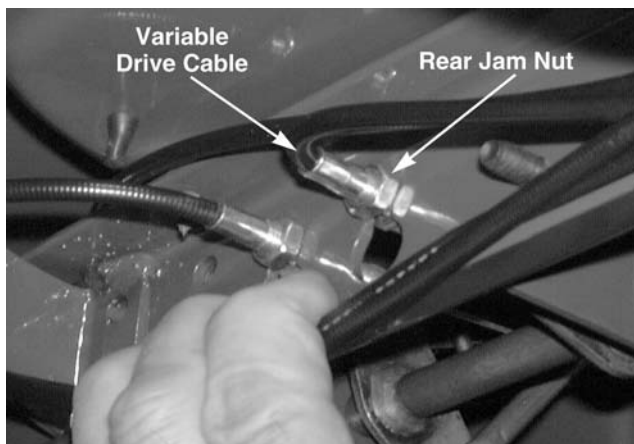


Figure 8-15.

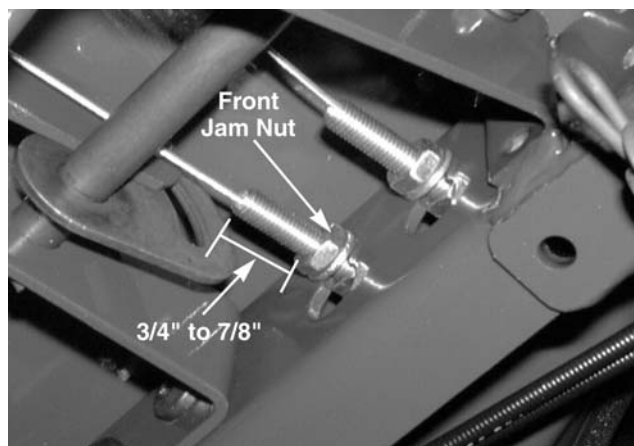


Figure 8-16.

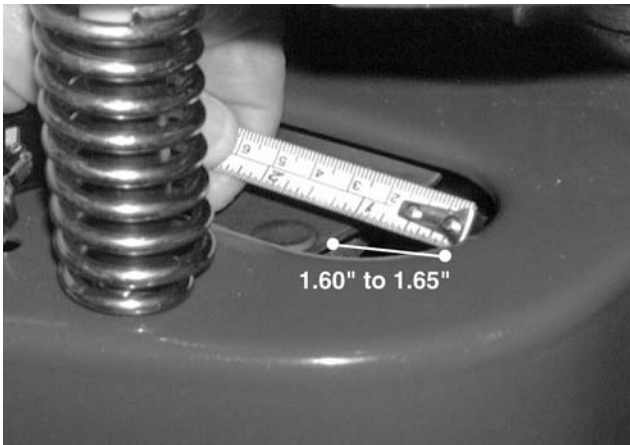
7. By hand, loosen the rear jam nut (closest to the deck) until it bottoms out on the threaded cable end. See Figure 8-15.
8. By hand, tighten the front jam nut until the threaded cable end is exposed 3/4" to 7/8" past the front face of the front jam nut. See Figure 8-16.
9. By hand, tighten the rear jam nut (clockwise) until it is snug up against the rear of the front channel assembly. See Figure 8-15.
10. Tighten both jam nuts using two 1/2" wrenches.
11. Release the parking brake.
12. Apply 10 pounds of force to the variable pedal assembly with a fish scale. See Figure 8-17.



Figure 8-17.

13. From the back of the rider, locate the oval frame extrusion directly behind the engine.
14. Looking down through the oval extrusion, locate the head of the weld pin (belt keeper) on the idler bracket assembly.
15. With a partner applying 10 pounds of force to the variable pedal assembly, measure the distance between the edge of the weld pin head and the right inside edge of the oval extrusion. The measurement will be between 1.60" and 1.65". See Figure 8-18.

**IF ADDITIONAL SPEED CONTROL ADJUSTMENT IS NEEDED, PERFORM THE FOLLOWING STEPS:**



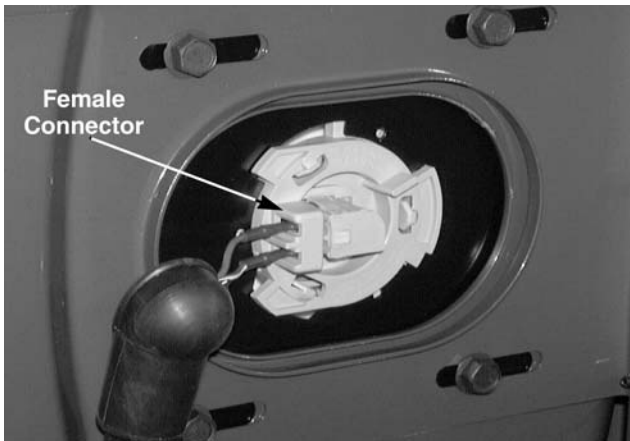
**Figure 8-18.**

**IMPORTANT: DO NOT** perform adjustment while the rider is running.



Inspect both variable drive belts before performing this adjustment.

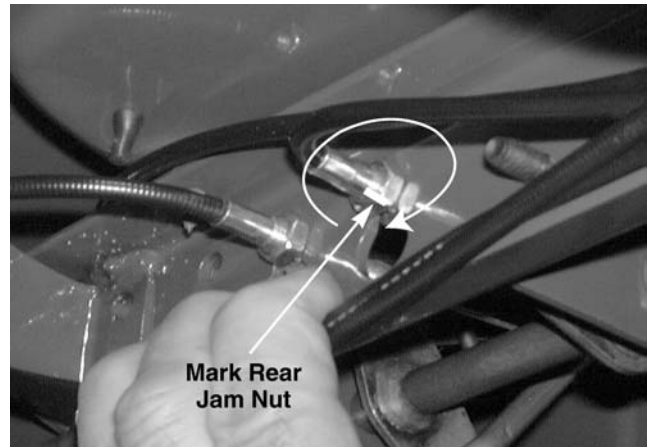
1. Place the rider on level ground and make certain the parking brake is **NOT** applied.
2. Raise the hood, remove one of the wiring harness female connectors from the seat switch, and lower the hood. See Figure 8-19.



**Figure 8-19.**

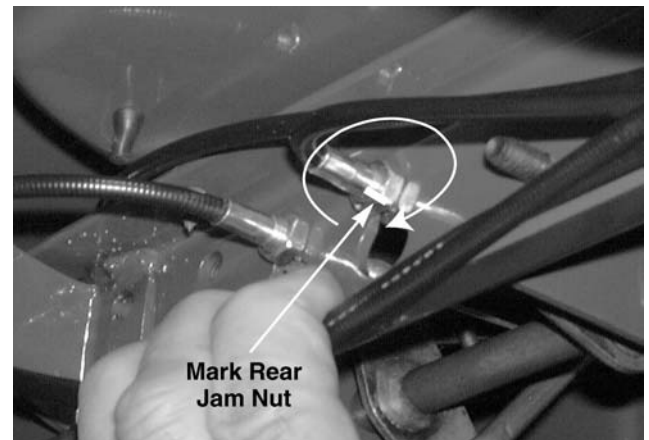
3. Raise the rear wheels of the rider off the ground.
4. From the right side of the rider, locate the variable drive cable under the front housing.
5. Follow the variable drive cable forward to the front channel assembly.

6. Locate and loosen the variable drive cable adjustment jam nuts using two 1/2" wrenches. Refer to Figures 8-15 and 8-16.
7. By hand, loosen the front jam nut several full turns. See Figure 8-20.



**Figure 8-20.**

8. Mark a line at any point on the back face of the rear jam nut. See Figure 8-21.



**Figure 8-21.**

9. Grasp the variable drive cable with your left hand from the rear of the front channel assembly and gently pull rearward.
10. Looking at the line that was marked on the rear jam nut, tighten the rear jam nut 1 complete rotation (clockwise) using a 1/2" wrench.
11. **"START"** the rider.
12. Place the shift lever in the forward position.
13. Make certain the variable drive pedal is fully released.



14. Look at the rear tire assemblies and check for motion.

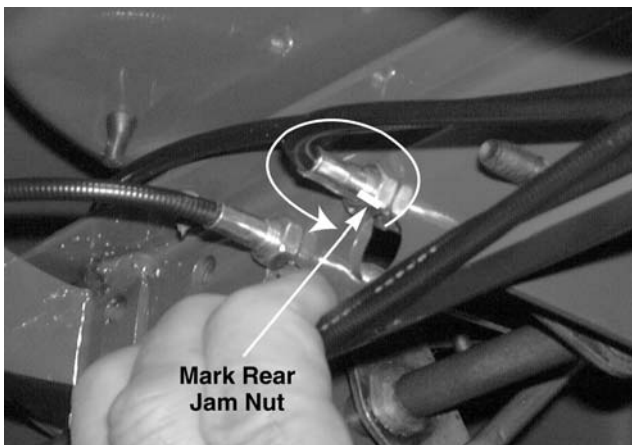
**➡ NOTE**

If any motion is present, shut "OFF" the rider and proceed to step 15.

**➡ NOTE**

If there is NO motion, shut "OFF" the rider and repeat steps 9 through 14.

15. Looking at the line that was marked on the rear jam nut, loosen the rear jam nut 2 complete rotations using a 1/2" wrench. See Figure 8-22.

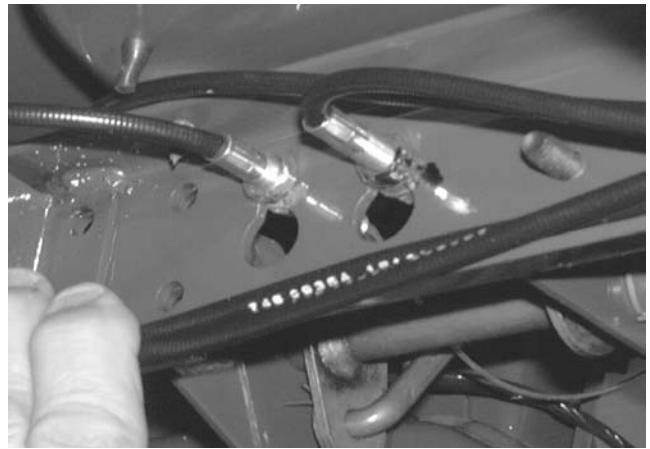


**Figure 8-22.**

16. By hand, tighten the front jam nut to the front of the front channel assembly. See Figure 8-23.



**Figure 8-23.**



**Figure 8-24.**

17. Tighten both jam nuts using two 1/2" wrenches. See Figure 8-24.
18. "START" the rider.
19. Depress and release the variable pedal assembly several times.
20. Fully release the variable pedal assembly and make certain the rear wheels are not trying to rotate.

**➡ NOTE**

If the rear wheels try to move at all, shut the rider "OFF" and back the rear jam nut off 1 full rotation.

21. **IMPORTANT:** Raise the hood, connect the wiring harness female connector (removed earlier) to the seat switch, and lower the hood.

**TEST RUN AND ADJUST IF NECESSARY.**

# STEERING ADJUSTMENT

**IMPORTANT:** The front tires should have a "TOE-IN" between 1/16" and 5/16" to allow the unit to track properly.

1. Check the tire pressure in the front tires and make certain that they are at approximately 12 PSI.
2. Place the unit on level ground.
3. Place the steering wheel in the straight forward position. See Figure 8-25.



Make certain the tires are running parallel with the frame. Figure 8-25



Figure 8-25.

4. In front of the axle, measure the distance horizontally from the inside of the left rim, to the inside of the right rim. See Figure 8-26.

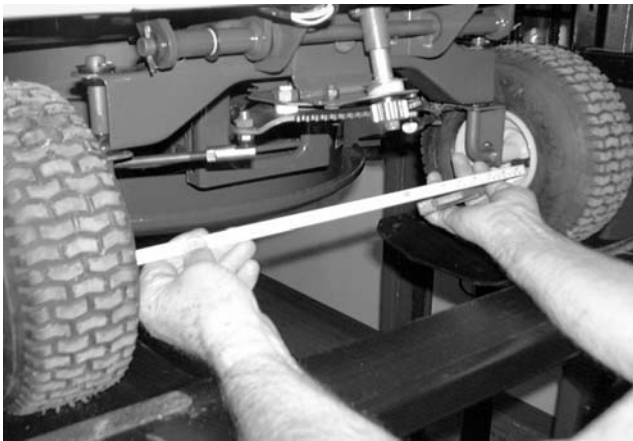


Figure 8-26.

5. From behind the axle, measure the distance horizontally from the inside of the left rim, to the inside of the right rim.
6. The measurement taken in front of the axle should be between 1/16" and 5/16" less than the measurement taken behind the axle. If not, perform the following steps:
7. Remove the hex nut securing the right ball joint to the steering segment gear using a 1/2" and a 9/16 wrench.



Do not lose the lock washer. See Figure 8-27.

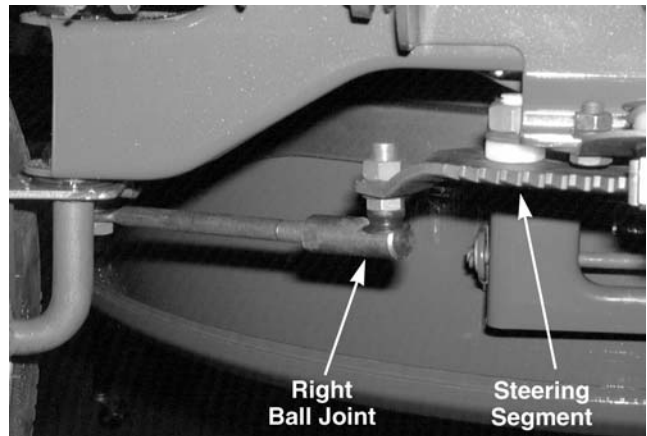


Figure 8-27.

8. Remove the hex nut securing the left ball joint to the steering segment gear using a 1/2" and a 9/16 wrench.



Do not lose the lock washer.

9. Remove both ball joints from both tie rods using a 1/2" wrench.
10. Place the left and right tire assemblies in the straight forward position.
11. Set the toe-in for the rim assemblies to the proper measurements as described in steps 4, 5, and 6.
12. Thread the right hand ball joint onto the right hand tie rod until the mounting hole in the steering segment gear lines up with the ball joint stud.

**➔ NOTE**

Count the number of turns the ball joint rotates onto the tie rod. The number of rotations will be equal to the left side.

13. Secure the right hand ball joint to the steering segment gear with the hex nut removed earlier using a 1/2" and a 9/16 wrench.

**➔ NOTE**

Make certain the lock washer is between the ball joint and the steering segment gear. 14.

Install the left hand ball joint to the tie rod and steering segment gear performing steps 12 and 13.

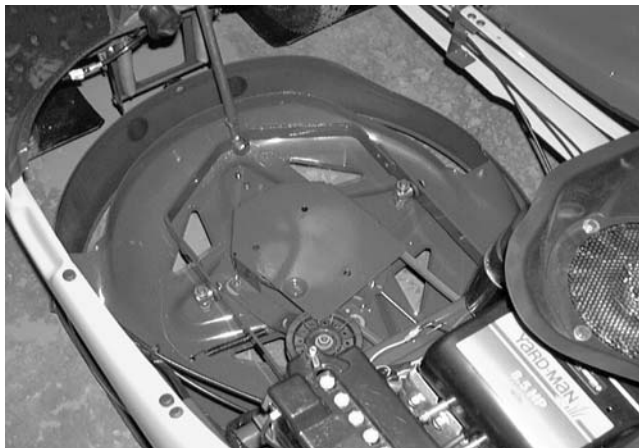
**➔ NOTE**

Make certain the same number of rotations are used for the left ball joint as the right ball joint.

**IMPORTANT:** Test the steering assembly for excessive tolerances. Make certain all the hardware is secure.

## REMOVAL AND INSTALLATION OF THE DECK BELT

1. Lower the deck to the lowest cutting position.
2. Raise the hood and remove the grass bag assembly and discharge chute. See Figure 8-28.



**Figure 8-28.**

3. Fully depress the deck pedal assembly and lock it down.
4. Remove both hex washer self tapping screws from the deck belt cover using a 1/2" socket.
5. Remove the top hex nut and lock washer from the idler bracket pivot screw using a 1/2" socket.

6. Remove the deck belt cover from the deck assembly. See Figure 8-29.

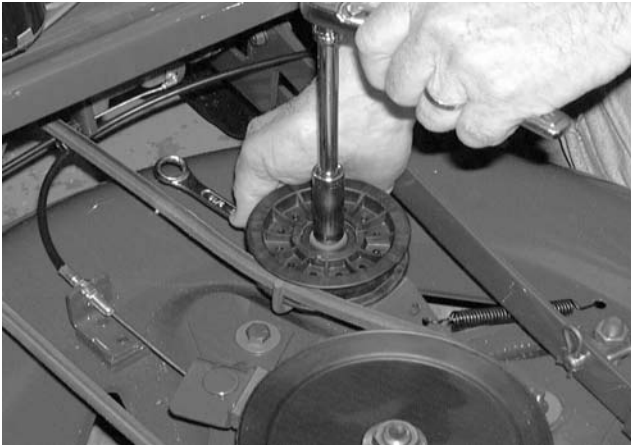


**Figure 8-29.**

**➔ NOTE**

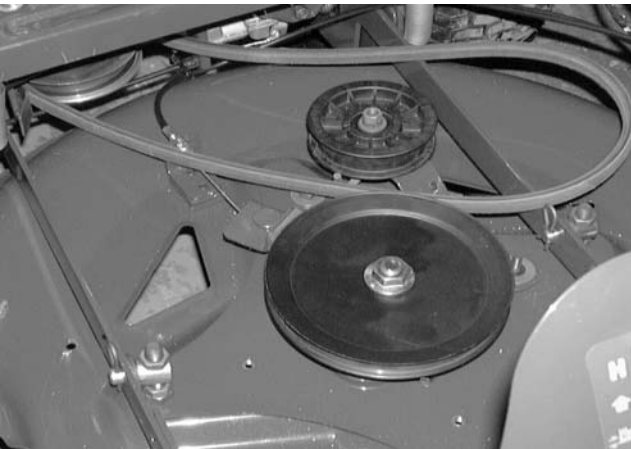
The deck belt must be engaged during deck belt cover installation. The belt keeper pin must not interfere with the deck belt.

7. Release the deck pedal assembly.
8. Loosen the hex nut that secures the flat idler pulley to the idler bracket using a 9/16" wrench and a 9/16" socket. See Figure 8-30.



**Figure 8-30.**

9. Raise the cutting deck to the highest cutting position.
10. Remove the deck belt from the flat idler pulley and the deck spindle pulley. See Figure 8-31.



**Figure 8-31.**

11. Remove the self tapping washer head hex screw that secures the left side of the half circle belt keeper to the frame using a 3/8" socket. See Figure 8-32.

**➡ NOTE**

The self tapping washer head hex screw is directly to the right of the front transmission support bracket.

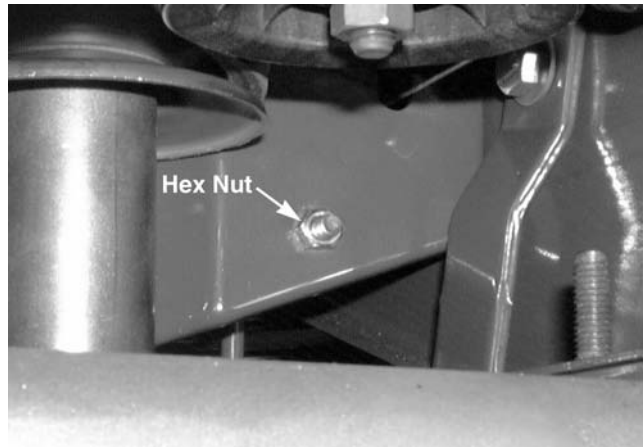


**Figure 8-32.**

12. Loosen the hex nut and lock washer that secures the right side of the half circle belt keeper to the frame using a 7/16" socket and a 6" extension. See Figure 8-33.

**➡ NOTE**

You must come in from the rear of the rider to access the hex nut and lock washer.



**Figure 8-33.**

13. Remove the deck belt from the rider.

**REINSTALL THE NEW DECK BELT IN THE REVERSE ORDER.**

# REMOVAL AND INSTALLATION OF THE MOWING DECK ASSEMBLY

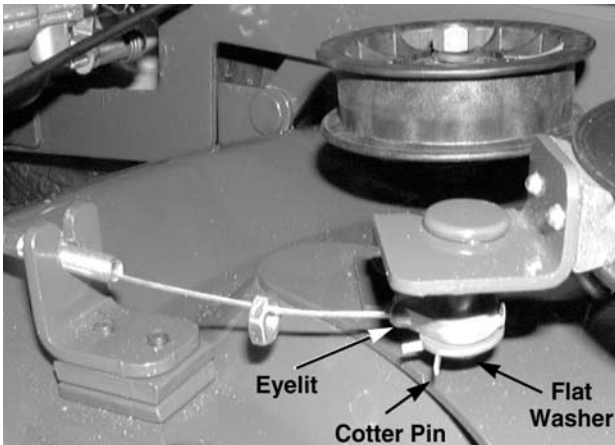
Prior to deck removal, perform deck belt removal.

1. Locate and loosen the hex jam nuts that secure the threaded end of the deck cable to the deck cable bracket using two 1/2" wrenches. See Figure 8-34.



**Figure 8-34.**

2. Remove the cotter pin and flat washer that secures the deck cable eyelit to the brake bracket pin.
3. Remove the deck cable eyelit from the brake bracket pin. See Figure 8-35.



**Figure 8-35.**

4. Remove both front deck extension springs from the front channel assembly. See Figure 8-36.

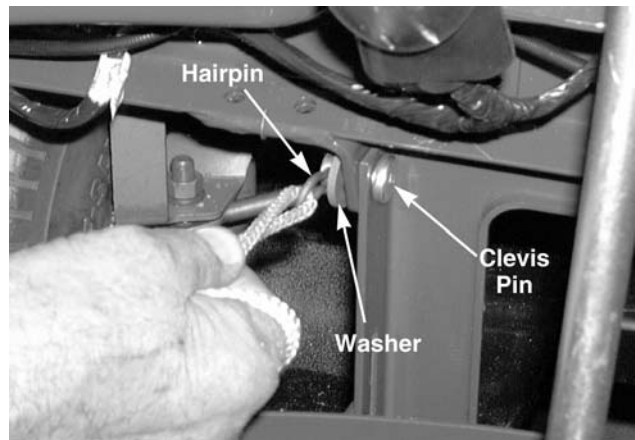
## ➔ NOTE

The use of a 2 foot piece of recoil rope can be used for spring removal.



**Figure 8-36.**

5. Remove both of the clevis pins, flat washers, and hairpin clips that secure the deck stabilizer bracket to the front channel assembly. See Figure 8-37.



**Figure 8-37.**

6. Remove both hairpin clips that secure the center deck ferrules to the lift link assembly. See Figure 8-38.

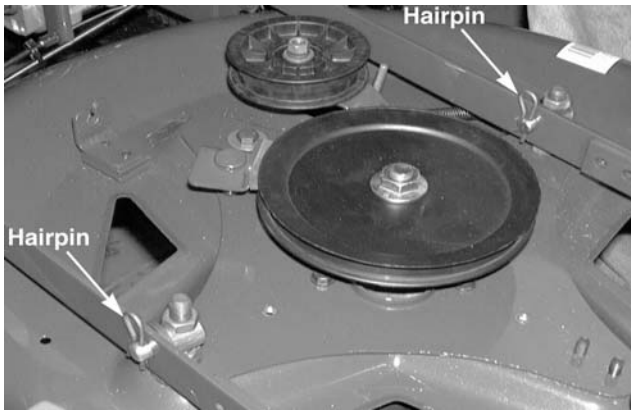


Figure 8-38.

**NOTE**

Both center deck ferrules are secured to the lift link assembly from the left. Also, there are two flat washers between the ferrules and the lift link assembly. See Figure 8-39.

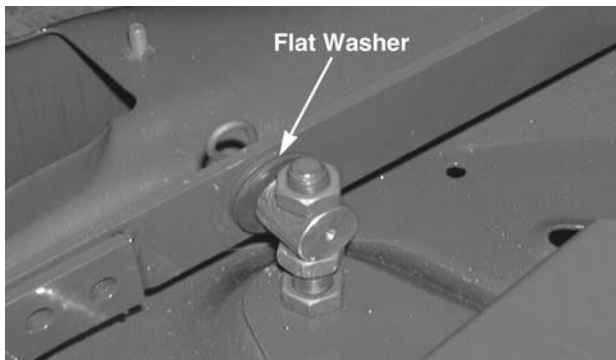


Figure 8-39.

## REMOVAL AND REPLACEMENT OF THE DRIVE BELTS

**NOTE**

The upper and lower drive belts are identical.

### LOWER DRIVE BELT:

1. From behind the rider, pull the spring loaded "V" idler towards the right frame rail and release the lower drive belt downward. See Figure 8-41.



Figure 8-41.

7. Remove both small hairpin clips and flat washers that secure the rear deck support pins to the lower "T" links. See Figure 8-40.

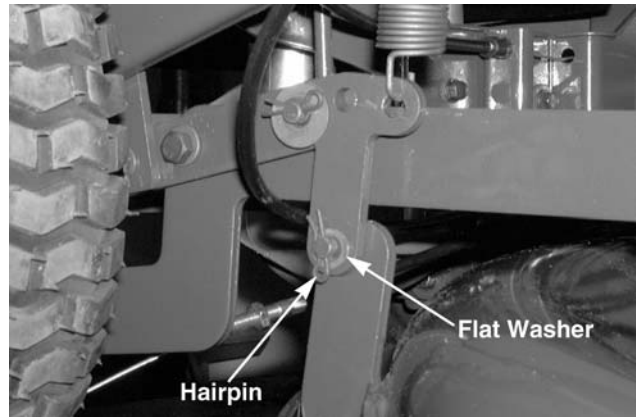
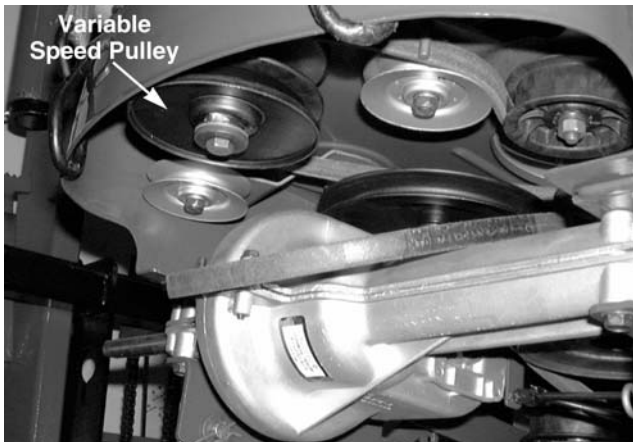


Figure 8-40.

8. Remove the mowing deck assembly.

**INSTALL THE MOWING DECK ASSEMBLY IN THE REVERSE ORDER ABOVE.**

3. Roll the lower drive belt down and off of the variable-speed pulley assembly. See Figure 8-42.



**Figure 8-42.**

4. Take hold of the lower drive belt and push it forward, up, and off of the transmission pulley. Pull it back towards the rear of the rider.

**INSTALL THE LOWER DRIVE BELT IN THE REVERSE ORDER ABOVE.**

**UPPER DRIVE BELT:**

**➡ NOTE**

Prior to removing the upper drive belt, it is necessary to remove the lower drive belt. See Figure 8-43.



**Figure 8-43.**

1. Remove the hex screw and lock washer that secures the engine pulley to the engine crankshaft using a 5/8" socket. See Figure 8-44.



**Figure 8-44.**

2. Slowly lower the engine pulley until the lower pulley is clear of the half circle belt keeper. See Figure 8-45.



**Figure 8-45.**

**➡ NOTE**

The drive belt must be moved to the right to keep it from catching the top of the transmission pulley.

3. Remove the deck belt from the lower engine pulley.
4. Push up on the upper drive belt and roll it off of the upper engine pulley.
5. Lower the engine pulley from the rider. See Figure 8-46.

**➡ NOTE**

Make certain that the square key is in the crankshaft during reassembly.



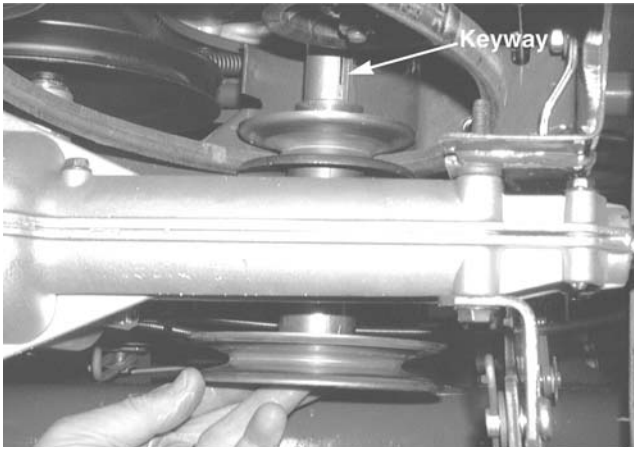


Figure 8-46.

6. Remove the upper drive belt from idler pulleys on the idler bracket and the crankshaft.
7. Roll the upper drive belt down and out of the variable-speed pulley assembly.

**INSTALL THE UPPER DRIVE BELT IN THE REVERSE ORDER ABOVE.**

## TRANSMISSION REMOVAL AND INSTALLATION



Prior to transmission removal, perform lower drive belt removal.

1. Raise the hood up and remove the grass bag assembly.
2. Lower the cutting height adjustment lever to the lowest position. See Figure 8-47.



Figure 8-47.

3. Raise the rear wheels off the ground. See Figure 8-48.

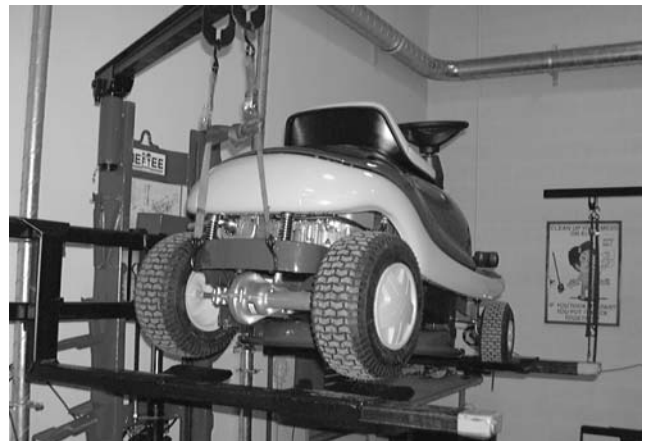


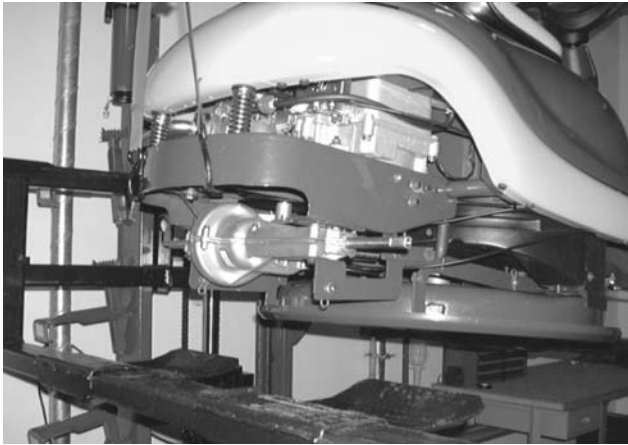
Figure 8-48.

4. Remove both hub caps from the rear wheel assemblies using a flat blade screw driver.
5. Remove the hex screws and bell washers that secure the rear wheel assemblies to the transmission axles using a 1/2" socket and a 6" extension.
6. Remove the rear wheel assemblies from the rider.



Make certain the rear axles are greased during reassembly. See Figure 8-49.



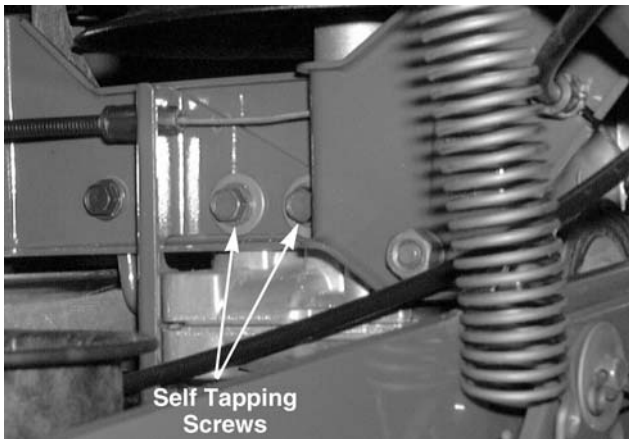


**Figure 8-49.**

7. Remove both hex washer head self tapping screws that secure the transmission support bracket to the transmission using a 3/8" socket. See Figure 8-50.

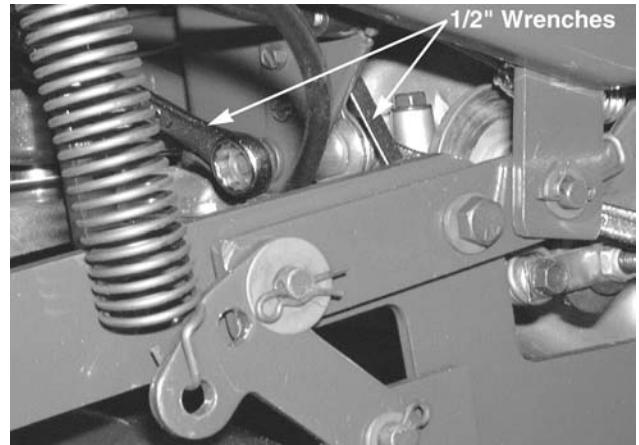
**NOTE**

Torque the hex washer head self tapping screws between 90 and 110 in-lbs. during installation.



**Figure 8-50.**

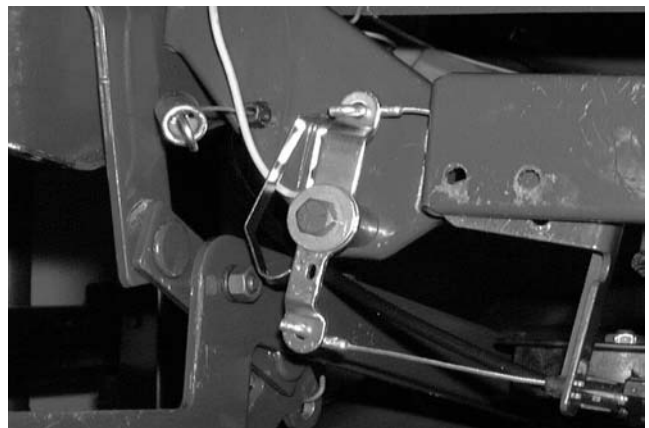
8. Remove the hex nut and lock washer from the shift lever cap screw using two 1/2" wrenches. See Figure 8-51.



**Figure 8-51.**

**NOTE**

During reinstallation remove the cotter pin securing the shift lever assembly to the transmission. Secure the shift lever assembly to the frame before reinstalling the transmission. See Figure 8-52.



**Figure 8-52.**

9. Loosen (DO NOT REMOVE) the locking hex nut that secures the brake actuation arm to the brake assembly using a 1/2" wrench. See Figure 8-53.

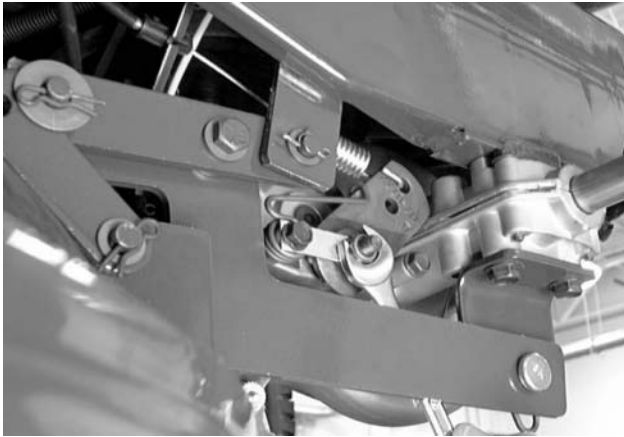


Figure 8-53.



Perform the BRAKE ADJUSTMENT section during reassembly.

10. Pull the brake actuation arm forward and remove the brake cable spring from the brake actuation arm. See Figure 8-54.

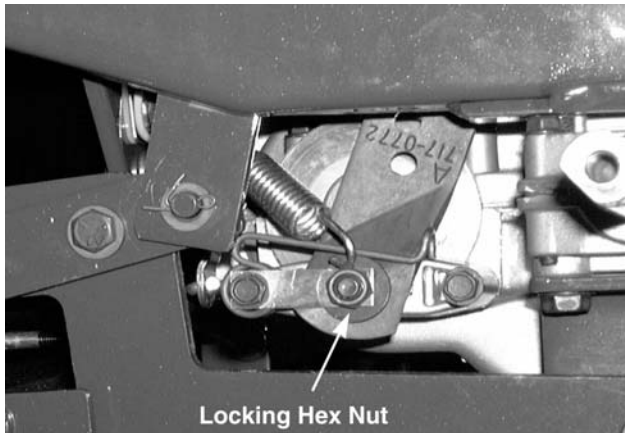


Figure 8-54.

11. Remove all four self tapping hex screws that secure the transmission to the frame using a 1/2" socket.
12. Slide the transmission slowly to the rear and remove the shift cable "Z" fittings from the shift lever. See Figure 8-55.

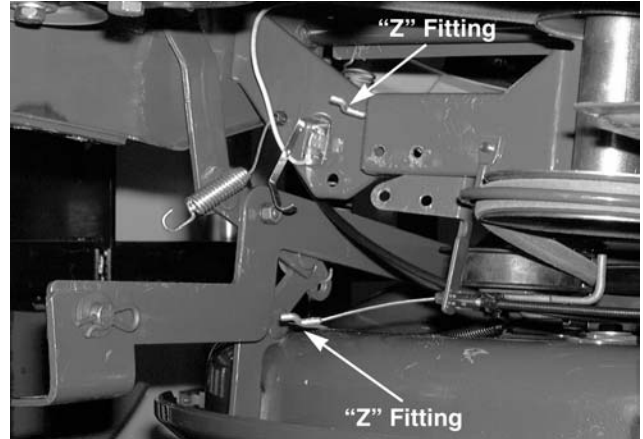


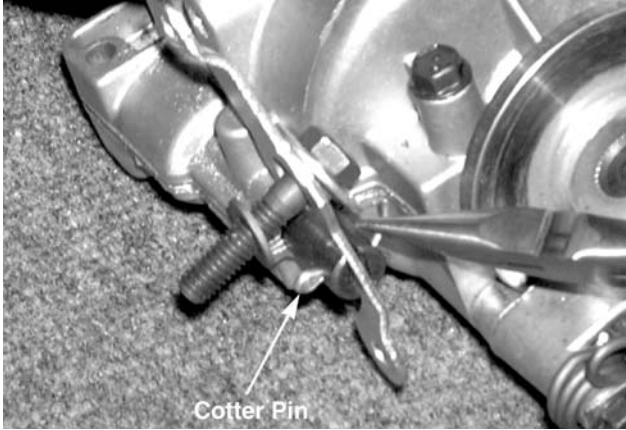
Figure 8-55.

- 13). Remove the transmission from the rider.

**INSTALL THE TRANSMISSION IN THE REVERSE ORDER ABOVE.** Set the transmission on a work bench with the transmission pulley facing up.

# TRANSMISSION DISASSEMBLY

1. Set the transmission on a work bench with the transmission pulley facing up.
2. Remove the cotter pin securing the shift lever to the shift fork assembly using needle nose pliers. See Figure 8-56.



**Figure 8-56.**

3. Place a "C" clamp over the transmission pulley and tighten it down on the flat area of the pulley.
4. Rotate the "C" clamp until it rests up against the upper transmission housing.
5. Loosen the hex jam nut securing the transmission pulley to the input shaft using a 7/8" socket.
6. Remove the hex jam nut, belleville washer, and transmission pulley from the input shaft. See Figure 8-57.



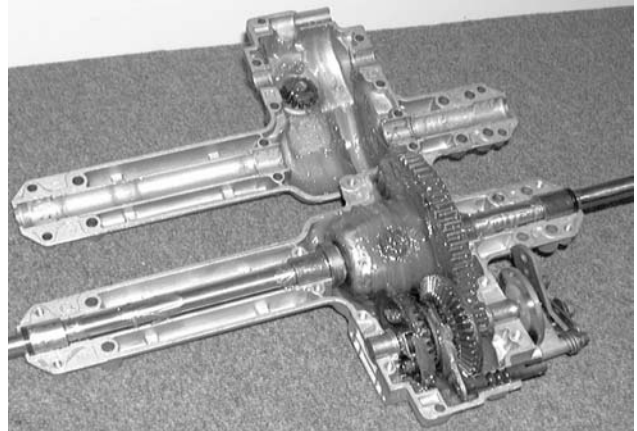
**Figure 8-57.**

7. Loosen and remove all of the hex washer head self tapping screws that secure the upper and lower transmission housings together using a 3/8" socket.

## ➡ NOTE

The two longest hex washer head self tapping screws secure the brake area.

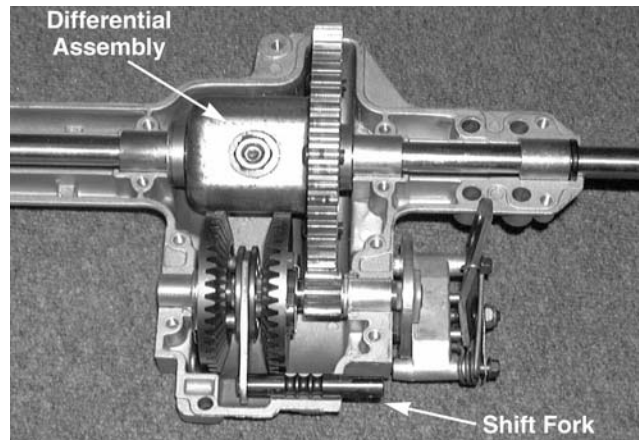
8. Remove the upper transmission housing. See Figure 8-58.



**Figure 8-58.**

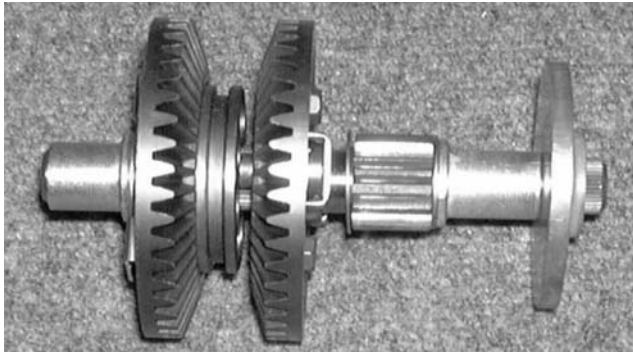
## ➡ NOTE

The transmission assembly has been cleaned out for clarity. See Figure 8-59.



**Figure 8-59.**

9. Remove the differential assembly. See Figure 8-60.
10. Remove the shift fork, detent ball, and spring. See Figure 8-60.
11. Remove the upper drive shaft assembly. See Figure 8-60.



**Figure 8-60.**

12. Disassemble and inspect all components of the upper drive shaft assembly. See Figure 8-61



**Figure 8-61.**

13. Place the upper transmission housing flat on the bench with the input shaft facing up.
14. Remove the wire ring, "E"-clip, and flat washer from the input shaft.

**NOTE**

There may be an additional shim washer on the input shaft to alleviate excessive tolerances.

15. Lift the upper transmission housing and remove the input shaft.
16. Remove the thrust washer from the input shaft.
17. The input pinion can be separated from the input shaft by removing the retaining ring. See Figure 8-62.



**Figure 8-62.**

18. Clean all components of the transmission assembly.

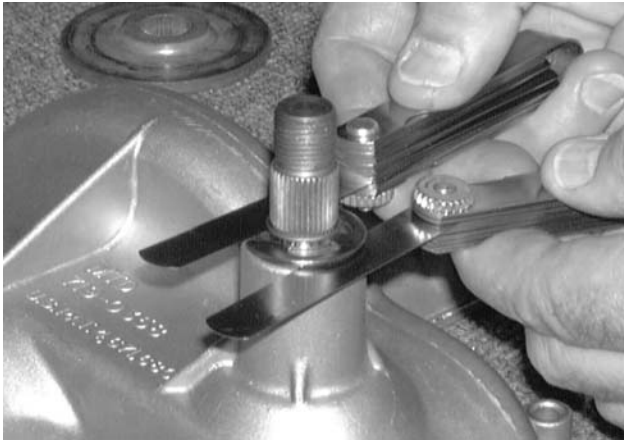
## TRANSMISSION REASSEMBLY

1. Inspect the needle bearings in the upper transmission housing.
2. Inspect the input shaft and pinion.
3. Apply never seez to the input shaft.
4. Slide the thrust washer over the input shaft.
5. Slide the input shaft up through the needle bearings in the upper transmission housing.
6. Slide the flat washer over the input shaft.

**NOTE**

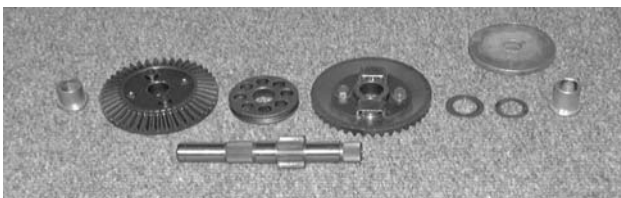
The tolerance will be between .006" and .015". If not, place shim washers between the flat washer and the upper transmission housing.

7. Install the "E" ring and wire ring on to the input shaft.
8. Make certain the input shaft does not have excessive tolerance by placing two feeler gauges between the flat washer and the upper transmission housing. See Figure 8-63.



**Figure 8-63.**

9. Rotate the upper transmission housing 180 degrees and set it on the bench with the input pinion facing up.
10. Inspect all components of the upper drive shaft assembly.
11. Apply never seez to the drive shaft.
12. Grasp the short end of the drive shaft with your right hand.
13. Slide the thrust washer, bevel gear with large inner diameter hole, clutch collar, bevel gear with small inner diameter hole, flat washer, and short flange bearing over the long end of the drive shaft. See Figure 8-64.
14. Holding the assembly in your left hand, slide the flat washer, long flange bearing, and brake disc over the short end of the drive shaft.



**Figure 8-64.**

**➔ NOTE**

There may be additional shim washers on the shaft assembly to alleviate excessive tolerances.

15. Set the upper drive shaft assembly into the upper transmission housing. See Figure 8-65.

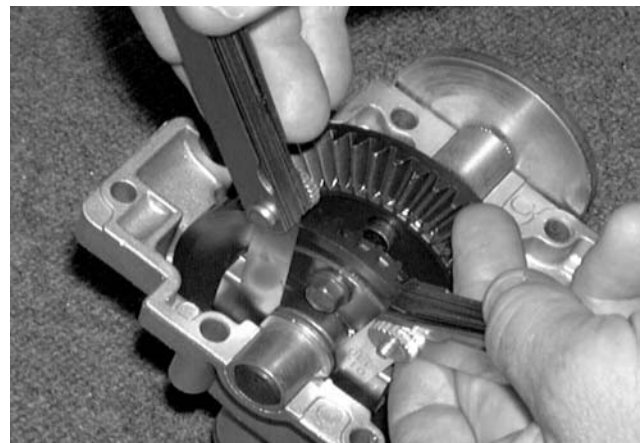


**Figure 8-65.**

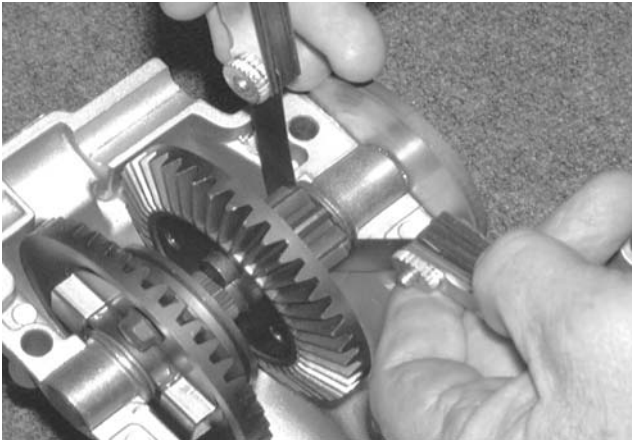
16. Make certain both bushings are seated correctly in the upper housing and the bevel gears have meshed properly with the input pinion.
17. Make certain the upper drive shaft assembly is within tolerance by placing two feeler gauges between the flat washer and the bushing behind each bevel gear. See Figures 8-66 and 8-67.

**➔ NOTE**

The tolerance will be between .006" and .015" on both sides. If not, place a shim washer between the flat washer and the bushing on the side that is out of tolerance.



**Figure 8-66.**



**Figure 8-67.**

18. Place a dab of grease on the puck plate and brake puck before installing it into the brake yoke assembly.
19. Install the puck plate and brake puck into the brake yoke assembly.
20. Secure the brake yoke assembly to the lower transmission housing using a 3/8" socket.

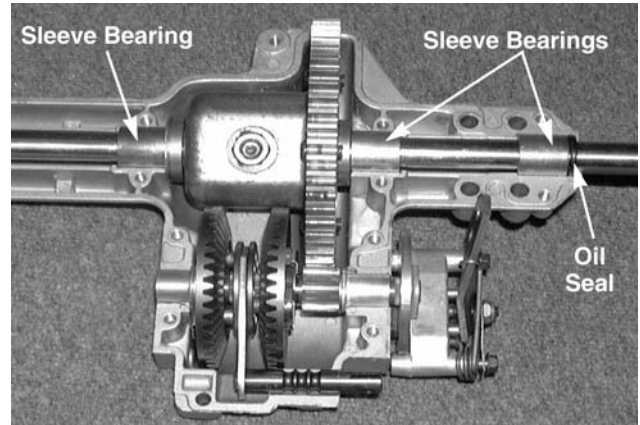
**➔ NOTE**

Torque both hex washer head self tapping screws between 90 and 110 in.-lbs.

21. Set the upper drive shaft assembly into the lower transmission housing.
22. Make certain both bushings are seated correctly in the lower housing.
23. Inspect the oil seals and sleeve bearings on the differential assembly.
24. Grease both axle shafts of the differential assembly.
25. Place the differential assembly into the lower transmission housing. See Figure 8-68.

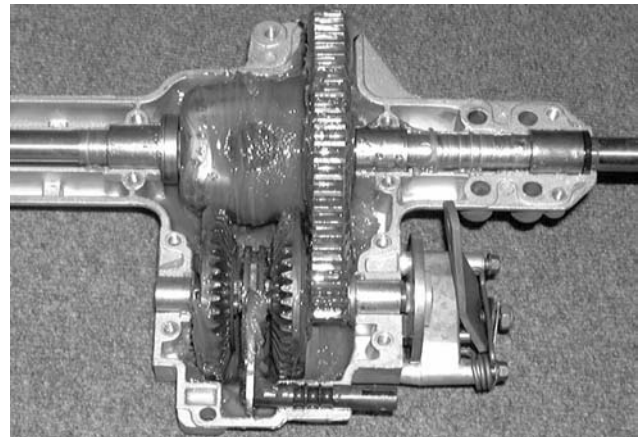
**➔ NOTE**

Make certain the oil seals and sleeve bearings are seated properly in the lower housing.



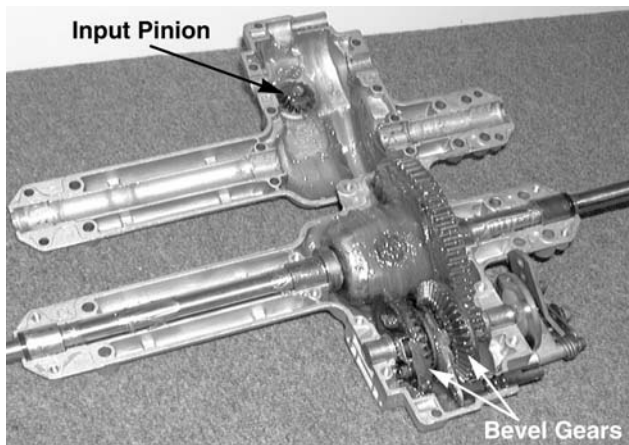
**Figure 8-68.**

26. Fully grease the transmission. See Figure 8-69.



**Figure 8-69.**

27. Place the detent spring and ball into the lower transmission housing.
28. Never seize the shift fork assembly and install it into the shift collar.
29. Place the upper transmission housing over the lower housing and rotate the input shaft, making certain the bevel gears mesh correctly with the input pinion. See Figure 8-70.



**Figure 8-70.**

30. Install and hand tighten all of the hex washer head self tapping screws that secure the upper and lower transmission housings together.

**NOTE**

Make certain the two longest self tapping screws are securing the brake area.

## ELECTRICAL (START CIRCUIT)

**IMPORTANT:** This section is used for electrical training. Even though some of the subsections are called out, this section is meant to be performed inclusively. If you are working on a specific section, make certain all devices are in the proper modes (switches, relays, and etc...)

**NOTE**

A multimeter is a must for this section. If any of the following tests do not match, repair that portion of the system.

**GENERAL CONTINUITY:**

1. Turn the ignition key to the "OFF" position.
2. Place the multimeter in the OHM'S mode until instructed to change modes. See Figure 8-71.

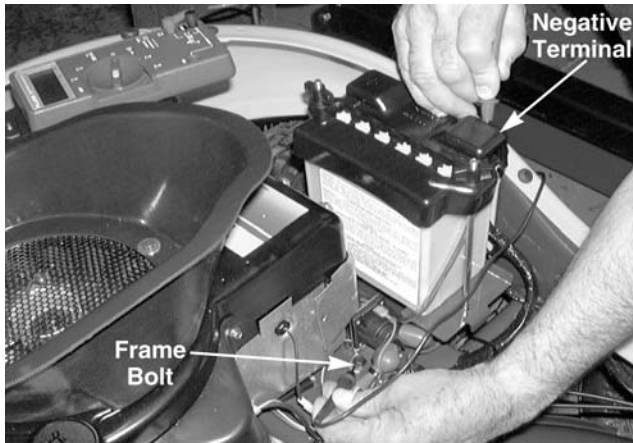


**Figure 8-71.**

31. Torque all hex washer head self tapping screws between 90 and 110 in.-lbs.
32. Install the transmission pulley, belleville washer, and hex jam nut onto the input shaft.
33. Place a "C" clamp over the transmission pulley and tighten it down on the flat area of the pulley.
34. Rotate the "C" clamp until it rests up against the upper transmission housing.
35. Torque the hex jam nut on the input shaft between 300-400 in.-lbs.
36. Secure the shift lever to the shift fork assembly using the cotter pin removed in disassembly.
37. Test operations.

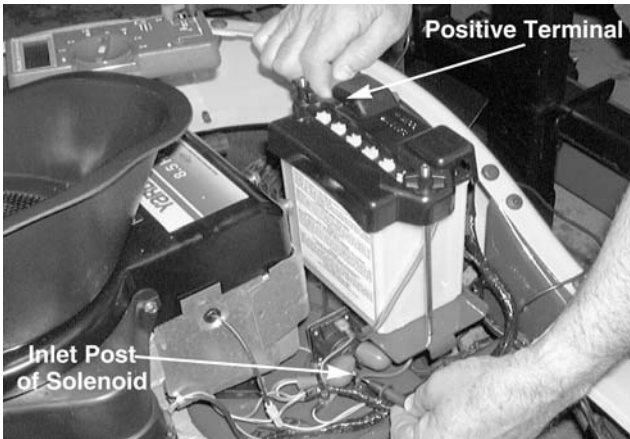
3. Place one probe on the negative battery terminal. Place the second probe on the frame bolt. -There will be **CONTINUITY**. See Figure 8-72.





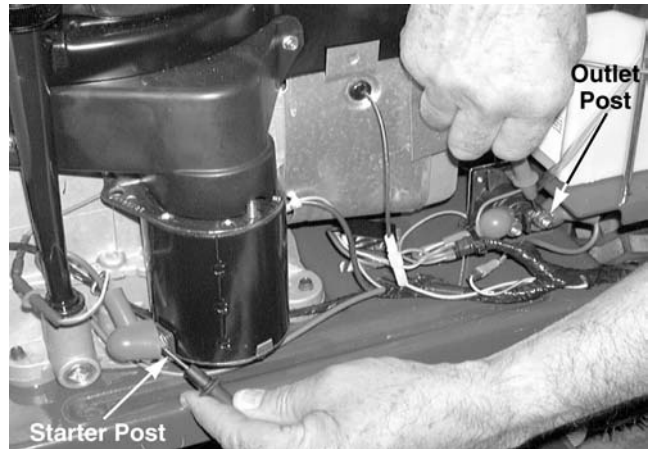
**Figure 8-72.**

4. Place one probe on the positive battery terminal. Place the second probe on the inlet post of the solenoid.  
–There will be **CONTINUITY**. See Figure 8-73.



**Figure 8-73.**

5. Place one probe on the negative battery terminal. Place the second probe on the engine block.  
–There will be **CONTINUITY**.
6. Place one probe on the outlet post of the solenoid. Place the second probe on the starter post.  
–There will be **CONTINUITY**. See Figure 8-74.

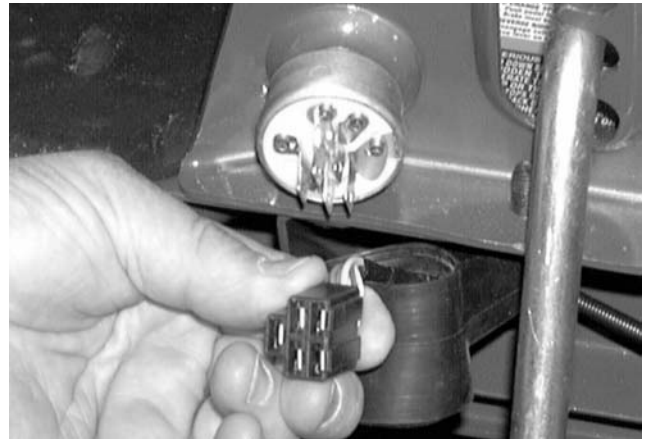


**Figure 8-74.**

7. Place one probe on the negative battery terminal. Place the second probe on the solenoid base.  
–There will be **CONTINUITY**.

**IGNITION SWITCH:**

8. Locate the ignition switch and remove the wiring harness connector. See Figure 8-75.

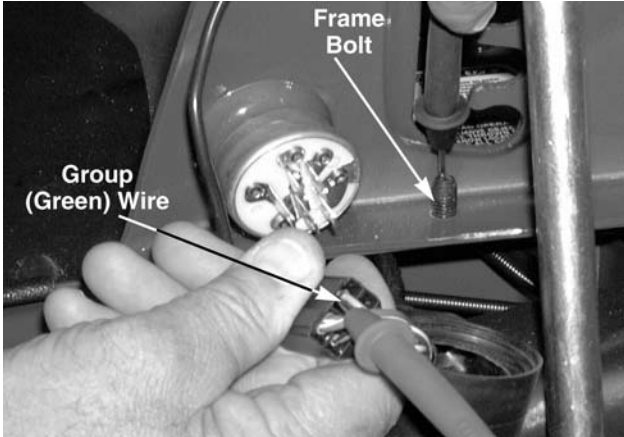


**Figure 8-75.**

9. Locate and identify all ignition switch terminals. **L**–Alternator, **S**–Start, **M**–Magnet, **G**–Ground, **B**–Battery.
10. Locate and identify all wires coming into the wiring harness connector at the ignition switch. **Green**–Ground, **Red**–Battery, **Yellow**–Magnet, **Red/White**–Alternator, **Orange/Black**–Start.



11. Place one probe on any frame bolt. Place the second probe on the ground (green) wire of the ignition switch connector.  
–There will be **CONTINUITY**. See Figure 8-76.



**Figure 8-76.**

**FUSE:**

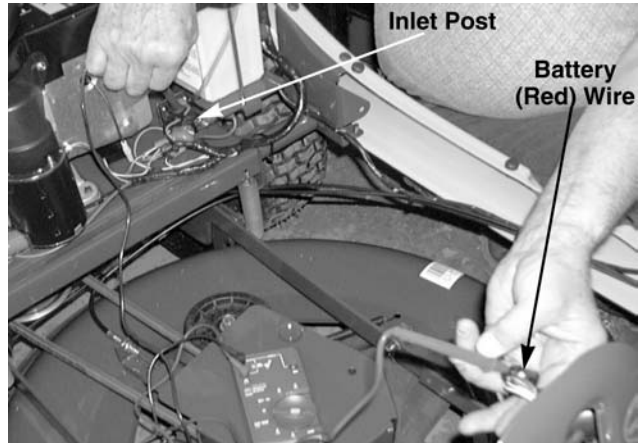
12. Locate and remove the fuse from the fuse connector. See Figure 8-77.



**Figure 8-77.**

13. Place one probe on one male terminal of the fuse. Place the second probe on the second male terminal of the fuse.  
–There will be **CONTINUITY**.
14. Place the fuse back into the fuse holder.
15. Place one probe on the inlet post of the solenoid. Place the second probe on the battery (red) wire of the ignition switch connector.

–There will be **CONTINUITY**. See Figure 8-78.



**Figure 8-78.**

16. Place the multimeter in the **D.C. VOLTS** mode.
17. Place the red probe on the positive battery (red) wire and the black probe on the ground (green) wire of the ignition switch connector.  
–There will be **12 VOLTS**. See Figure 8-79.



**Figure 8-79.**

18. Place the multimeter in the **OHM's** mode.
19. Place one probe on the “**B**” terminal and the second probe on the “**S**” terminal of the ignition switch.  
–There will be **NO CONTINUITY**.
20. Turn the ignition key to the “**START**” (spring loaded) position.  
–There will be **CONTINUITY**.

**NOTE**

Turn the ignition key back to the “OFF” position after completion.

21. **DO NOT** reconnect the wiring harness to the ignition switch.

**BRAKE SWITCH:**

22. Locate the brake switch. See Figure 8-80.



Figure 8-80.

23. Identify the **NC** (normally closed) terminals of the brake switch.
24. Place one probe on one **NC** (yellow) terminal and the second probe on the second **NC** (yellow) terminal of the brake switch.  
–There will be **CONTINUITY**. See Figure 8-81.
25. Depress the plunger on the brake switch.  
–There will be **NO CONTINUITY**. See Figure 8-81.

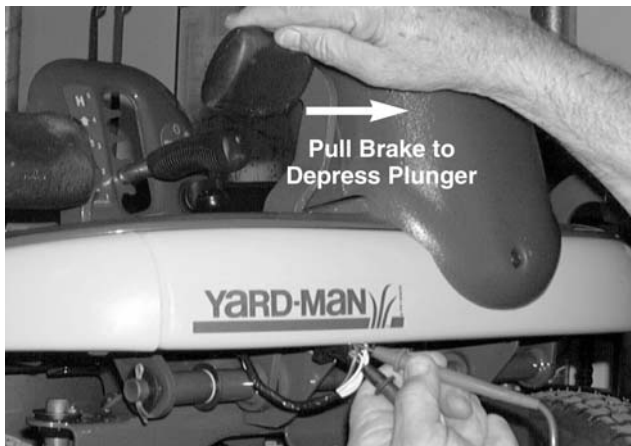


Figure 8-81.

26. Release the plunger and place the probes on the **NO** (normally open– orange) terminals.  
–There will be **NO CONTINUITY**.
27. Depress the plunger on the brake switch.  
–There will be **CONTINUITY**.

**PTO SWITCH:**

28. Locate the PTO switch.
29. Identify the **NC** (normally closed) terminals of the PTO switch. See Figure 8-82.

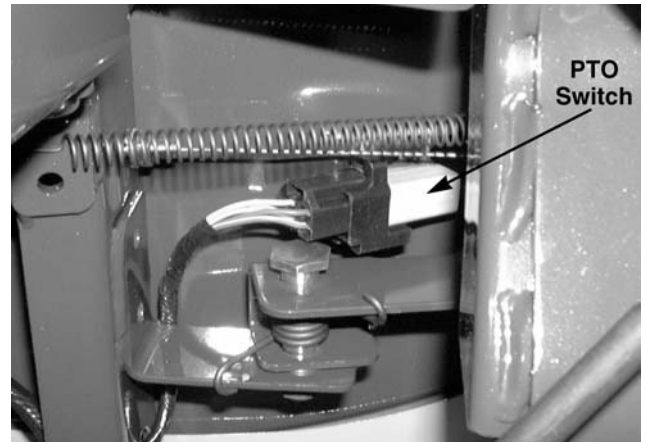


Figure 8-82.

30. Place one probe on one **NC** (yellow) terminal and the second probe on the second **NC** (yellow) terminal of the PTO switch.  
–There will be **CONTINUITY**.
31. Depress the plunger on the PTO switch.  
–There will be **NO CONTINUITY**.
32. Release the plunger and place the probes on the **NO** (normally open– orange) terminals.  
–There will be **NO CONTINUITY**.
33. Depress the plunger on the PTO switch.  
–There will be **CONTINUITY**.

**SOLENOID:**

34. Locate and remove the orange– female connector wire that is connected to the male actuation terminal of the solenoid.
35. Lock the parking brake down.

36. Make certain the deck engagement pedal is fully disengaged (UP) and depressing the plunger on the PTO switch all the way.
37. Place one probe of the multimeter on the orange/black wire of the wiring harness ignition connector. Place the second probe on the female connector of the orange wire that was disconnected from the male actuation terminal of the solenoid.  
–There will be **CONTINUITY**.
38. Place one probe on the base (steel portion) and the second probe on the male actuation terminal of the solenoid.  
–There will be approximately 5 OHM'S at room temperature.

**➔ NOTE**

The OHM's reading will rise or fall slightly depending on the current temperature.

39. Reconnect the orange wire– female connector to the male actuation terminal of the solenoid.
40. Reconnect the wiring harness ignition connector to the ignition switch.
41. Disconnect the thick red wire (solenoid to starter) from the outlet post of the solenoid using a 7/16" wrench.
42. Place one probe on the inlet post and one probe on the outlet post of the solenoid.  
–There will be **NO CONTINUITY**.
43. Turn the ignition key to the “**START**” (spring loaded) position.  
–There will be **CONTINUITY**.

**➔ NOTE**

Turn the ignition key to the “**OFF**” position after completion.

## ELECTRICAL (OFF/SAFETY CIRCUIT)

44. Reconnect the thick red wire (solenoid to starter) to the outlet post of the solenoid using a 7/16" wrench.
45. Make certain all connections are secure and test the starting circuit.

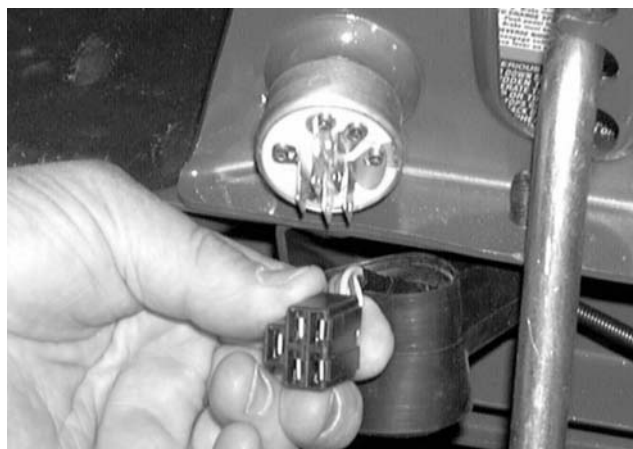
**IMPORTANT:** This section is used for electrical training. Even though some of the subsections are called out, this section is meant to be performed inclusively. If you are working on a specific section, make certain all devices are in the proper modes (switches, relays, and etc...)

**➔ NOTE**

A multimeter is a must for this section. If any of the following tests do not match, repair that portion of the system.

### IGNITION SWITCH:

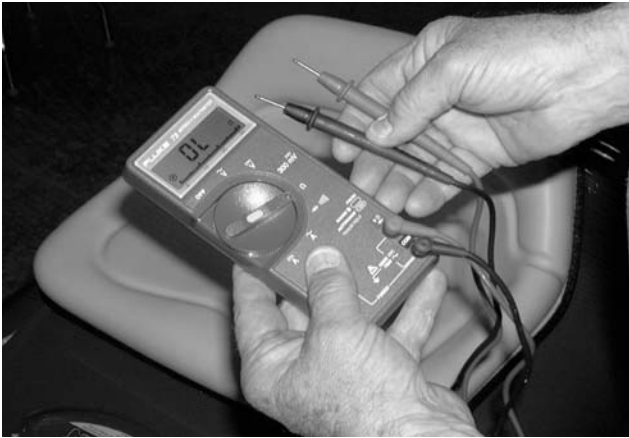
1. Turn the ignition key to the “**OFF**” position.
2. Locate the ignition switch and remove the wiring harness connector. See Figure 8-83.



**Figure 8-83.**

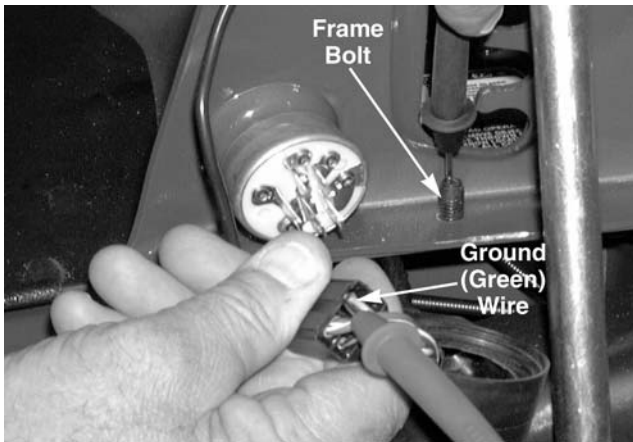
3. Locate and identify all ignition switch terminals. **L**—Alternator, **S**—Start, **M**—Magneto, **G**—Ground, **B**—Battery.
4. Locate and identify all wires coming into the wiring harness connector at the ignition switch. **Green**—Ground, **Red**—Battery, **Yellow**—Magneto, **Red/White**—Alternator, **Orange/Black**—Start.

- Place the multimeter in the OHM's mode until instructed to change modes. See Figure 8-84.



**Figure 8-84.**

- Place one probe on any frame bolt. Place the second probe on the ground (green) wire of the ignition switch connector. –There will be **CONTINUITY**. See Figure 8-85.



**Figure 8-85.**

- Place one probe on the “G” terminal and one probe on the “M” terminal of the ignition switch. –There will be **CONTINUITY**.

#### **MAGNETO:**

- Locate the magneto (yellow) wire coming off of the engine.
- Disconnect the magneto (yellow) wire from the magneto harness wire at the connector.
- Place one probe of the multimeter into the wiring harness magneto (yellow) wire connector. Place the second probe on the magneto (yellow) wire of the ignition switch connector. –There will be **CONTINUITY**. See Figure 8-86.



**Figure 8-86.**

- Reconnect the magneto (yellow) wire to the magneto harness wire.
- DO NOT** reconnect the wiring harness connector to the ignition switch.

#### **PTO SWITCH:**

- Locate the PTO switch and remove the wiring harness connector. See Figure 8-87.



**Figure 8-87.**

- Identify the **NC** (normally closed) terminals of the PTO switch.
- Place one probe on one **NC** terminal and the second probe on the second **NC** terminal of the PTO switch. –There will be **CONTINUITY**.
- Depress the plunger on the PTO switch. –There will be **NO CONTINUITY**.
- Release the plunger and place the probes on the **NO** (normally open) terminals.

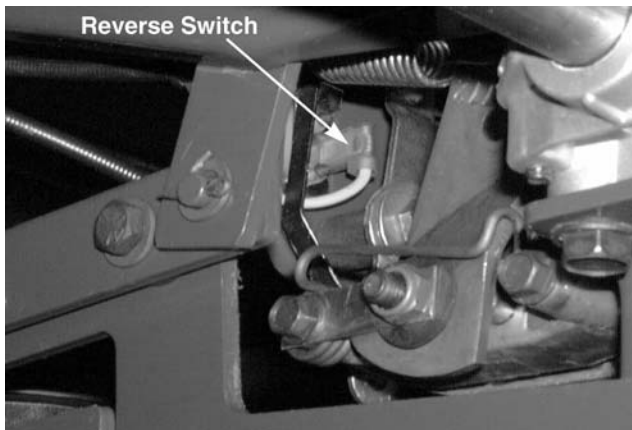
–There will be **NO CONTINUITY**.

18. Depress the plunger on the PTO switch.  
–There will be **CONTINUITY**.

19. Reconnect the wiring harness connector to the PTO switch.

#### REVERSE SWITCH:

20. Locate the reverse switch and disconnect the yellow/black wire and connector. See Figure 8-88.

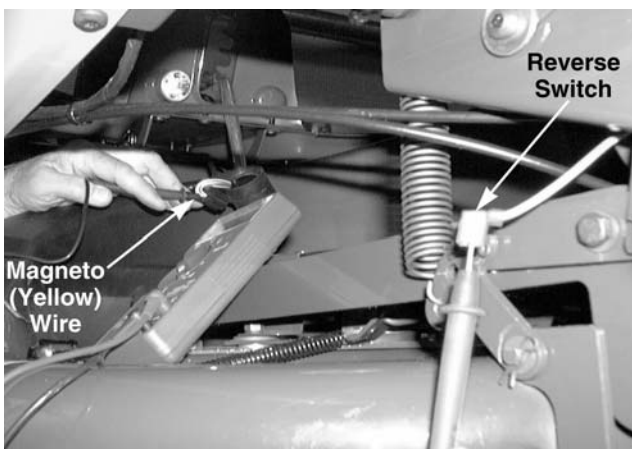


**Figure 8-88.**

21. Make certain the unit is off. Engage and lock down the cutting deck engagement pedal.

22. Place one probe of the multimeter into the yellow/black wire connector off of the reverse switch. Place the second probe on the magneto (yellow) wire of the ignition switch connector.

–There will be **CONTINUITY**. See Figure 8-89.



**Figure 8-89.**

#### RELAY CONNECTOR–(PTO switch):

23. Locate the relay connector with the yellow/black wire running into it. See Figure 8-89.

24. Place one probe on the yellow/black wire going into the relay connector. Place the second probe on the magneto (yellow) wire of the ignition switch connector.  
–There will be **CONTINUITY**.

#### BRAKE SWITCH:

25. Locate the brake switch and remove the wiring harness connector. See Figure 8-90.



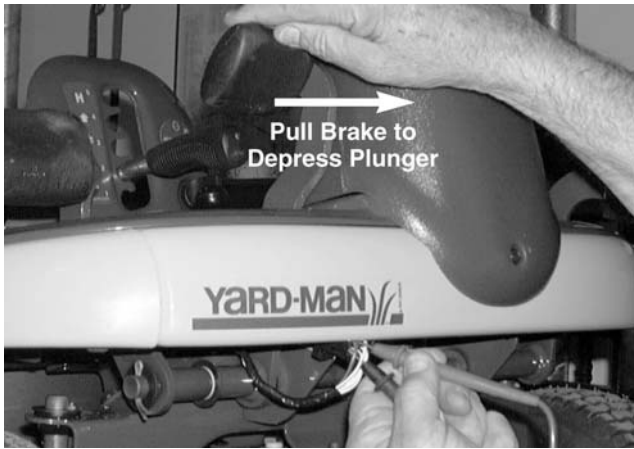
**Figure 8-90.**

26. Identify the **NC** (normally closed) terminals of the brake switch.

27. Place one probe on one **NC** terminal. Place the second probe on the second **NC** terminal of the brake switch.

–There will be **CONTINUITY**.

28. Depress the plunger on the brake switch.  
–There will be **NO CONTINUITY**. See Figure 8-91.

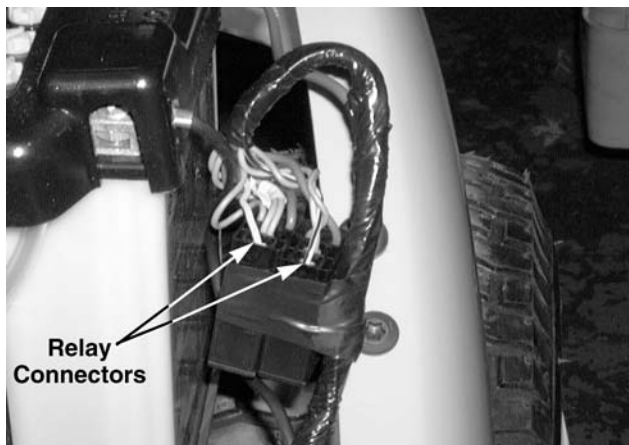


**Figure 8-91.**

29. Release the plunger and place the probes on the NO (normally open) terminals.  
–There will be **NO CONTINUITY**.
30. Depress the plunger on the brake switch.  
–There will be **CONTINUITY**.
31. Reconnect the wiring harness connector on the he brake switch.
32. Make certain the brake pedal is fully released (up).

**RELAY CONNECTOR– (brake switch):**

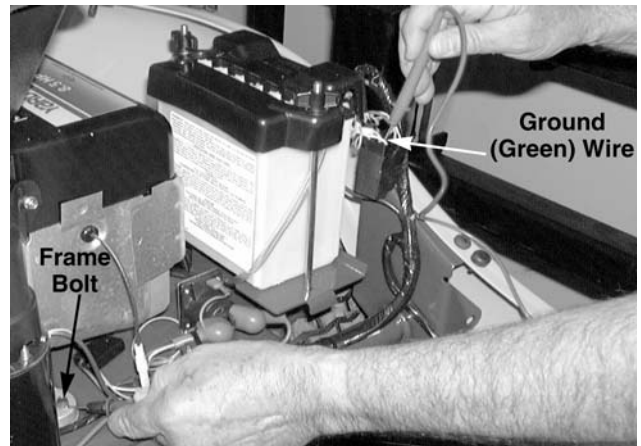
33. Locate the relay connector with the yellow/white wire running into it. See Figure 8-92.



**Figure 8-92.**

34. Place one probe on the yellow/white wire going into the relay connector. Place the second probe on the magneto (yellow) wire of the ignition switch connector.  
–There will be **CONTINUITY**.

35. Place one probe on any frame bolt. Touch the second probe to the ground (green) wires coming into both relays (all four positions).  
–There will be **CONTINUITY**. See Figure 8-93.

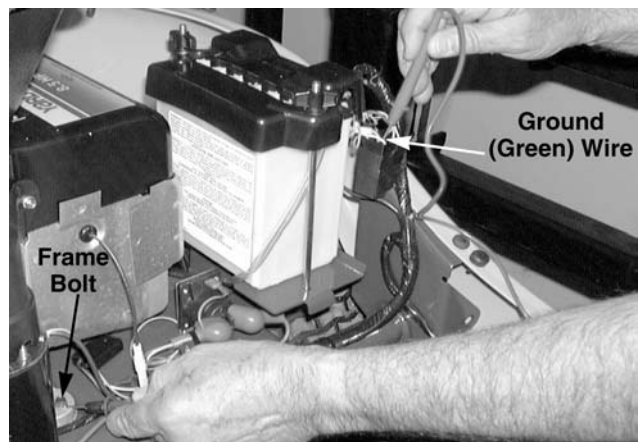


**Figure 8-93.**

36. Turn the ignition key to the “ON” position.
37. Place one probe on the “B” terminal and one probe on the “L” terminal of the ignition switch.  
–There will be **CONTINUITY**.

**SEAT SWITCH:**

38. Locate the seat switch and remove both female harness connectors. See Figure 8-94.



**Figure 8-94.**

39. Place one probe on one male terminal and the second probe on the second male terminal of the seat switch.  
–There will be **CONTINUITY**.
40. Push the seat cushion in and activate the seat switch.  
–There will be **NO CONTINUITY**.

41. Reconnect both female harness connectors to the seat switch.
42. Locate the red wires coming into both relay connectors.
43. Place one probe on the alternator (red/white) wire of the ignition switch connector. Touch the second probe on the red wires coming into both relay connectors.  
–There will be **CONTINUITY**.

#### ALTERNATOR:

44. Locate and disconnect the alternator (red) wire from the harness (red/white) wire connector at the engine.
45. Place one probe in the round (red/white) alternator connector on the harness. Place the second probe on the alternator (red/white) wire of the ignition switch connector.  
–There will be **CONTINUITY**.
46. Reconnect the alternator (red) wire to the harness (red/white) wire connector at the engine.
47. Reconnect the ignition switch wiring harness connector to the ignition switch.

#### RELAYS:

48. Remove both relays from the wiring harness relay connectors.
49. Locate and identify all terminals on the relays using the wiring diagram on the side of the relays.
50. Place one probe on terminal 3. Place the second probe on terminal 4.  
–There will be **CONTINUITY**.
51. Place one probe on terminal 3. Place the second probe on terminal 5.  
–There will be **NO CONTINUITY**.
52. Place one probe on terminal 1. Place the second probe on terminal 2.  
–There will be app. **82 OHM's** at room temperature.

#### **NOTE**

The OHM's reading will rise or fall depending on the temperature of the relay.

53. Place a red jumper wire on the positive terminal of a battery. Place a black jumper wire on the negative terminal of a battery.
54. Attach the red jumper wire to terminal 2 of the relay. Attach the black jumper wire to terminal 1 of the relay.  
–There will be one **CLICK**.
55. Leave the relay attached to the battery. Place one probe on terminal 3. Place the second probe on terminal 4.  
–There will be **NO CONTINUITY**.
56. Leave the relay attached to the battery. Place one probe on terminal 3. Place the second probe on terminal 5.  
–There will be **CONTINUITY**.
57. Disconnect the relay from the battery. Repeat steps 50 through 56 for the second relay.
58. Place the multimeter into the **D.C. VOLTS** mode.
59. Locate and identify the red and green wires that come into the relay connectors at relay terminal positions **1** and **2**.
60. Make certain the ignition key is **“ON”**.
61. Place the red probe on the red wire and the black probe on the green wire of the relay connector.  
–There will be **12 VOLTS**.

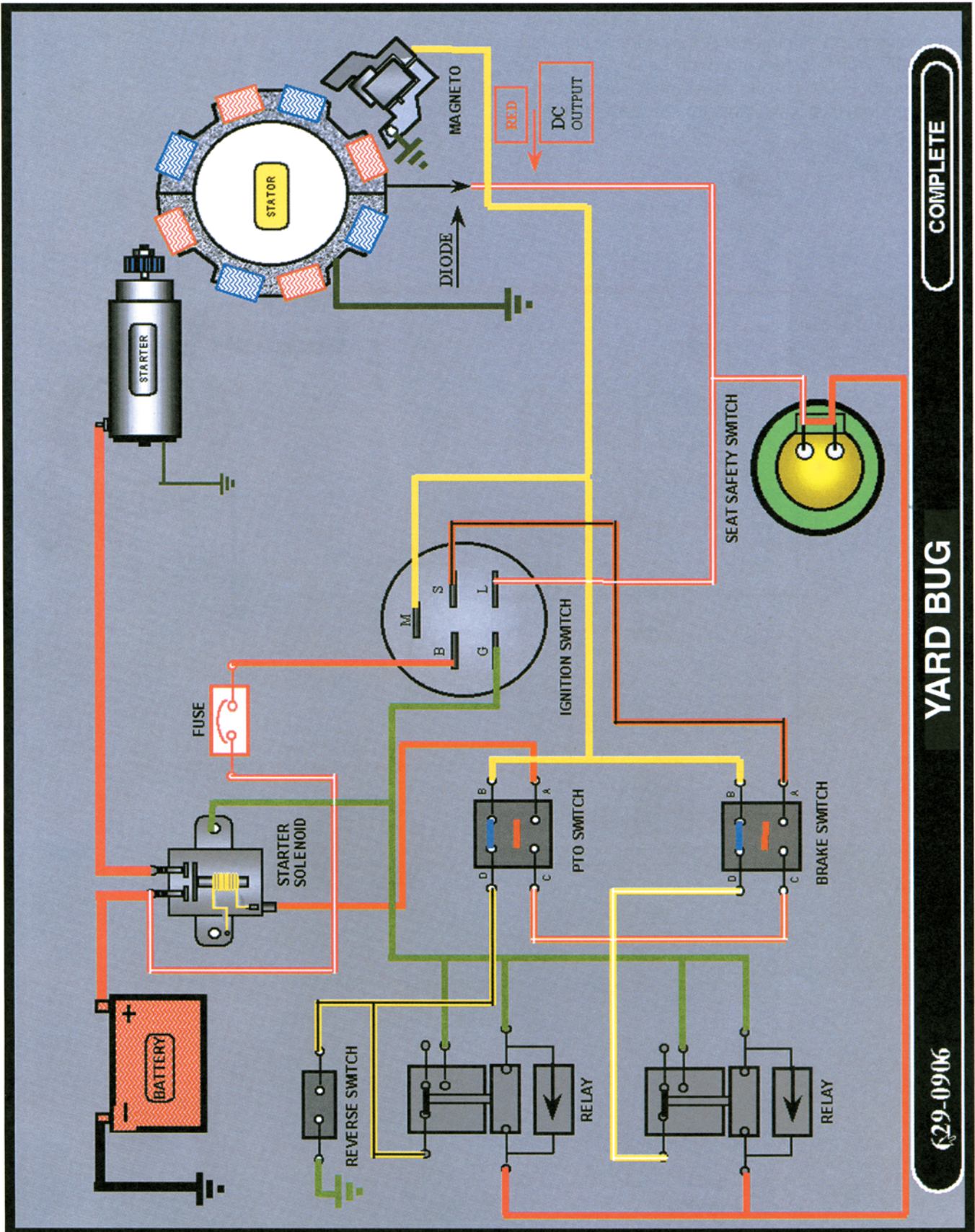
#### **NOTE**

Repeat this step for the second relay connector.

62. Turn the ignition key to the **“OFF”** position.
63. Reconnect the relays to the wiring harness relay connectors.
64. Make certain all wiring harness connections are secure and test the **OFF/SAFETY CIRCUIT**.



# Electrical Drawing



COMPLETE

YARD BUG

29-0906



# YARDBUG

## New wiring harness 629-0945

Relays have been eliminated. A new seat switch, four prong, N/C, running ground has been used since November 15, 2000. The old seat switch, N/O, 2 prong, running ground, is still available for service. See Figure 8-83.

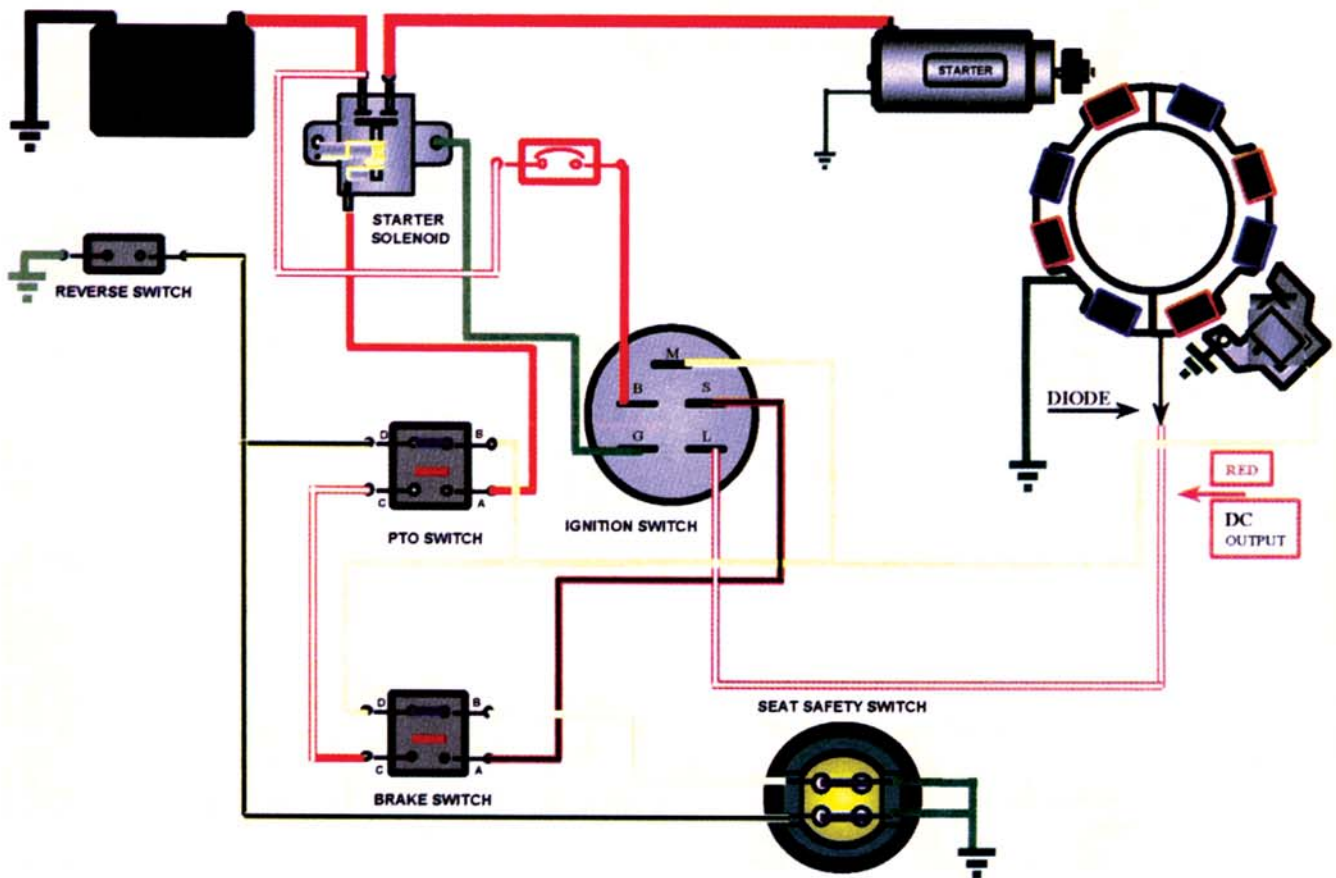


Figure 8-83.

# LEVELING THE CUTTING DECK

## NOTE

Prior to leveling the mowing deck, perform the following steps:

1. Check the tire pressure. The front tires will be approximately 14 psi, and the rear tires will be approximately 10 psi.
2. Place the tractor on a level surface.
3. Depress and lock the parking brake.
4. Raise the deck lift lever to the highest position.

### FRONT TO REAR ADJUSTMENT:

**IMPORTANT:** The front of the deck will be between 1/4" to 3/8" lower in the front than the rear of the deck.

1. Using a work glove or rag, rotate the blades until they are parallel with the tractor frame. See Figures 9-1 and 9-2.

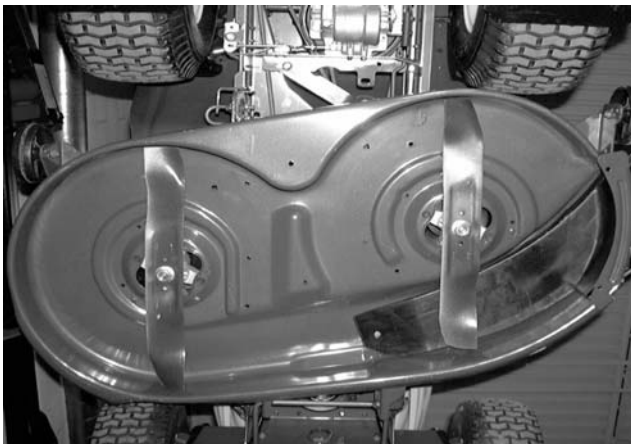


Figure 9-1.

2. Measure the front blade tips to ground.
3. Measure the rear blade tips to ground.
4. Make certain the front blade tips are 1/4" to 3/8" lower in the front than the rear blade tips.

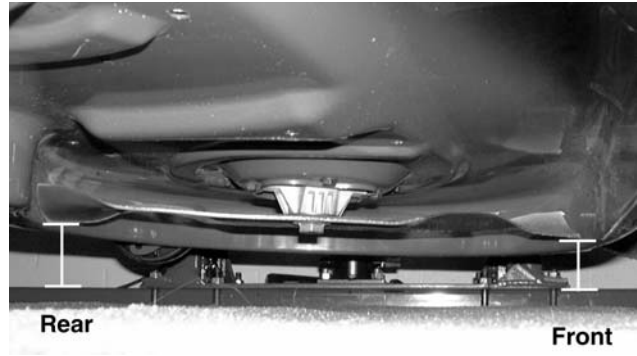


Figure 9-2.

## NOTE

If an adjustment is needed, perform the following steps:

5. Loosen both two jam nuts on the rear side of the deck stabilizer bracket using a 3/4" wrench. See Figure 9-3.

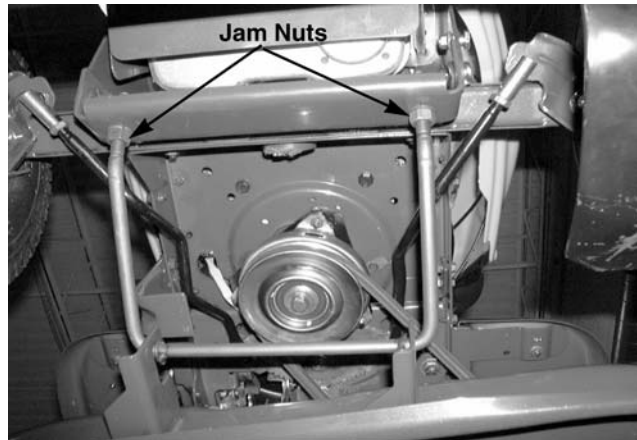


Figure 9-3.

6. Locate both lock hex nuts on the front side of the deck stabilizer bracket. See Figure 9-4.

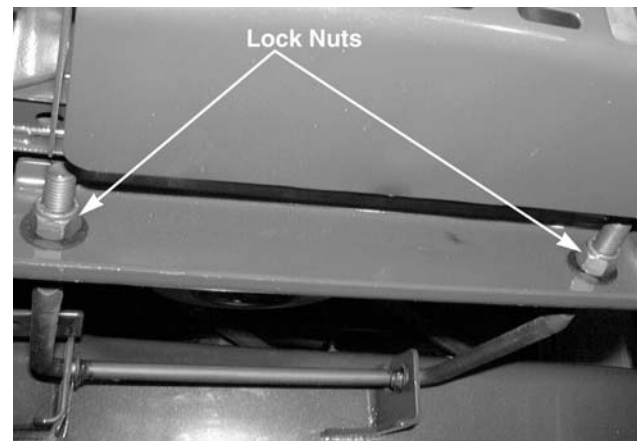


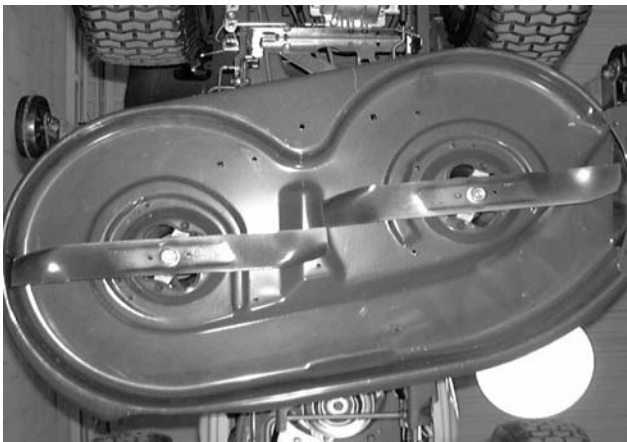
Figure 9-4.

7. Tighten both lock hex nuts to raise the front of the deck or loosen both lock hex nuts to lower the front of the deck using a 3/4" wrench.
8. Retighten both jam nuts on the rear side of the deck stabilizer when the proper adjustment has been achieved.

**SIDE TO SIDE ADJUSTMENT:**

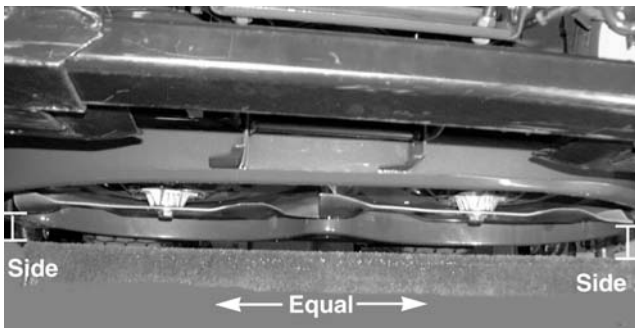
**IMPORTANT:** The cutting deck must be even side to side.

1. Using a work glove or rag, rotate the blades until they are cutting edge tip to cutting edge tip (perpendicular) to the tractor. See Figure 9-5.



**Figure 9-5.**

2. Measure the outer blade tips to ground. both measurements taken should be equal. See Figure 9-6.

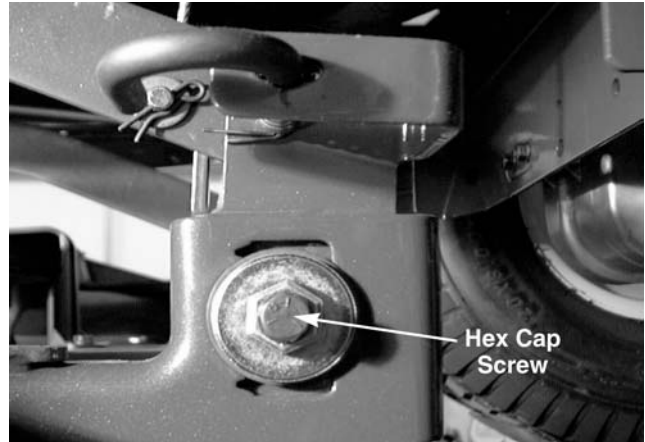


**Figure 9-6.**

**➔ NOTE**

If an adjustment is needed, perform the following steps:

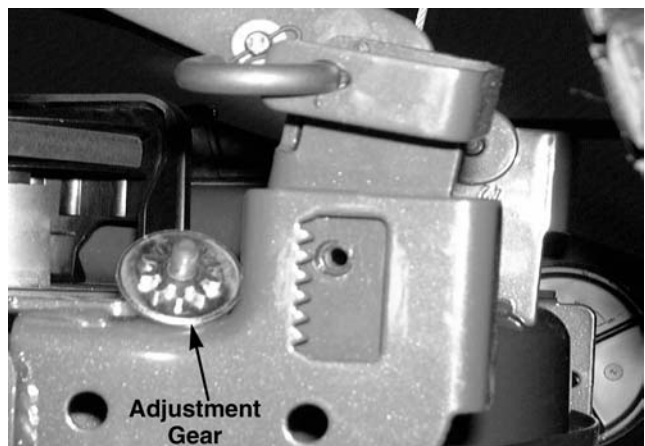
3. Loosen (DO NOT REMOVE) the hex cap screw on the left deck hanger bracket using a 1/2" and a 3/4" wrench. See Figure 9-7.



**Figure 9-7.**

4. Rotate the 3/4" deck adjustment gear right or left until the deck is level side to side and both blade tips to ground are equal in measurement.
5. Retighten the hex cap screw on the left deck hanger using a 1/2" and 3/4" wrench when the proper adjustment has been achieved.

**NEW ADJUSTMENT DESIGN**



**Figure 9-8.**

# DECK BELT REMOVAL AND INSTALLATION

## 42" CUTTING DECK

1. Lower the deck to the lowest position.
2. Pull the PTO idler pulley and bracket towards the discharge chute, relieving belt tension. See Figure 9-9.

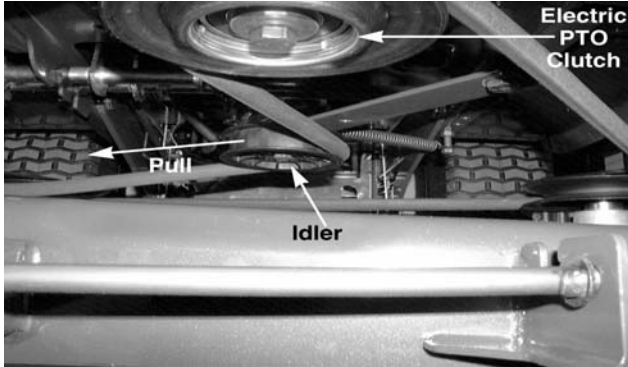


Figure 9-9.

3. Remove the deck belt from the electric PTO clutch on the engine.

4. Remove the self tapping screws securing the spindle belt covers. See Figure 9-10.

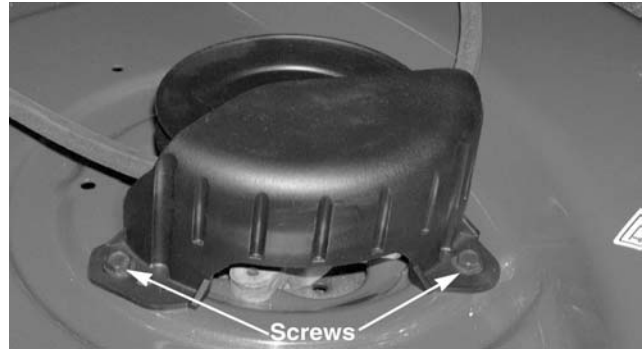


Figure 9-10.

5. Remove the spindle belt covers.
6. Remove the PTO deck belt.

**REINSTALL THE NEW BELT IN THE REVERSE ORDER ABOVE.**

## 46" CUTTING DECK

# CUTTING DECK REMOVAL

### Lower Belt

1. Pull the lower deck belt flat idler and idler bracket towards the left side of the tractor, relieving the belt tension. See Figure 9-11.
2. Remove the lower deck belt.
3. Lower the lift lever to the lowest setting.
4. Pull the PTO idler pulley and bracket towards the side discharge chute. See Figure 9-11.

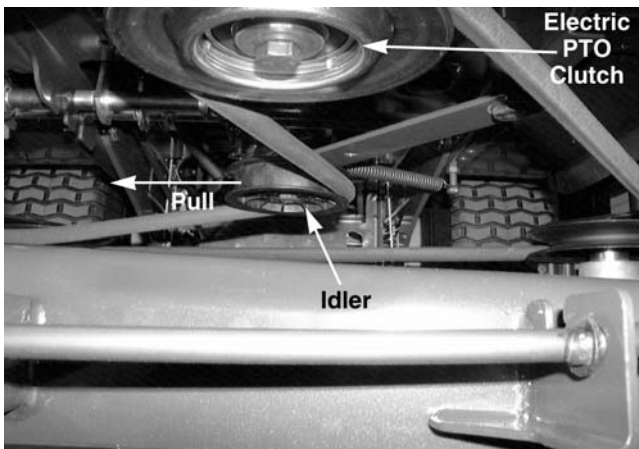


Figure 9-11.

5. Remove the deck belt from the lower pulley on the engine.

### NOTE

The 46" decks have an upper and a lower belt. The upper belt is removed for cutting deck removal.

6. Pull the rear deck support pins outward from the deck lift arms. See Figure 9-12.

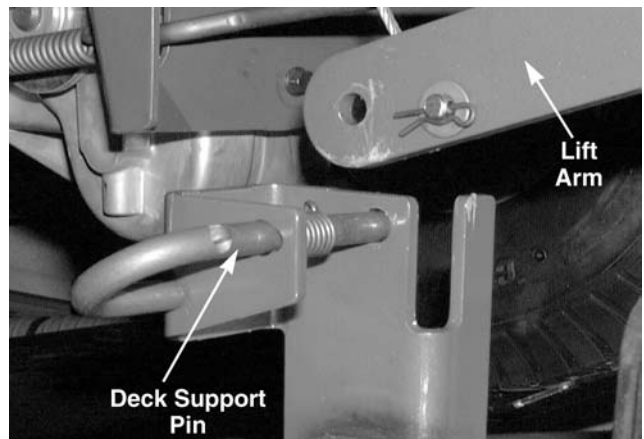


Figure 9-12.

7. Pivot the deck support pins to the rear.

8. Raise the lift lever to the highest setting. This will raise the lift arms up and out of the way of the deck assembly.
9. Slide the cutting deck forward and release the front deck hangers off of the front stabilizer rod. DO NOT DROP the deck to the ground. See Figure 9-13.



**Figure 9-13.**

10. Slide the deck towards the side discharge chute and remove it from the tractor.



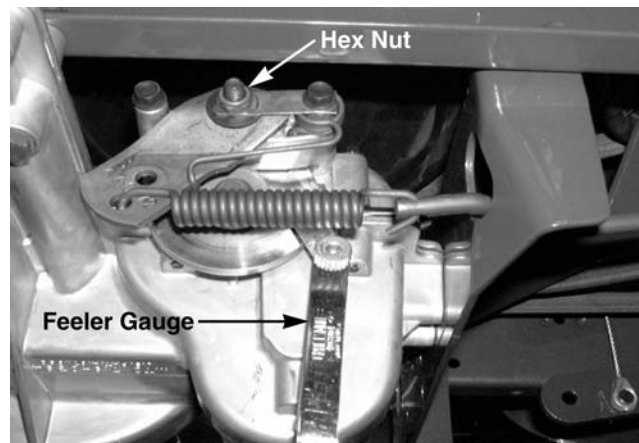
**CAUTION**

Remove the deck stabilizer assembly from the tractor prior to moving the unit.

## BRAKE ADJUSTMENTS

**IMPORTANT:** Make certain the tractor comes to a complete stop when the brake pedal is depressed. Also, make certain the rear wheels do not roll when the parking brake has been applied. If motion continues, perform the following steps:

1. Locate the hex nut that secures the brake assembly.
2. Loosen (DO NOT REMOVE) the hex nut using a 1/2" wrench.
3. Slide an .011" feeler gauge between the brake disc and the brake puck. See figure 9-14.



**Figure 9-14.**

4. Tighten the hex nut that secures the brake assembly.
5. Remove the .011" feeler gauge from the brake assembly.
6. Test for proper adjustments.

# AUTODRIVE PEDAL ADJUSTMENT

**IMPORTANT:** The AutoDrive pedal is properly adjusted when the hole found in the double-idler bracket has approximately 1-3/8" of travel with ten pounds of pressure applied to the AutoDrive pedal. See Figures 9-15 and 9-16.

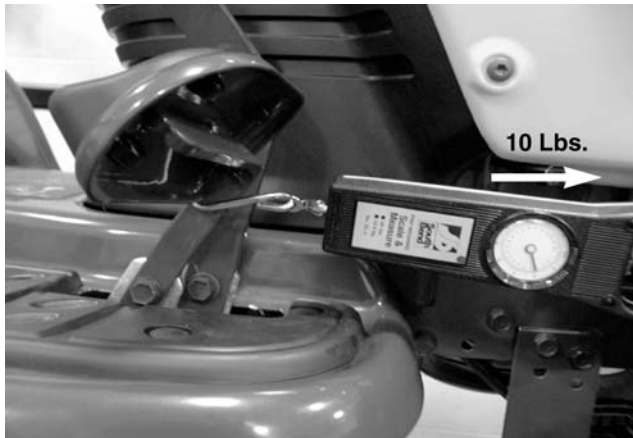


Figure 9-15

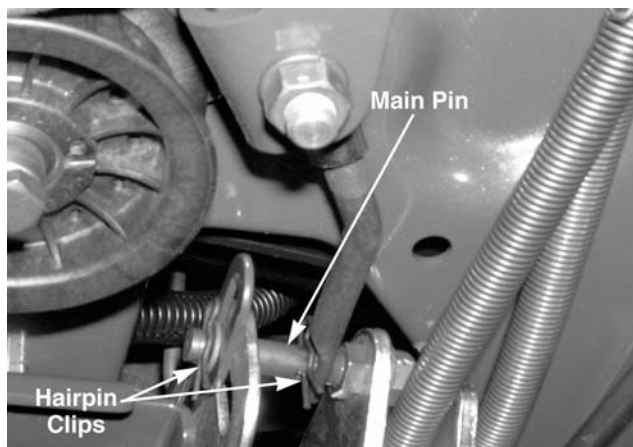


Figure 9-16

1. Locate the speed control assembly on the underside of the steering support bracket.

2. Remove both hairpin clips from the main pin on the speed control assembly. See Figure 9-17.

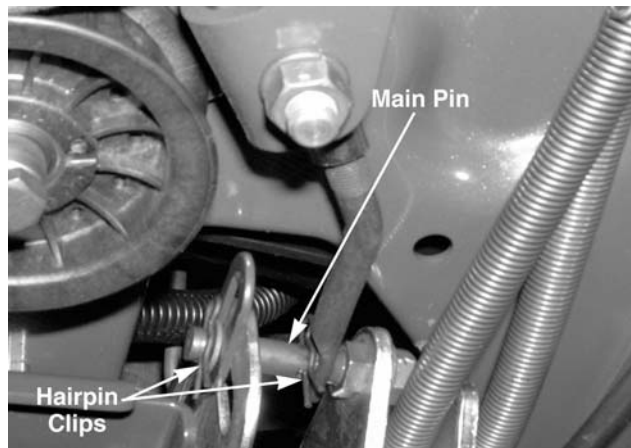


Figure 9-17

**NOTE**

Be careful not to lose the small flat washers found on the main pin.

**NOTE**

Make certain both hairpins are put back in from the top of the main pin during reassembly.

3. Remove the AutoDrive pedal return spring.
4. Using two 9/16" wrenches, remove the main pin from the speed control assembly.
5. Thread the idler adjustment rod inward or outward until the proper adjustment has been achieved.

**REASSEMBLE THE AUTODRIVE PEDAL IN THE REVERSE ORDER ABOVE.**

# DRIVE BELT REMOVAL AND REINSTALLATION

## TRANSMISSION BELT REMOVAL AND INSTALLATION

### Upper Belt

1. Raise the seat of the tractor and disconnect the battery cables from the battery. Remove the negative cable first. See Figure 9-18.

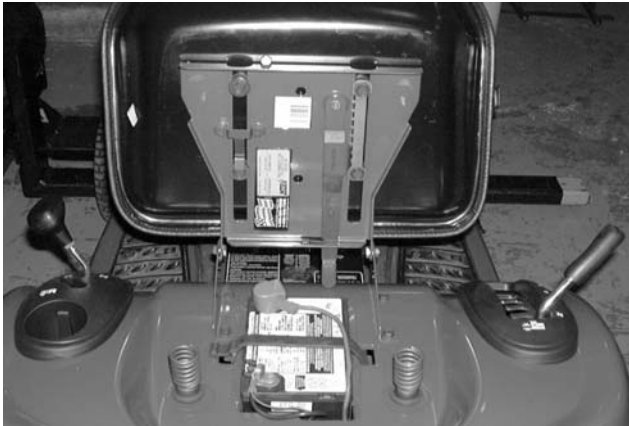


Figure 9-18

2. Remove the battery strap, battery, and the battery tray from the tractor. See Figure 9-19.



Figure 9-19

3. Raise the deck lift lever to the highest position.
4. Pull the transmission idler pulley towards the transmission and release the upper drive belt. See Figure 9-20.

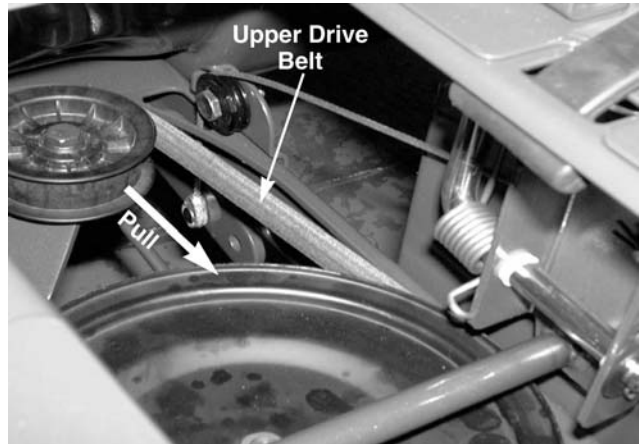


Figure 9-20

5. Slowly release the idler pulley.
6. Remove the upper drive belt from the transmission pulley and the variable-speed pulley. See Figure 9-21.

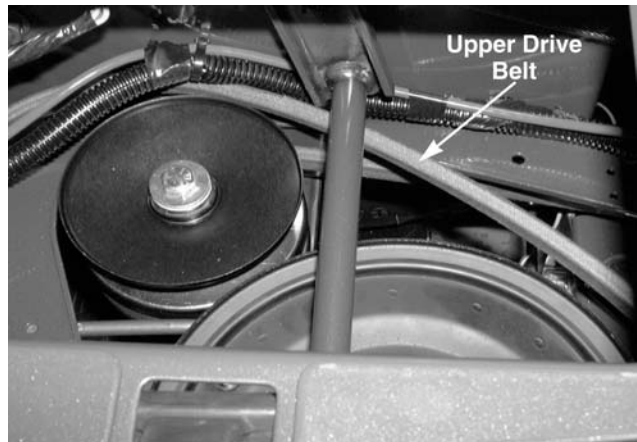


Figure 9-21

### NOTE

Slowly roll the drive belt off of the variable speed pulley.

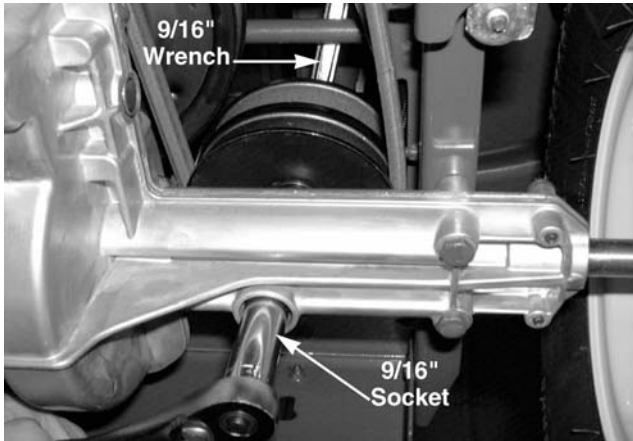
## VARIABLE-SPEED BELT REMOVAL AND REINSTALLATION

### Lower Belt

**IMPORTANT:** Prior to lower variable speed belt removal, perform cutting deck removal and upper drive belt removal.

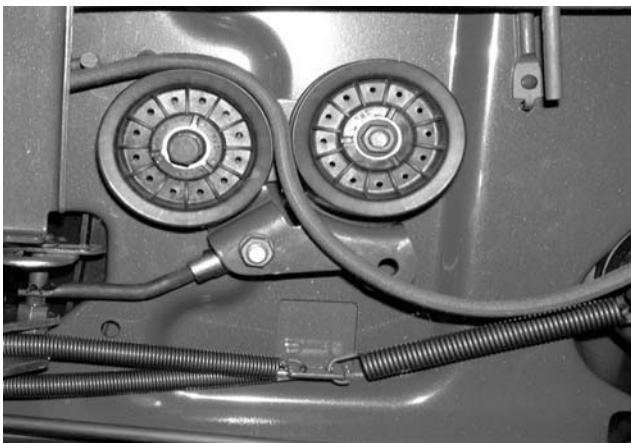


1. Remove the hex bolt and lock nut securing the variable-speed pulley to the transmission using a 9/16" socket and a 9/16" wrench. See Figure 9-22.



**Figure 9-22**

2. Raise the variable speed pulley and roll the lower drive belt off.
3. Remove the variable-speed pulley from the tractor through the battery box opening.
4. Disconnect the wiring harness female connector from the reverse safety switch.
5. Loosen (DO NOT REMOVE) the flat moving idler on the double-idler bracket. See Figure 9-23.



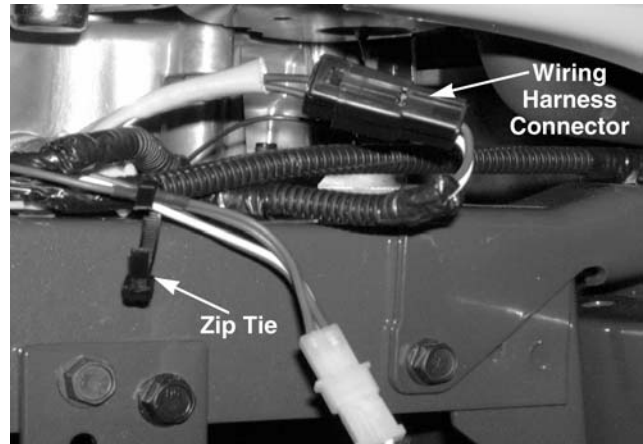
**Figure 9-23**

6. Remove the variable-speed belt from the double idler pulley assembly.
7. Cut and remove the zip tie securing the PTO clutch wires to the wiring harness.

**NOTE**

Make certain a new zip tie is reinstalled during reassembly.

8. Carefully disconnect the wiring harness connector from the electric PTO clutch assembly. See Figure 9-24.



**Figure 9-24**

**NOTE**

During reassembly, make certain the PTO clutch wires are routed inside the right hand drag link.

9. Remove the hex bolt that secures the electric PTO clutch to the engine crank shaft using a 5/8 socket.

**NOTE**

- 1: Some units have a washer that rests on top of the electric PTO clutch, make certain it is in place during reassembly.
- 2: Torque the hex bolt to 38 to 50 foot-pounds during reassembly.
- 3: Make certain that the clutch retaining pin is in the electric PTO clutch bracket during reassembly.

10. Slowly lower the engine drive pulley and remove the variable-speed belt. See Figure 9-25.



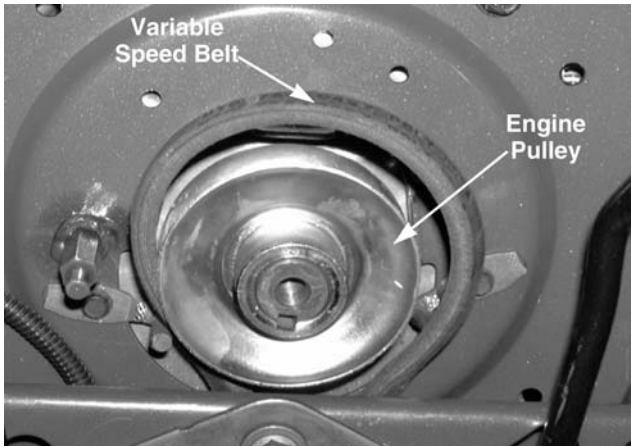


Figure 9-25

**➔ NOTE**

Carefully set the engine drive pulley aside, making certain the 1/4" squared key remains in place.

11. Remove the variable-speed belt from the tractor.

**REINSTALL THE VARIABLE-SPEED BELT IN THE REVERSE ORDER ABOVE.**

## TRANSMISSION REMOVAL AND INSTALLATION

**➔ NOTE**

Prior to performing transmission removal and installation, it is necessary to remove the upper drive belt.

1. Remove both rear hub caps from the rear wheel assemblies.
2. Loosen both hex cap screws securing the rear wheel assemblies to the axles.
3. Raise the rear of the tractor off the ground.
4. Remove both center hex cap screws and bell washers from the rear wheel assemblies.
5. Remove both rear wheel assemblies from the tractor.
6. Disconnect the reverse safety switch. See Figure 9-26.

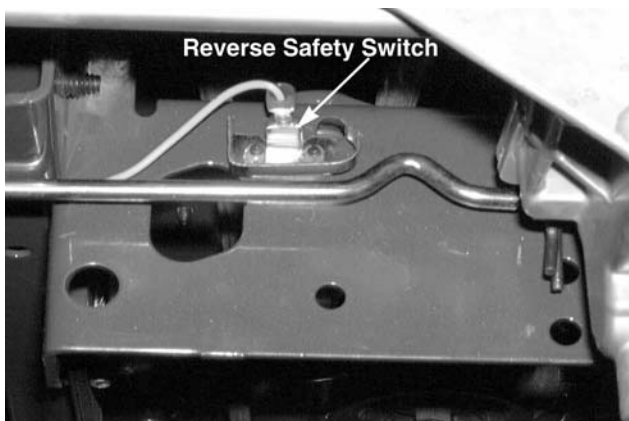


Figure 9-26

7. Remove the hair pin that secures the shift linkage to the shift fork and set the shift linkage aside. See Figure 9-27.

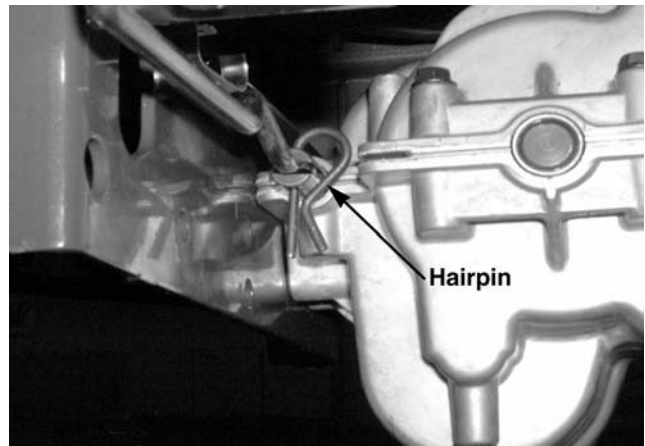
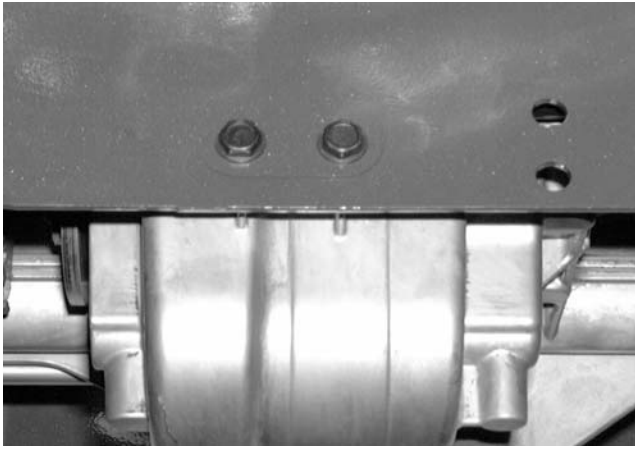


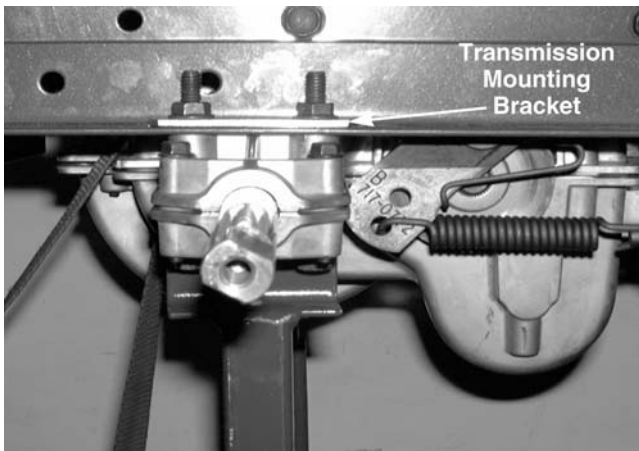
Figure 9-27

8. Remove both of the self tapping screws that secure the transmission to the front torque bracket using a 3/8 socket. See Figure 9-28.



**Figure 9-28**

9. Support the bottom of the transaxle.
10. Remove all four hex bolts and lock nuts securing the transmission to the frame using a 1/2" socket and a 1/2" wrench. See Figure 9-29.



**Figure 9-29**

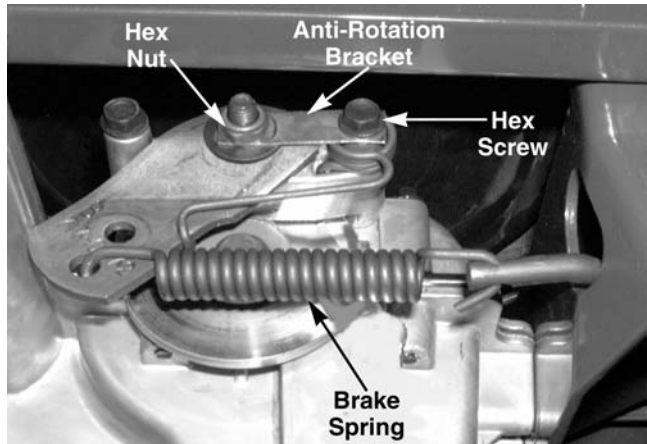
11. Remove both transmission mounting brackets from the top of the frame.
12. Remove the hex bolt and lock nut securing the variable-speed pulley to the transmission using a 9/16 socket and a 9/16 wrench.
13. Remove the locking hex nut from the brake actuation arm on the transmission. See Figure 9-30.

**➡ NOTE**

During reassembly, perform the brake adjustment section.

14. Loosen (DO NOT REMOVE) the hex washer head self-tapping screw that secures the anti-

rotation bracket to the brake assembly using 3/8 wrench. See Figure 9-30.



**Figure 9-30**

15. Pivot the anti-rotation bracket down and relieve the spring tension on the brake actuation arm.
16. Remove the flat washer from the actuation arm stud of the brake assembly.
17. Remove the brake spring from the brake actuation arm. See Figure 9-30.
18. Slowly lower the transmission from the tractor. See Figure 9-31.



**Figure 9-31**

**➡ NOTE**

The variable-speed pulley will be hanging by the drive belt at this time. Set it aside after removal of the transmission.

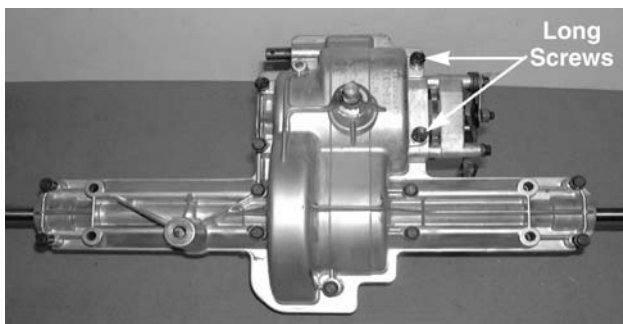
**INSTALL THE TRANSMISSION IN THE REVERSE ORDER ABOVE.**

# TRANSMISSION DISASSEMBLY AND REASSEMBLY

1. Remove the hex nut and bell washer that secures the transmission pulley to the input shaft using an 11/16 socket.
2. Remove the transmission pulley from the input shaft.
3. Remove all the self tapping screws that secure the two transmission case halves together using a 3/8 socket. See Figure 9-32.

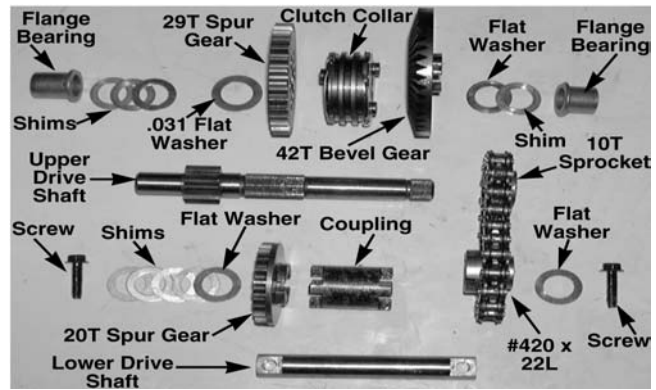
**NOTE**

The two long self tapping screws secure the brake area.



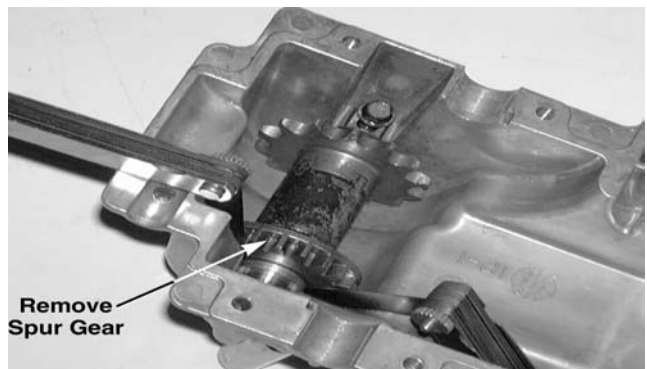
**Figure 9-32**

4. Separate the upper transmission housing from the lower transmission housing and set it aside.
5. Remove the differential axle assembly from the lower housing.
6. Remove the shift fork assembly, detente ball and spring.
7. Remove both self tapping screws securing the lower drive shaft to the lower transmission housing using a 3/8 socket and a 6" extension.
8. Remove the upper and lower drive shaft assemblies as one unit from the lower transmission housing.
9. Remove and inspect all components of the upper and lower drive shafts. See Figure 9-33.



**Figure 9-33**

10. Reassemble the lower drive shaft assembly (ONLY) and place it into the lower transmission housing. Secure the lower drive shaft in place with both self tapping screws using a 3/8 socket and a 6" extension.
11. Place two feeler gauges between the reverse spur gear and the flat washer shim. See Figure 9-34.



**Figure 9-34**

**NOTE**

Make certain the tolerance is between .007" and .015".

12. Remove the lower shaft assembly from the lower transmission housing using a 3/8 socket and a 6" extension.
13. Reassemble the upper drive shaft assembly (ONLY) and place it into the lower transmission housing. Make certain the bushing detents are sitting firmly into the housing.

- Place two feeler gauges between the chain sprocket and the flat washer shim. See Figure 9-35.

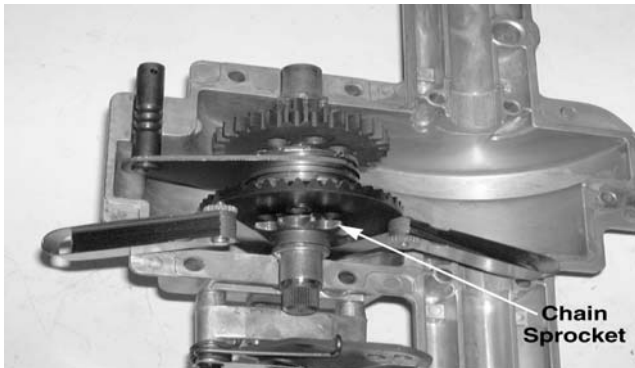


Figure 9-35

➡ NOTE

Make certain the tolerance is between .007" and .015".

- Place two feeler gauges between the gear on the upper drive shaft and the flat washer shim. See Figure 9-36.

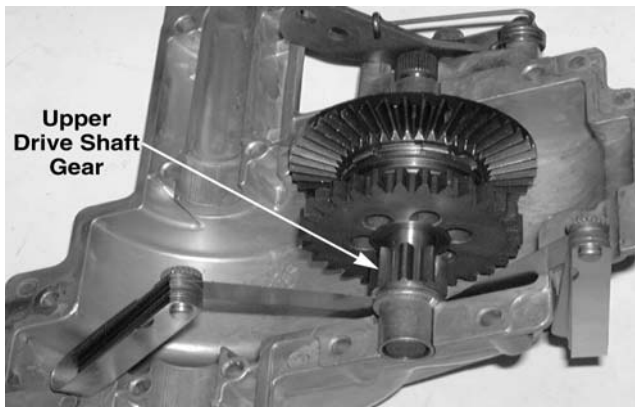


Figure 9-36

➡ NOTE

Make certain the tolerance is between .007" and .015".

- Place two feeler gauges between the top of the upper housing and the flat washer on the input shaft. See Figure 9-37.

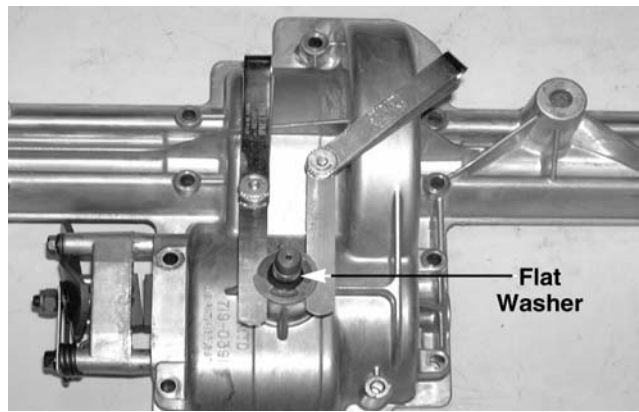


Figure 9-37

➡ NOTE

Make certain the tolerance is between .007" and .015".

- Lubricate all shafts with Never Seez and reassemble the components of the transmission in the lower housing.
- Fill the transmission with 20 ounces of grease, part #737-0148.
- Place the upper transmission housing over the lower housing and secure them together with the self tapping screws removed earlier, using a 3/8 socket. See Figure 9-38.

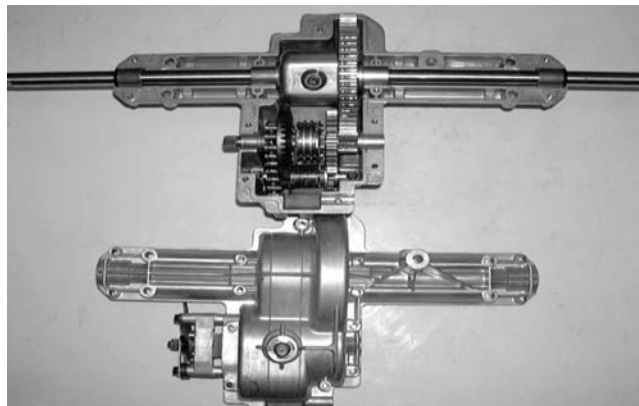


Figure 9-38

**IMPORTANT:** Remember to install the two longest self tapping screws in the brake assembly area.

- Torque all perimeter case half self tapping screws between 90 and 110 inch-pounds using a 3/8 socket and a torque wrench. See Figure 9-39.

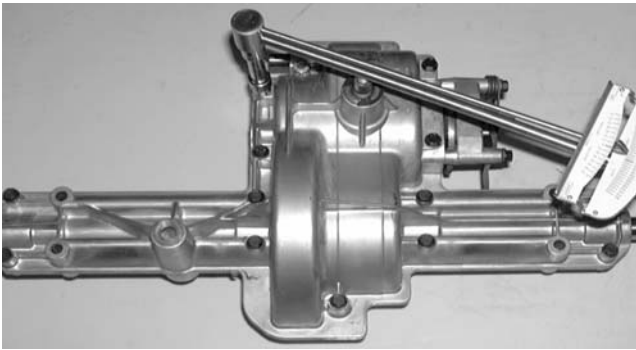


Figure 9-39

**REASSEMBLE ALL COMPONENTS IN THE REVERSE ORDER ABOVE.**

## DRIVE BELT REMOVAL

1. Coming in from below the left foot board, locate the stationary "V" idler.
2. Grasp the left frame rail and "V" belt on both sides of the "V" idler.
3. Squeeze both hands and release the "V" belt from the "V" idler.
4. Release the "V" belt slowly. See Figure 9-40.

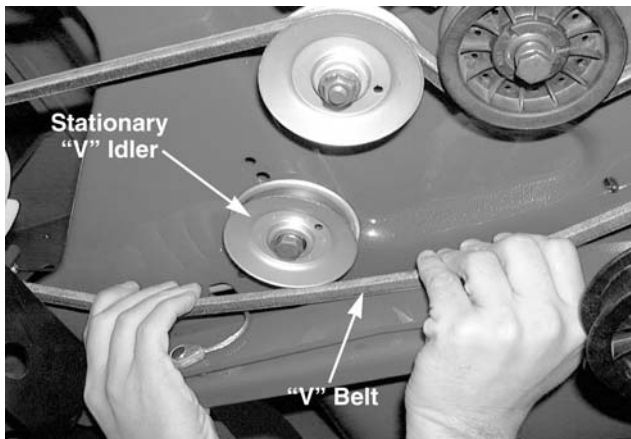


Figure 9-40

5. Push forward lightly on the double idler bracket assembly and remove the extension spring from the fixed frame bolt.
6. Remove the extension spring from the double idler bracket assembly and set it aside. See Figure 9-41.

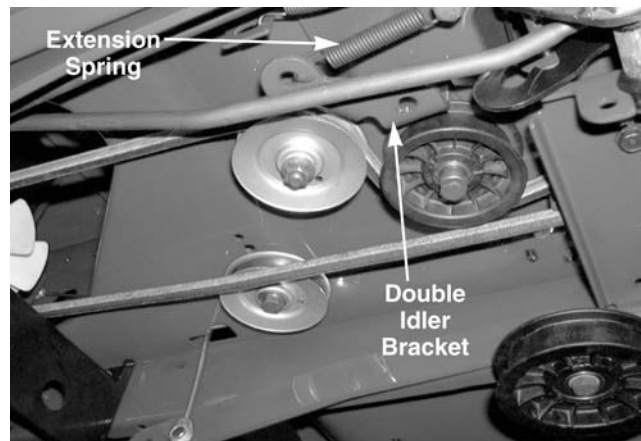


Figure 9-41

7. Roll the "V" belt out of both the "V" idler and the flat idler on the double idler bracket assembly. See Figure 9-42.

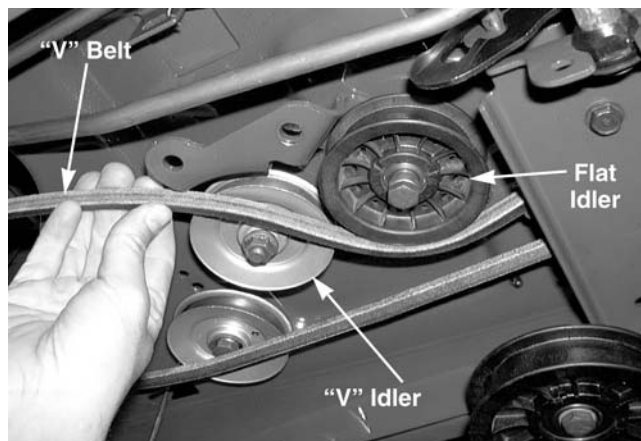


Figure 9-42

8. Grasp the electric PTO clutch and remove the hex bolt securing it to the crank shaft using a 5/8 socket. See Figure 9-43.

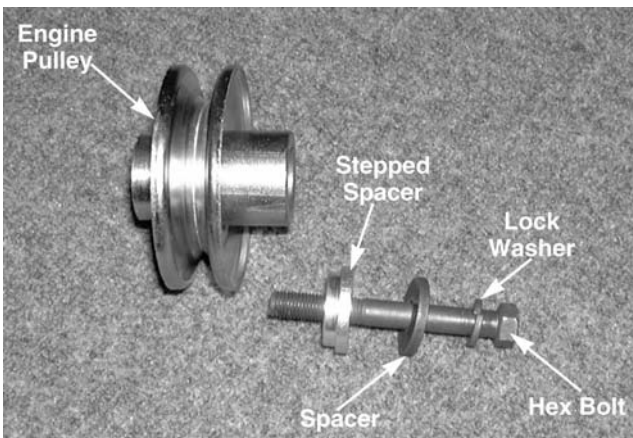


**Figure 9-43**

9. Set the hex bolt and hardware aside.

**NOTE**

The order of the hardware is as follows: hex bolt, lock washer, spacer, and stepped spacer. See Figure 9-44.



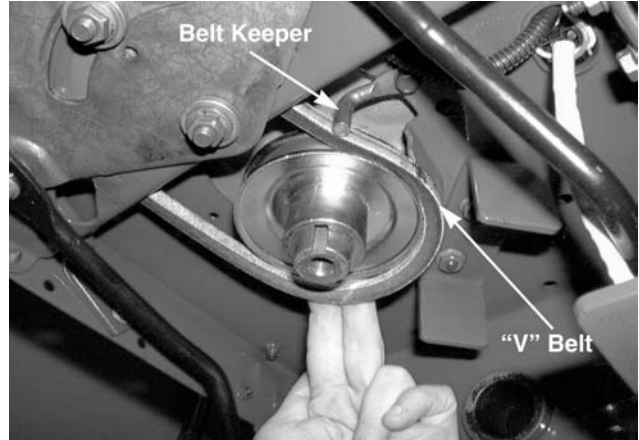
**Figure 9-44**

10. Slowly lower the electric PTO and secure it.

**NOTE**

Make certain the electric PTO is NOT hanging on the harness wires.

11. Grasp the drive pulley and pull downward until the "V" belt is clear of the belt keepers at the engine. See Figure 9-45.



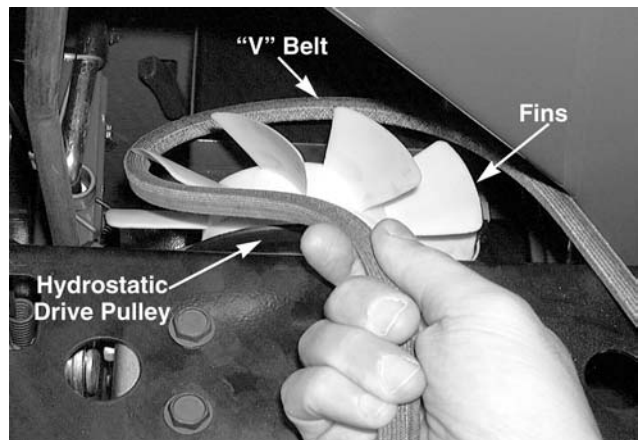
**Figure 9-45**

12. Roll the drive belt off of the drive pulley at the engine and set the drive pulley aside.

**NOTE**

The drive pulley goes on the crankshaft thin side up, and has a separate key.

13. Pull the "V" belt down and to the back side of the crankshaft.
14. Pull the "V" belt rearward towards the hydrostatic transmission.
15. Remove the "V" belt from around the hydrostatic drive pulley. See Figure 9-46.



**Figure 9-46**

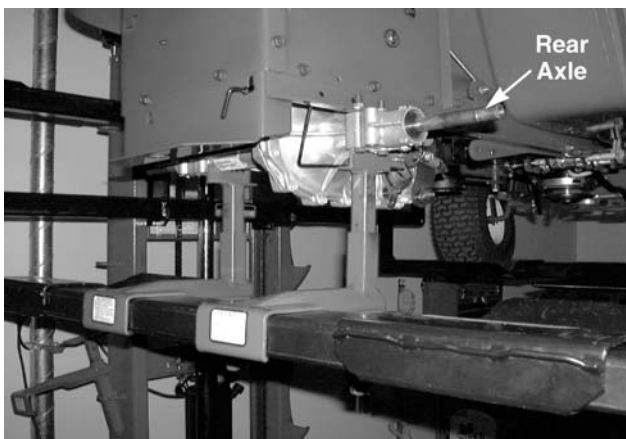
**➡ NOTE**

The fins on the hydrostatic fan are slightly flexible and can be bent down cautiously to remove the "V" belt.

**INSTALL THE DRIVE BELT IN THE REVERSE ORDER ABOVE.**

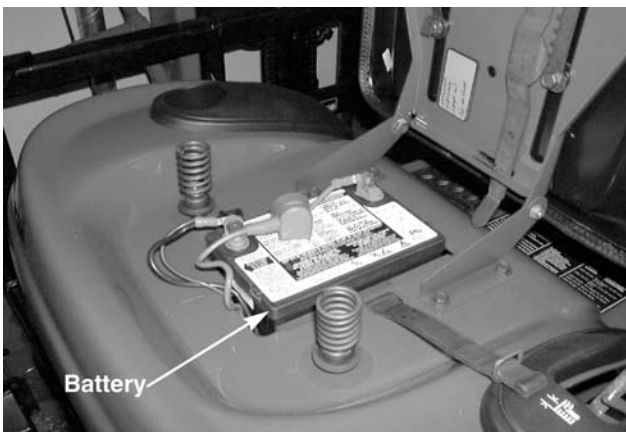
## HYDROSTATIC TRANSMISSION REMOVAL

1. Raise the rear wheels off the ground.
2. Support the hydrostatic transmission from below.
3. Remove both hex bolts and belleville washers securing the rear wheel assemblies to the rear axles using a 1/2" socket and extension. See Figure 9-47.



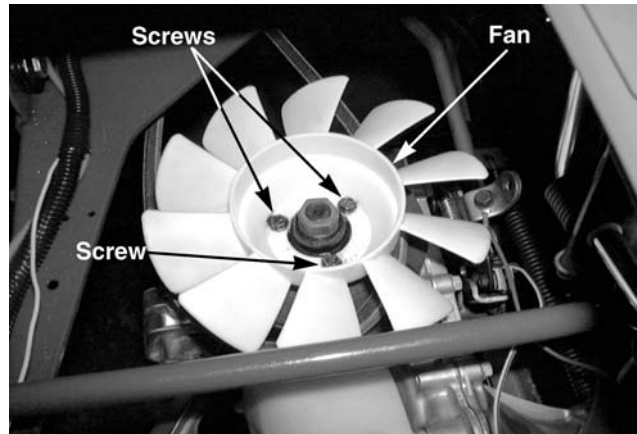
**Figure 9-47**

4. Remove the rear wheel assemblies.
5. Raise the seat.
6. Remove the battery cables from the battery terminals using a 7/16 wrench.
7. Remove the battery and battery tray from the tractor. See figure 9-48.



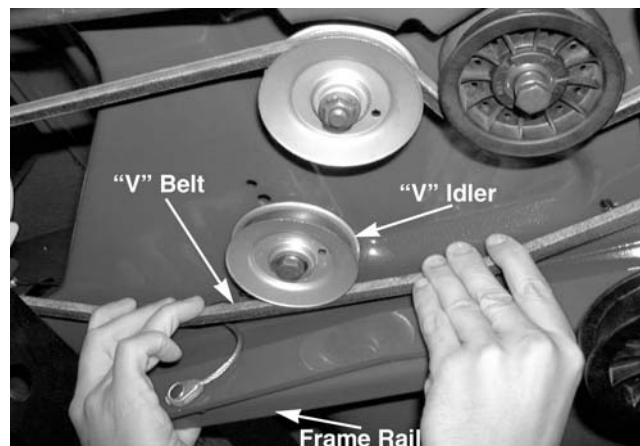
**Figure 9-48**

8. Remove all three self tapping screws securing the hydrostatic fan to the hydrostatic drive pulley using a 5/16 socket.
9. Remove the hydrostatic fan. See figure 9-49.



**Figure 9-49**

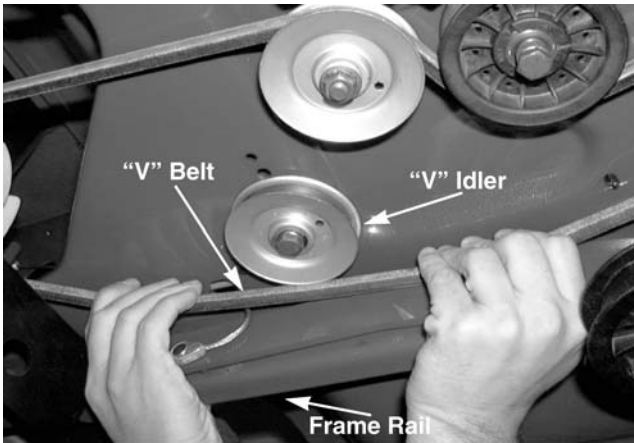
10. Coming in from below the left foot board, locate the stationary "V" idler.
11. Grasp the left frame rail and "V" belt on both sides of the "V" idler. See Figure 9-50.



**Figure 9-50**

12. Squeeze both hands and release the "V" belt from the "V" idler. See Figure 9-51.





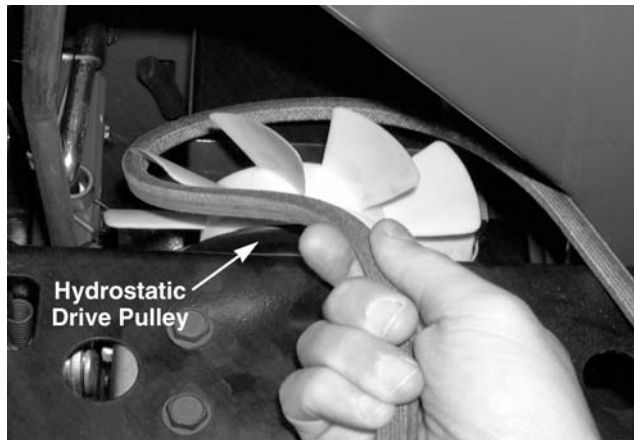
**Figure 9-51**

13. Release the "V" belt slowly. See Figure 9-52.



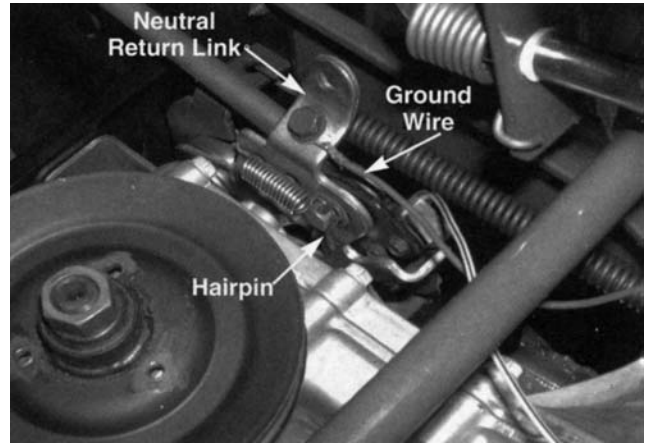
**Figure 9-52**

14. Roll the "V" belt off of the hydrostatic drive pulley. See Figure 9-53.



**Figure 9-53**

15. Remove the hairpin securing the hydrostatic foot control rod ferrule and reverse safety bracket to the neutral return plate. See Figure 9-54.

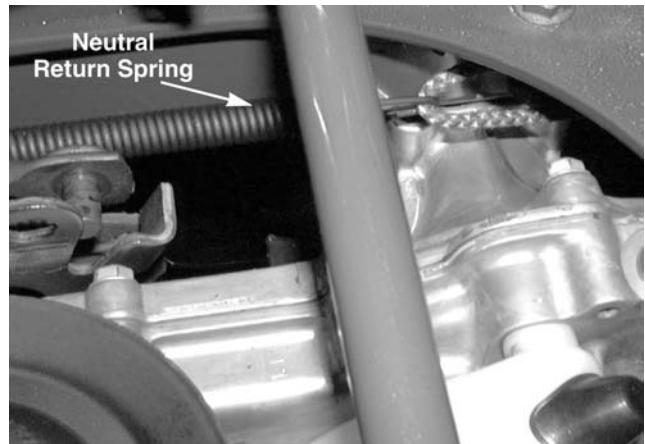


**Figure 9-54**

**NOTE**

Make certain the small extension spring is properly installed during reinstallation.

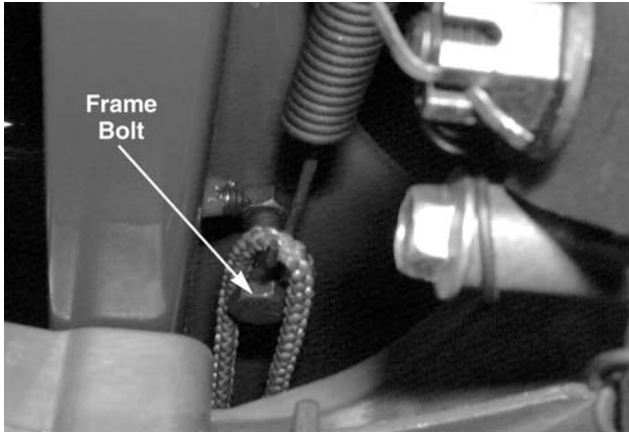
16. Remove the self tapping screw securing the ground wire to the neutral return link. See Figure 9-55.



**Figure 9-55**

17. Remove the neutral return spring from the frame bolt using a piece of recoil rope. See Figure 9-56.



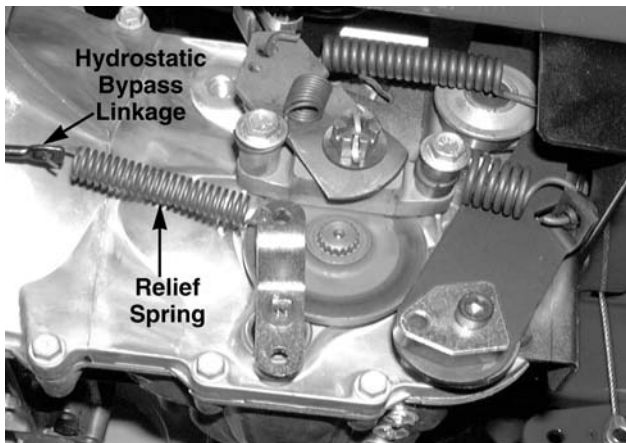


**Figure 9-56**

**➡ NOTE**

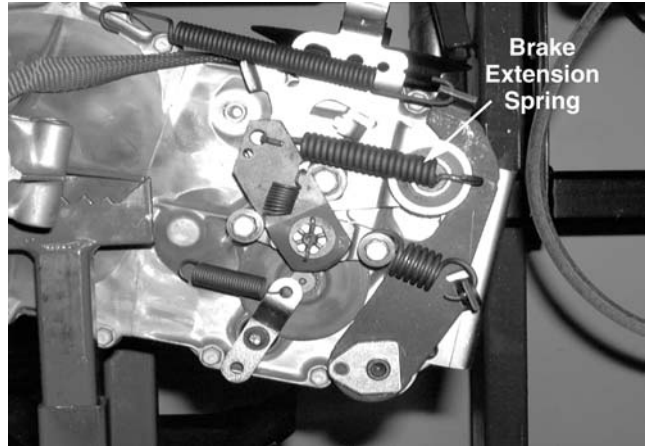
An assistant may be necessary during reinstallation to guide the extension spring back onto the frame bolt. See Figures 9-55 and 9-56.

18. Remove the hydrostatic relief spring from the hydrostatic bypass linkage and set it aside. See Figure 9-57.



**Figure 9-57**

19. Remove the brake extension spring from the brake rod using a pair of vice grips. See Figure 9-58.

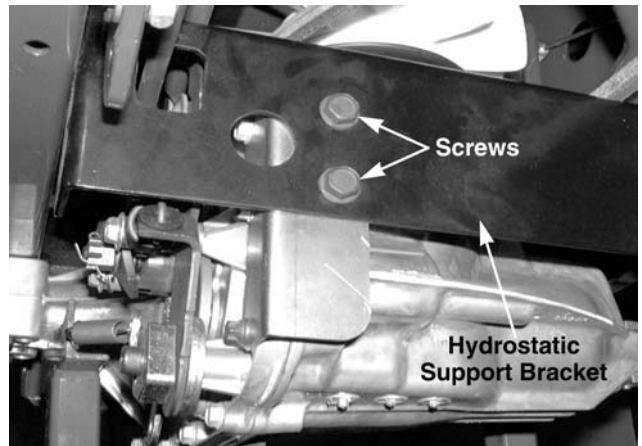


**Figure 9-58**

**➡ NOTE**

Insert the brake extension spring into the brake rod before installing the hydrostatic transmission.

20. Remove both self tapping screws securing the front of the hydrostatic transmission to the front hydrostatic support bracket using 1/2" socket. See Figure 9-59.



**Figure 9-59**

21. Secure the front of the hydrostatic transmission to make certain it does not tip forward during lowering.
22. Remove all four hex bolts and lock nuts securing the hydrostatic transmission to the frame rails using a 1/2" socket and a 1/2" wrench. See Figure 9-60

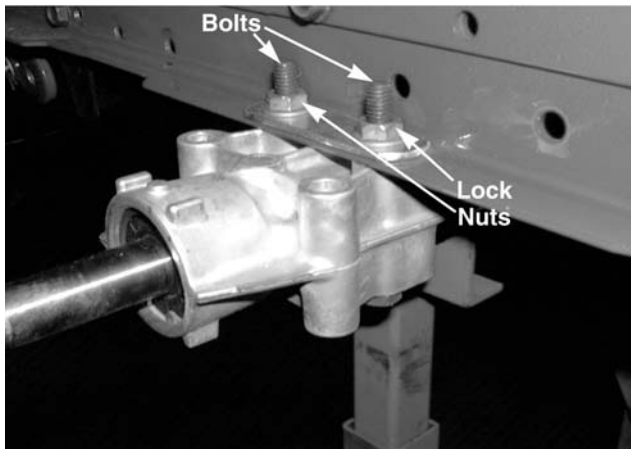


Figure 9-60

23. Secure the tractor frame. See Figure 9-61.

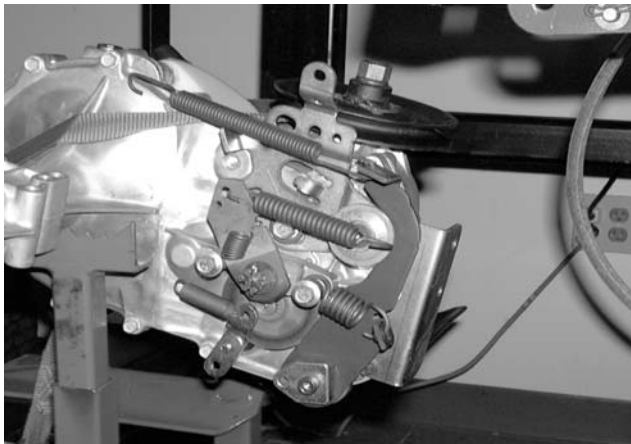


Figure 9-61

24. Slowly lower the hydrostatic transmission from the tractor. See Figure 9-62.

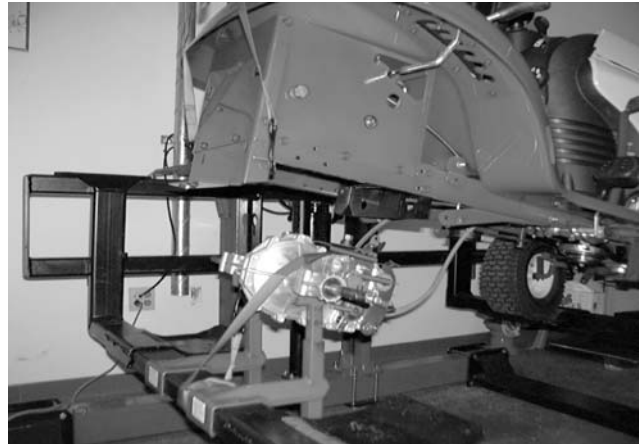


Figure 10-62

**REINSTALL THE HYDROSTATIC TRANSMISSION IN REVERSE ORDER ABOVE.**

## STEERING ADJUSTMENTS

**IMPORTANT:** The front tires will have a "TOE-IN" between 1/16" and 5/16" to allow the unit to track properly.

1. Check the tire pressure in the front tires and make certain that they are at approximately 14 PSI.
2. Place the unit on level ground.
3. Place the steering wheel in the straight forward position.
4. Lower the deck lift lever to the lowest position.
5. Line up the centering hole in the steering gear with the centering hole in the support plate, and insert a 1/4" Phillips screw driver up through both. See Figure 9-63.

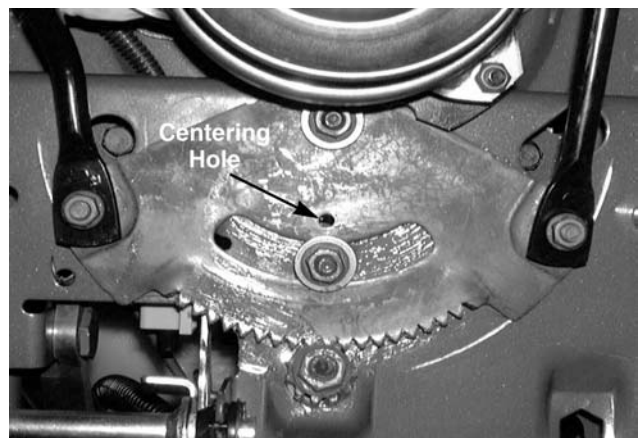


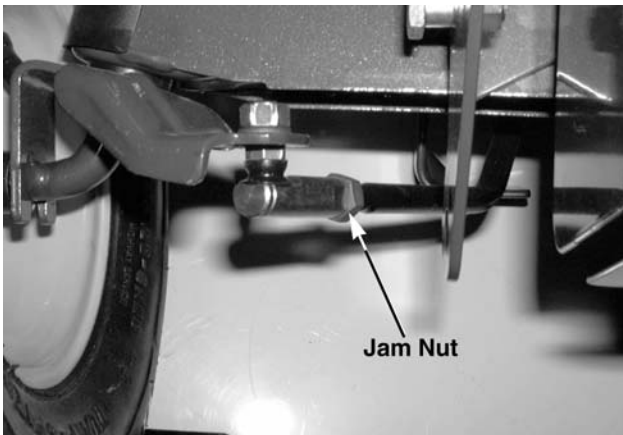
Figure 9-63

6. In front of the axle, measure the distance horizontally from the inside of the left rim to the inside of the right rim. See Figure 9-64.



**Figure 9-64**

7. From behind the axle, measure the distance horizontally from the inside of the left rim to the inside of the right rim.
8. The measurement taken in front of the axle should be between 1/16" and 5/16" less than the measurement taken behind the axle. If not, perform the following steps:
9. Loosen the jam nut at the rear of the right ball joint that secures the ball joint to the drag link using a 1/2" wrench and an 11/16" wrench. See Figure 9-65.



**Figure 9-65**

10. Remove the hex nut and lock washer that secures the right ball joint to the right axle assembly using a 1/2" wrench and a 9/16" wrench.
11. Remove the right hand ball joint from the right hand drag link.
12. Remove the left hand ball joint performing steps 9, 10, and 11 above.
13. Place the left and right tire assemblies in the straight forward position.
14. Set the toe-in for the rim assemblies to the proper measurements as described in steps 6, 7, and 8 above.
15. Thread the right hand ball joint onto the right hand drag link until the mounting hole in the right hand axle assembly lines up with the ball joint.

**➡ NOTE**

Count the number of turns the ball joint was rotated onto the drag link. This number should be equal for the left side as well.

16. Secure the right hand ball joint to the right hand axle assembly with the lock washer and nut removed earlier, using a 1/2" wrench and a 9/16" socket.
17. Secure the right hand ball joint jam nut to the right hand drag link using a 1/2" wrench and an 11/16" wrench.
18. Install the left hand ball joint using steps 15, 16, and 17.

**➡ NOTE**

Make certain the same amount of rotations are used on the left ball joint as the right ball joint.

# ELECTRICAL SECTION

## ➔ NOTE

A multimeter is a must for this section. If any of the following tests do not match, repair that portion of the system.

### BRAKE SWITCH

**IMPORTANT:** The fuel tank has been removed for clarity.

1. Locate and remove the brake safety interlock switch from the metal frame tab. See Figure 9-66.

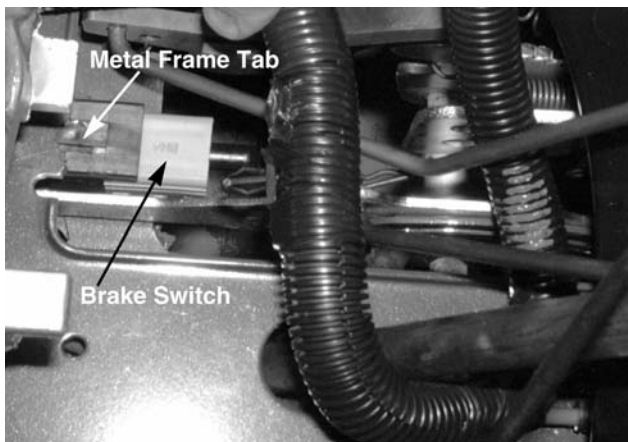


Figure 9-66

## ➔ NOTE

The brake switch has a center locking tab that must be dislodged from the metal frame tab.

2. Pull the wiring harness connector and brake switch forward and slide it toward the right frame rail. See Figures 9-67 and 9-68.

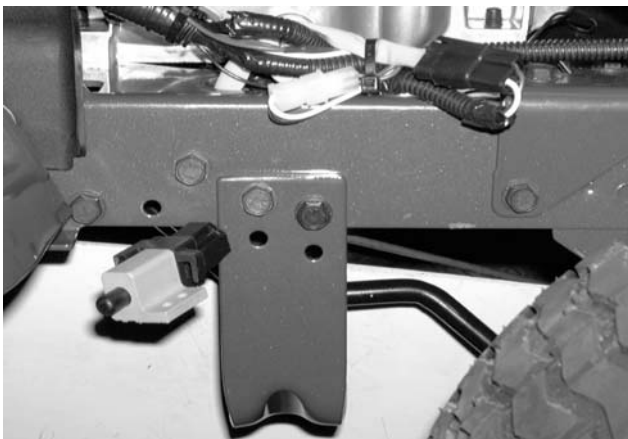


Figure 9-67

3. Remove the brake safety switch from the wiring harness connector. See Figure 9-68.

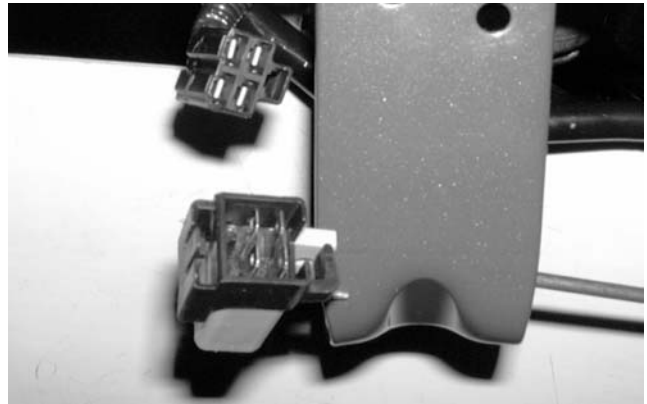


Figure 9-68

4. Place the multimeter in the **OHM's** mode.
5. Place both probes of the multimeter on the NC (normally closed) terminals and test for continuity. –There will be **CONTINUITY**. See Figure 9-69.

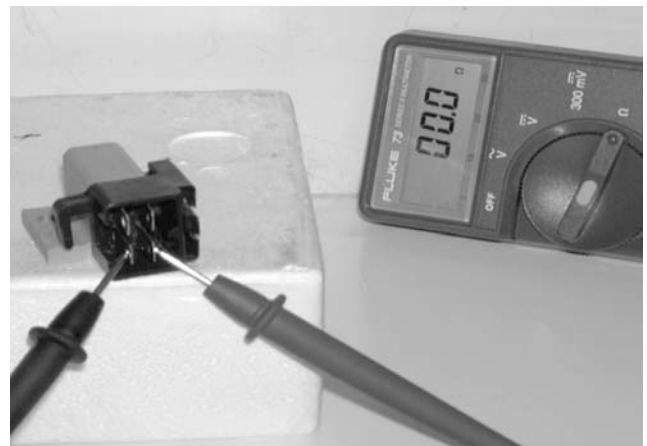
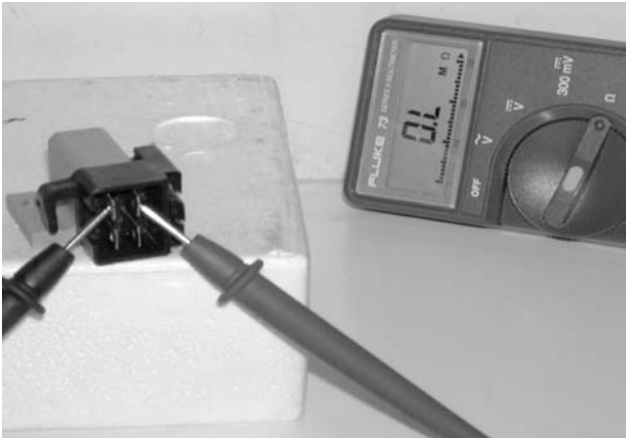


Figure 9-69

6. Place both probes on the NO (normally open) terminals and test for continuity. –There will be **NO CONTINUITY**. See Figure 9-70.



**Figure 9-70**

- Depress the plunger and perform steps 5 and 6.

**NOTE**

The **NC** (normally closed) terminals will not have continuity. The **NO** (normally open) terminals will have continuity.

**SEAT SAFETY SWITCH**

**NOTE**

The seat safety switch is mounted directly below the left seat compression spring assembly.

- Raise the seat.
- Remove the negative and positive battery cables from the battery.

**NOTE**

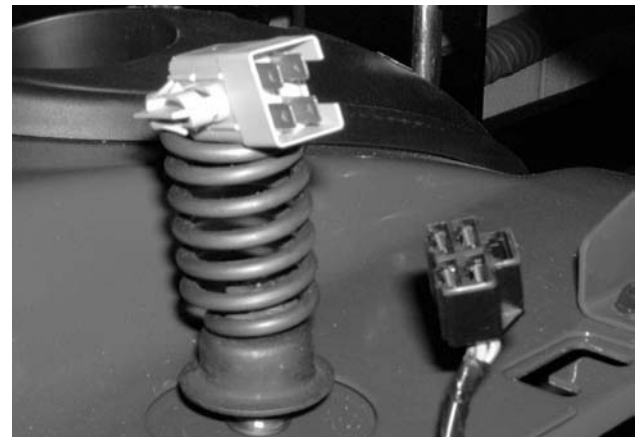
For safety, remove the negative terminal first.

- Remove the battery strap, battery, and battery tray from the tractor.
- Reach in through the battery opening and squeeze the locking clips together on the seat switch. See Figure 9-73.
- Remove the seat switch from the frame holding bracket. See Figure 9-71.



**Figure 9-71**

- Disconnect the wiring harness connector from the seat switch. See Figure 9-72.



**Figure 9-72**

- Set the seat safety switch on a flat surface. This is the at rest position. See Figure 9-73.



**Figure 9-73**

- Place the multimeter in the **OHM's** mode.

- Place both probes of the multimeter on the lower NC (normally closed) terminals and test for continuity.  
–There will be **CONTINUITY**. See Figure 9-74.



Figure 9-74

- Place both probes on the second set of upper NC (normally closed) terminals.  
–There will be **CONTINUITY**. See Figure 9-75.



Figure 9-75

- Depress the plunger and perform steps 9 and 10.

**NOTE**

Both sets of NC terminals will not have continuity.

**ELECTRIC PTO SWITCH**

**IMPORTANT:** The electric PTO switch is three small switches bundled into one. The PTO switch consists of nine total terminal positions (three sets of three terminals) on the back side. Seven of these terminals have male spades. Two terminals do not have male spades because they are not used in our applications.

**NOTE**

Remove all four self tapping screws securing the fuel tank to the dash panel using a 1/2" socket. Lower the fuel tank out of the way.

- Locate and remove the PTO switch and wiring harness connector. See Figure 9-76.

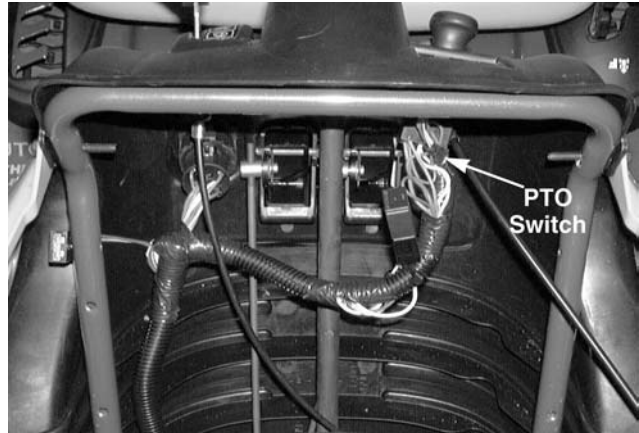


Figure 9-76

- Remove the wiring harness connector from the PTO switch.
- Make certain the PTO switch is in the **OFF** (closed) position.
- Looking at the back side of the PTO switch, find the male terminals that are nearest the steering column. There will be a terminal on each side and no terminal in the center... **XOX**.
- Using an ohm meter, place the test probes on the outer two terminals. This is the start circuit.  
–There will be **CONTINUITY**. See Figure 9-77.



Figure 9-77

- Pull the PTO switch to the ON position.  
–There will be **NO CONTINUITY**. See Figure 9-78.

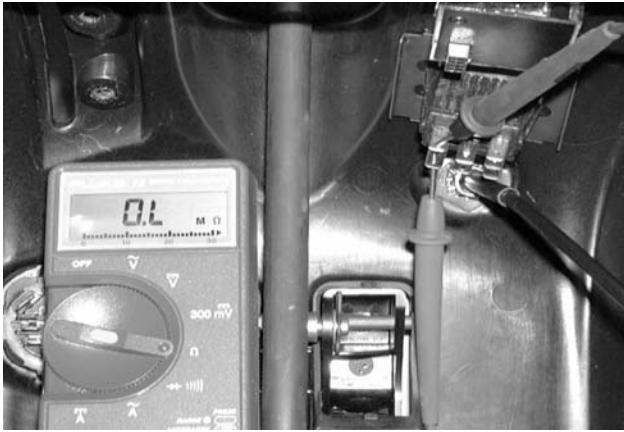


Figure 9-78

7. Push the PTO switch back to the OFF position and check the two right terminals...**OXX** in the middle.  
–There will be **NO CONTINUITY**. See Figure 9-79.

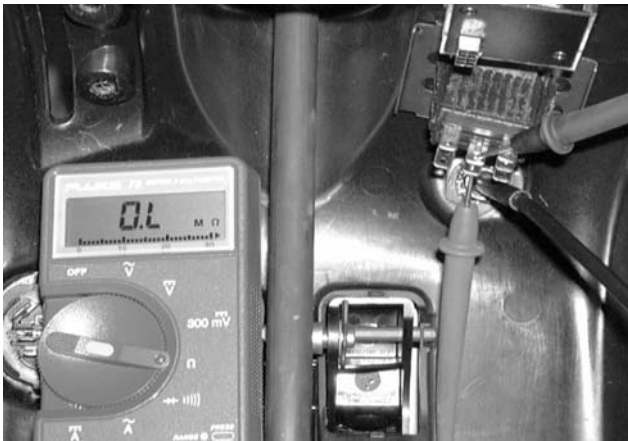


Figure 9-79

8. Pull the PTO switch to the ON position.  
–There will be **CONTINUITY**. See Figure 9-80.



Figure 9-80

9. Push the PTO switch back to the OFF position and check the outer two terminals in the last set of three...**XXX**.  
–There will be **CONTINUITY**. See Figure 9-81.



Figure 9-81

10. Pull the PTO switch to the ON position.  
–There will be **NO CONTINUITY**.
11. Push the PTO switch back to the OFF position and check the two right terminals for continuity...**XXX**.  
–There will be **NO CONTINUITY**.
12. Pull the PTO switch to the **ON** position.  
–There will be **CONTINUITY**. See Figure 9-82.



Figure 9-82

**➔ NOTE**

If any of the above tests do not match, the electric PTO switch is defective. Recheck the PTO switch to make certain that it is defective.



## IGNITION SWITCH

### ➔ NOTE

Remove all four self tapping screws securing the fuel tank to the dash panel using a 1/2" socket. Lower the fuel tank out of the way.

#### Terminal Codes:

G=Ground S=Start M=Magnet L=Lights  
B=Battery A1=Alternator A2=Alternator-Lights

### ➔ NOTE

A multimeter is a must for this section. If any of the following tests do not match, repair that portion of the system.

1. From behind the dash panel, locate the ignition switch and wiring harness connector. See Figure 9-83.

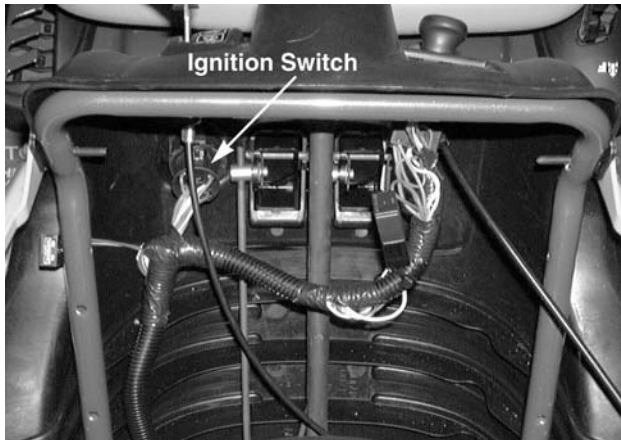


Figure 9-83

2. Remove the wiring harness connector from the ignition switch. See Figure 9-84.
3. Make certain the multimeter is working properly. Hold both test probes apart and check the meter display.  
–There will be an **O.L.** (open line) reading. See Figure 9-84.



Figure 9-84

4. Turn the key to the **ON** position. Place the test probes on the B and A1 terminals.  
–There will be **CONTINUITY**. See Figure 9-85.

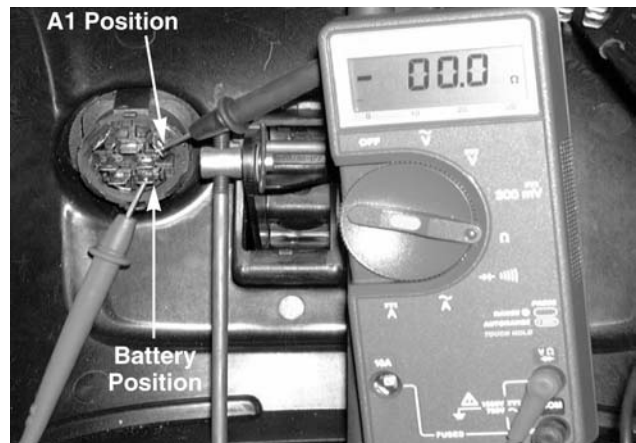


Figure 9-85

5. Turn the key to the **OFF** position.  
–There will be **NO CONTINUITY**.
6. Leave the key in the **OFF** position. Place the test probes on the M and G terminals.  
–There will be **CONTINUITY**. See Figure 9-86.





Figure 9-86

7. Turn the key to the **ON** position.  
–There will be **NO CONTINUITY**.
8. Leave the key in the **ON** position. Place the test probes on the B and S terminals.  
–There will be **NO CONTINUITY**.
9. Turn the key to the **START** (spring loaded) position.  
–There will be **CONTINUITY**. See Figure 9-87.

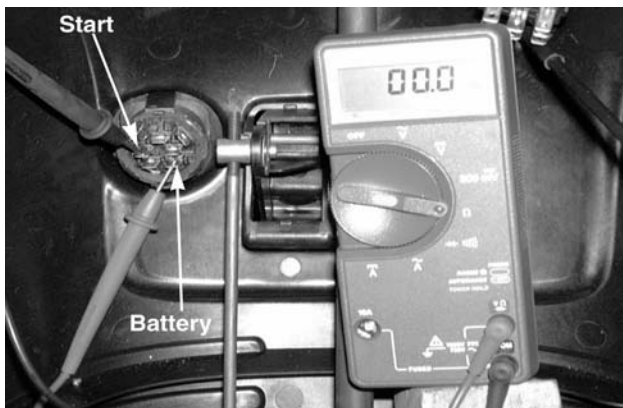


Figure 9-87

10. Leave the key in the **ON** position. Place the test probes on the B and A1 terminals.  
–There will be **CONTINUITY**. See Figure 9-88.

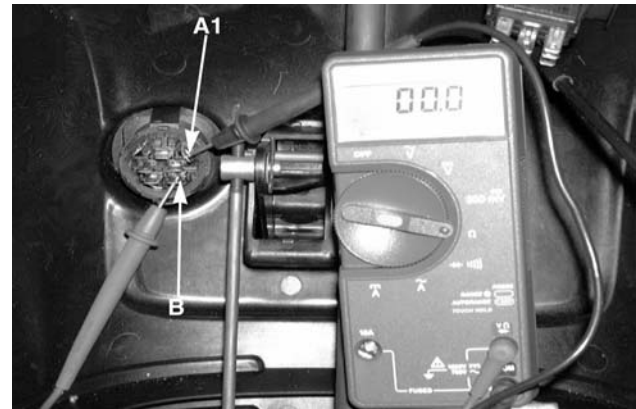


Figure 9-88

11. Turn the key to the (spring loaded) **START** position.  
–There will be **CONTINUITY**.
12. Turn the key to the **LIGHTS** position. Place the test probes on the L and A2 terminals.  
–There will be **CONTINUITY**. See Figure 9-89.

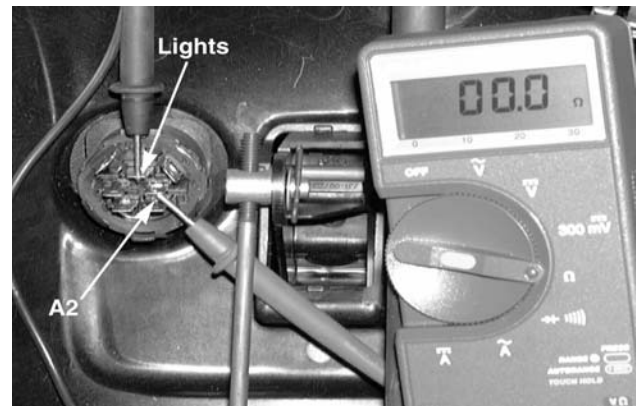


Figure 9-89

13. Turn the key to the **OFF** position.  
–There will be **NO CONTINUITY**.

**➡ NOTE**

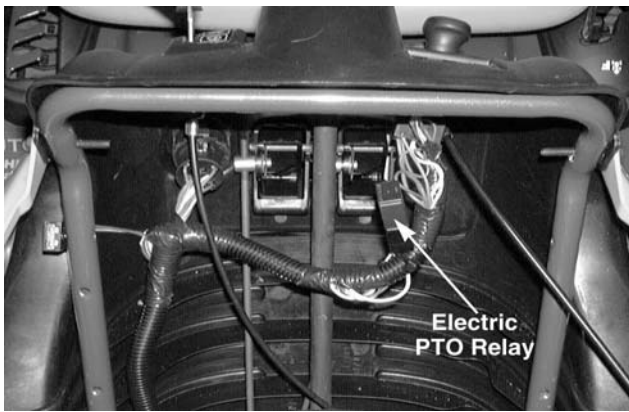
The ignition switch can be removed by depressing the upper and lower tabs.

**ELECTRIC PTO RELAY**

**➡ NOTE**

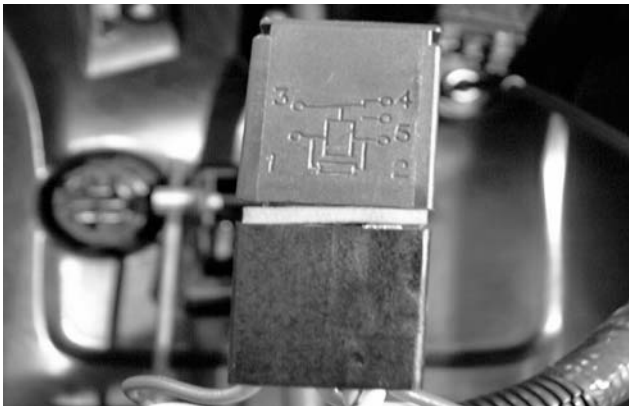
Remove all four self tapping screws securing the fuel tank to the dash panel using a 1/2" socket. Lower the fuel tank out of the way.

1. Locate the electric PTO relay and wiring harness. See Figure 9-90.



**Figure 9-90**

2. Remove the PTO relay from the wiring harness connector. See Figure 9-91.

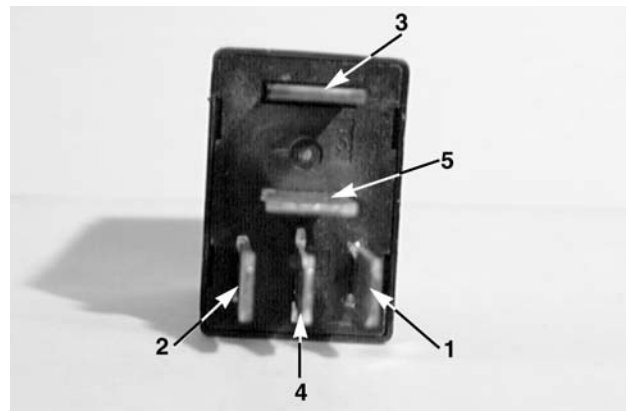


**Figure 9-91**

**NOTE**

The relay circuitry is on the front of the relay.

3. Place the relay on a flat surface and identify the corresponding male terminals. See Figure 9-92.



**Figure 9-92**

**NOTE**

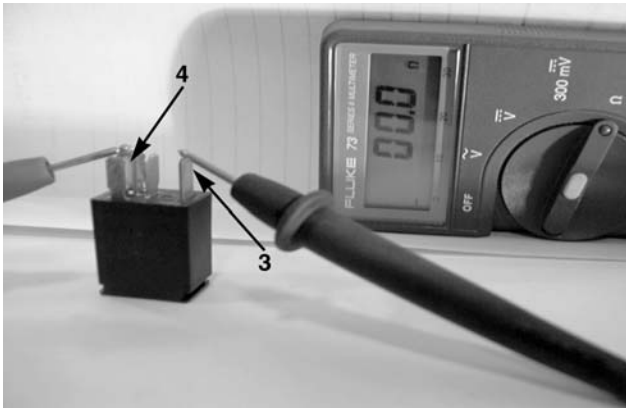
The male terminals are labeled at the base of the relay.

4. Using an ohm meter, place the test probes on terminals 1 and 2.
  - Depending on the temperature, the ohms reading should be approximately 82 ohms. See Figure 9-93.



**Figure 9-93**

5. Place the test probes on terminals 3 and 4.
  - There will be **CONTINUITY**. See Figure 9-94.



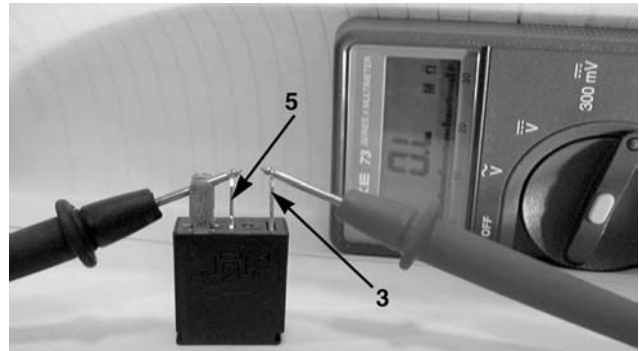
**Figure 9-94**

6. Locate a 12 volt battery and hook up a positive and negative jumper wire.
7. Place the positive jumper wire on terminal 1 and a negative jumper wire on terminal 2 of the relay. The relay will activate.  
–There will be **NO CONTINUITY** on terminals 3 and 4.
9. Leave the battery hooked up to terminals 1 and 2.

10. Place the test probes on terminals 3 and 5.  
–There will be **CONTINUITY**.
11. Remove the positive and negative jumper wires from the relay.  
–There will be **NO CONTINUITY** on terminals 3 and 5. See figure 9-95.

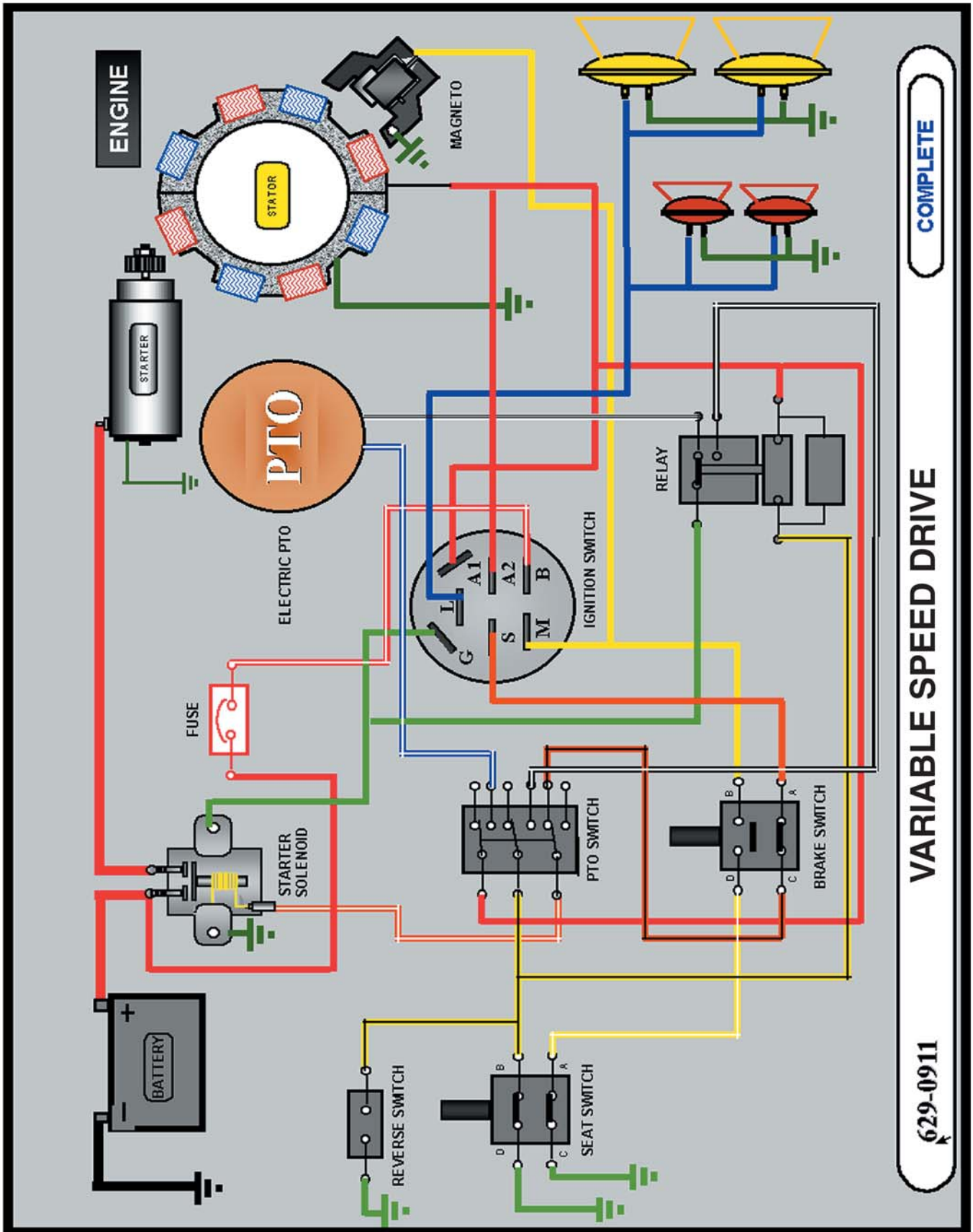
**➔ NOTE**

If any of the above tests do not match, the relay is defective. Recheck the relay to make certain that it is defective.



**Figure 9-95**

# Electrical Drawing



# AUTODRIVE/AUTOCRUISE

## REPORTS OF INSTANCES OF EXCESSIVE VIBRATION WHEN DECK IS ENGAGED

This pertains to models 600–619, with a manual engaged 42" deck, single cylinder engine, and a single deck/PTO drive belt. Procedures to reduce the vibration include inspecting the following components for wear, orientation, and damage: deck drive belts, belt keepers, pulleys, blades, spindles, deck brake rod and cable, deck hanger pins, stabilizer rod, and welded washers on the deck stabilizer bracket. If vibration persists, install rubber washers between the dash support tube and frame on both sides of the tractor. Refer to service kit 753-0886. See Figure 9-96.

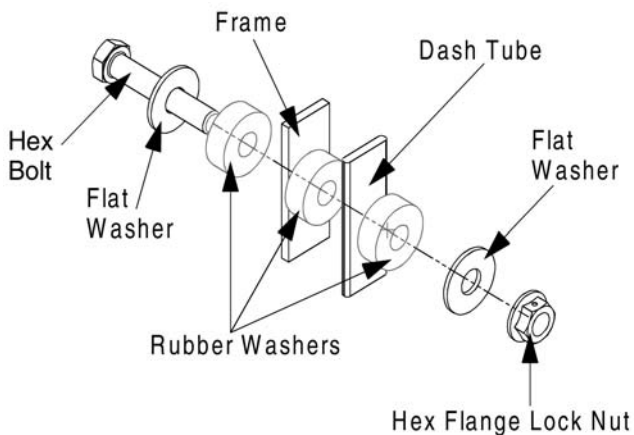


Figure 9-96

## REPORTS OF EXCESSIVE GRASS CLIPPING BLOW OUT WHEN MULCHING

This pertains to 42" decks produced since 1997. A two piece skirt will extend across the front deck lip. Refer to service kit 753-0884.

## REPORTS OF BROKEN SHIFT KNOBS

This pertains to shift knob 631-0009 used on 600 and 800 series riders. The material and design of the shift knob are being evaluated. Production and service will be using the smaller style shift knob 920-0232 used on the box frame units.

## A NEW SINGLE SPEED TRANSMISSION

Transmission 618-0551 replaces 618-0307D and will be used in 2001 600 series riders. The

new transmission will NOT have a reduction gear and chain. The clutch collar engagement pins have been replaced with a clutch dog style shift collar. The new style transmission will use 27 ounces of grease, part number 737-0148. See Figure 9-97.

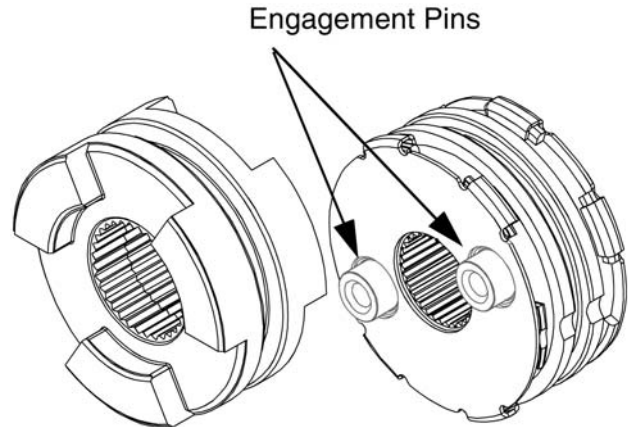


Figure 9-97

## REPORTS OF TIRE CHAINS RUBBING SHIFT LEVER

This pertains to models 604-609 with 20 x 10 x 8 rear tires. Replace the wheel assemblies with the 20 x 8 x 8 wheel assemblies, part number 634-0104-09XX (where X represents the tire and paint code). Do not replace the tires alone as the diameters between the 20 x 10 and 20 x 8 tires are not the same. Have the customer retain the 20 x 10 wheel assemblies for use with the mower deck installed. Replace tire chains OEM-190-915 with tire chains OEM-190-658.

## ENHANCE BAGGING PERFORMANCE

Two in one high lift blades, part number 742-0656, are now available for all 42" decks. The high lift blades will enhance bagging performance.

## TRANSMISSION PULLEY TORQUE AND BELL WASHER

This pertains to 600 series riders. The hex nut securing the transmission pulley to the input shaft should be torqued from 10-15 foot pounds. Only one bell washer will be installed between the hex nut and transmission pulley. See Figure 9-98.

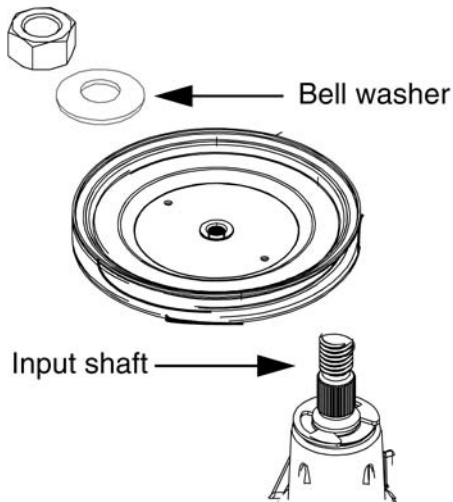


Figure 9-98

**COMPLETE DECK REPLACEMENTS WILL INCLUDE SPINDLES WITH A FITTING TO GREASE THE SPIN-DLE SHAFT**

For 600 series riders this includes: manual PTO 42" decks 753-0871, (683-0198D for single cylinder models), electric PTO 42" decks 753-0873, manual PTO 46" decks 753-0872, and electric PTO 46" decks 753-0874. For 800 series tractors this includes: electric PTO 46" decks 753-0875 and electric PTO 50" decks 753-0877. Include color code when ordering decks.

**REPLACEMENT SPINDLES WITH A FITTING TO GREASE THE SHAFT ARE AVAILABLE**

This includes spindle 918-0427A for 42" decks, (918-0574 for single cylinder models), spindles 918-0430 (center) and 918-0431 (left/right) for 46" decks, and spindles 918-0428A (center) and 918-0429 (left/right) for 50" decks. Replacement spindles without grease fittings are still available.

**REPORTS THAT CENTER SPINDLE PULLEY ON 50" DECKS MAY HIT THE PTO IDLER BRACKET ASSEMBLY**

This prevents the deck lift handle from reaching the highest cutting positions. A third set of holes has been added to the deck stop. The deck stop should be mounted to the right hand frame assembly using the top set of holes with 46" decks, the center set of holes with 50" decks, and the bottom set of holes with 42" decks. Also, drill a hole in each lift arm approximately 1/4" above original mounting hole for the lift cable. Reinstall the lift cables in the higher hole. Refer to service bulletin T-154.

**REPORTS THAT CENTER SPINDLE PULLEY ON 46" DECKS MAY HIT THE PTO IDLER BRACKET ASSEMBLY**

This pertains to 600 series riders with manual engaged 46" decks. The deck stop bracket should be mounted to the frame using the top set of holes. Only two spacers are installed above the PTO engagement plate, 738-0372 and 748-0415A. Spacer 711-0242 is installed between these two spacers on manual engaged 42" decks and is not in the illustrated parts list. See Figure 9-99.

**POSSIBLE PREMATURE WEAR OF THE PTO BELT**

This pertains to manual engaged 42" and 46" decks. An incorrect belt guard, 732-0990, is shown in the illustrated parts. The correct belt keeper is 732-1013. The position of the belt keeper shown in the illustrated parts is incorrect. The belt keeper should be installed beneath the PTO engagement plate with the tab bent up, not down. Incorrect assembly of the belt keeper could cause the keepers to shift on the plate and rub the belt. See Figure 9-99.

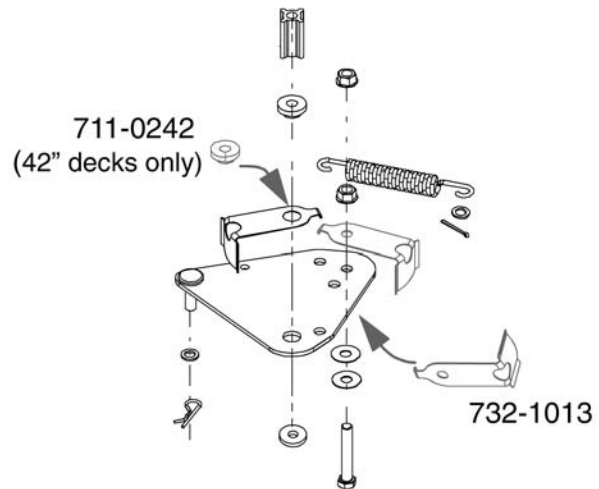


Figure 9-99

**GRILL CHANGES**

This pertains to model 609, 9-style grills. We have received reports of grills cracking at the lower mounts and also where the upper and lower tabs secure the side panels and hood.

Once the tabs crack, the screws back out of the "U" type speed nut and the assembly detaches. The "U" type speed nuts have been replaced by a metal grill reinforcement bracket. The reinforcement bracket will be mounted to

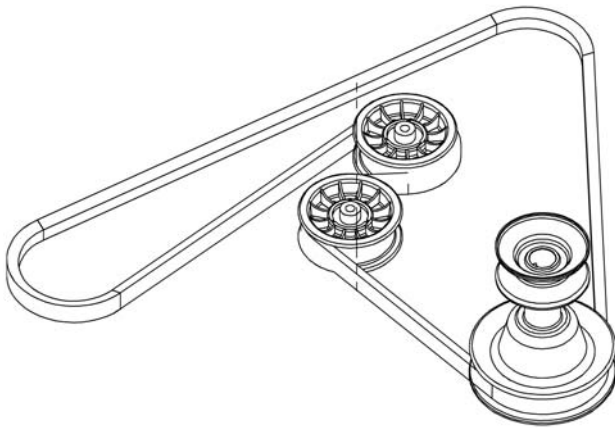
the side panels with screws, and to the hood hinge rod and grill with two screws and washers. The material used to produce the grills has also been upgraded. Replacement 9-style grills will now come with reflectors.

#### **REPORTS OF PREMATURE PTO DRIVE BELT FAILURES**

This pertains to 600 series models equipped with manual engaged 46" decks and a PTO belt with a Gates serial number of 170SS and prior. Replace the belt with a belt that has a Gates serial number of 170SS or higher.

#### **PREMATURE WEAR OF THE FLAT PLASTIC PTO ENGAGEMENT IDLERS**

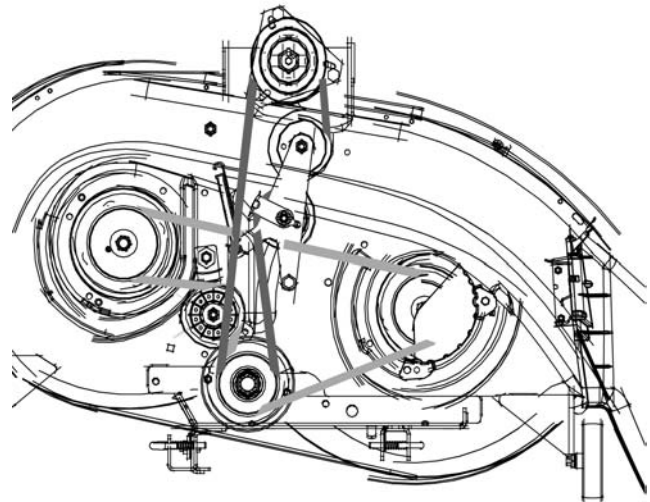
This pertains to 600 and 800 series riders with manual engaged 42" and 46" decks. The flat idler pulleys, part number 756-0627B, are changing from plastic to metal. See Figure 9-100.



**Figure 9-100**

#### **NEW FOR 2001 - 42" DECK**

The deck assembly will use two belts instead of one. A PTO drive belt will run from the engine pulley, around an idler pulley, and to a double pulley mounted at the center of the deck. A spindle drive belt will run from the double pulley to the left and right spindle pulleys. The addition of the stack pulley reduces the angle of the belt running from the engine pulley by 50 percent when the deck is in the lowest cutting position. See Figure 9-101.



**Figure 9-101**

#### **REPORTS OF EXCESSIVE GRASS CLIPPING BLOW OUT WHILE MULCHING**

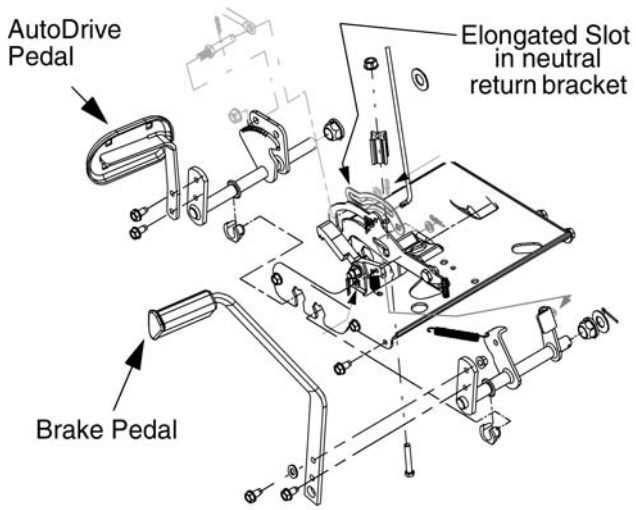
A new 38" and 42" mulch kit, OEM-190-116, will replace mulch kit OEM-190-112. It contains the following: a redesigned mulch plug, deck skirts and mounting hardware for both 38" and 42" decks, and a template for drilling the holes to install the skirts and plug. For 2001, the skirts will be mounted on production riders specified to include the mulch plug. Models that do NOT include the plug at the factory will NOT come with the skirts installed on the deck. Holes will have to be drilled to mount the skirts on all 38" and 42" decks produced prior to 2001. Units produced for 2001 will have the new mulch plug mounting holes and deck skirt holes drilled at the factory. The new plug improves mulching, decreases grass build up beneath the deck, and is easier to install.

#### **ELONGATED SLOT IN NEUTRAL RETURN BRACKET**

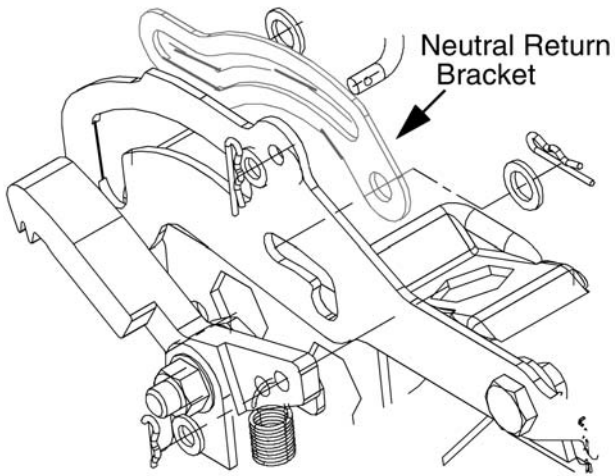
This pertains to autodrive/autocruise units produced prior to the year 2000. The slot in the neutral return bracket, 783-0780, has been elongated. See Figures 9-102 and 9-103.



Some illustrated parts incorrectly show the neutral return bracket twice. See Figure 9-103.



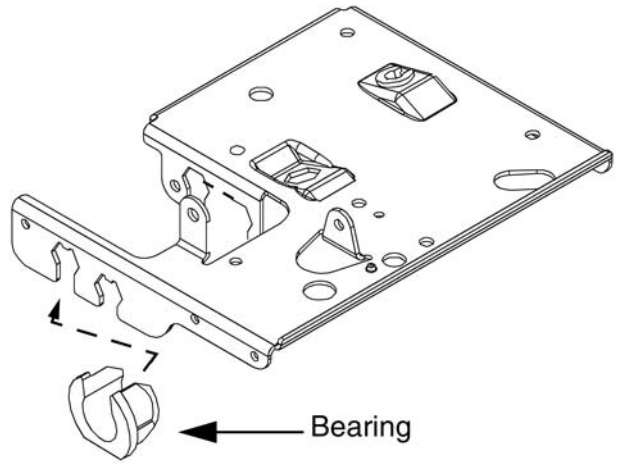
**Figure 9-102**



**Figure 9-103**

**STEERING SUPPORT BRACKET**

This pertains to 600 and 800 series units. A bent support bracket can crack the bearing, 741-3065A, and cause the speed control pedal to bind. See Figure 9-104.



**Figure 9-104**





# MTD Z SERIES TRANSMISSION—THEORY OF OPERATION

The speed and the direction of the tractor are controlled by two independently operated hydrostatic transaxles that direct power to each drive wheel.

The engine drives each hydrostatic pump using a belt and pulley system.

There is a constant and equal input provided to each pump relative to the rpm of the engine. The engine should be run at full throttle during normal operation.

During operation the input pulley turns the hydro input shaft.

The hydrostatic pump is a variable displacement fluid pump with two sections. The constant input can be changed in speed and direction by varying the angle of an internal swash plate that drives the pump pistons and affects the output of the pump motor. This angle is controlled by the position of the hydrostatic control arm. As the angle increases more fluid is supplied to the pump motor and the faster the pump motor turns. Infinitely variable speeds from stop to full power are available. This is true in both forward and reverse.

The output shaft of the hydrostatic transmission drives the input of the transmission using a pinion gear.

The pinion gear drives an Internal reduction gear assembly.

A stationary ring gear is held in place by the transmission housing.

The sun gear on the reduction gear assembly drives the planetary gears attached to the gear carrier. This gear carrier is splined to the axle shaft.

As the sun gear turns the planetary gears against the stationary ring gear the carrier turns the axle shaft.

This provides a compact means to reduce the speed of the axle shaft.

The speed of each axle is controlled by the output speed of the Hydrostatic pump. This is how turning and braking of the tractor is controlled.

Each axle can be independently operated in forward, neutral, or reverse and at variable speeds. This provides a high degree of maneuverability and the ability to mow around small obstacles.

In an extreme case one axle can be moving forward while the other is moving in reverse. This would turn the unit on its' exact center and provide a way to turn the unit in a very confined space.

Each transaxle has an internal parking brake. This brake can also be used to stop the unit if necessary.

## Z SERIES NEUTRAL/STEERING ADJUSTMENT

1. Park the unit on flat, level ground.
2. Remove the ignition key.
3. Pull outward and detach the base of the control bellow from the bellow retaining bracket.
4. Slide the control bellow upward (towards the drive control handles. See Figure 10-1.

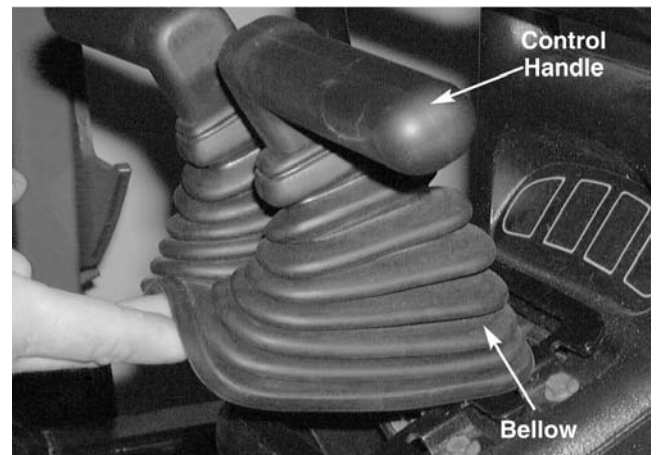


Figure 10-1.

- Remove the carriage bolt and flange lock nut securing each drive control handle to the upper left and right bellcrank assemblies using a 1/2" socket. See Figure 10-2.

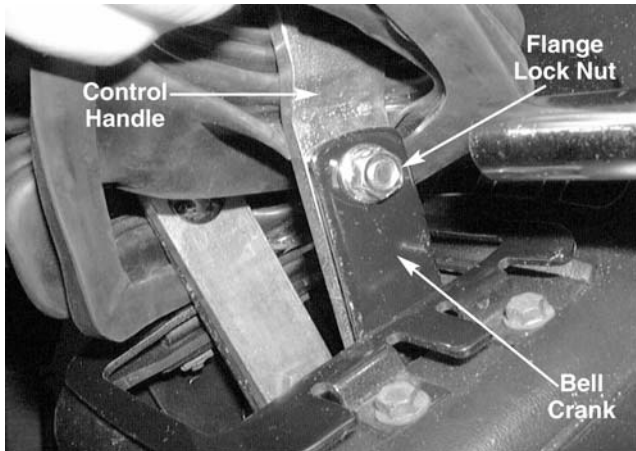


Figure 10-2.

- Remove both of the drive control handles and the control bellow, and set them aside.
- Remove all four hex washer head screws securing the bellow retainer bracket to the top of the support tower using a 3/8 socket. See Figure 10-3.

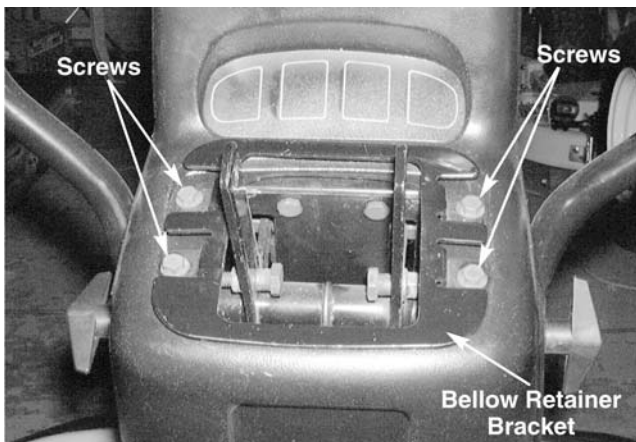


Figure 10-3.

- Pull straight up on the console assembly and remove it from the rider.
- Remove both safety switches from the irrelative holders by squeezing the retaining clips in and pushing upward until they are clear of the securing brackets. See Figure 10-4.

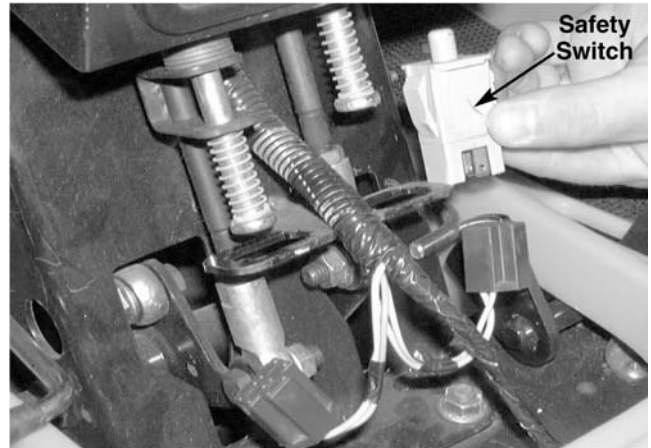


Figure 10-4.

**NOTE**

Pivot both upper bellcrank assemblies rearward to allow full clearance between the safety switches and the push pins.

- Remove the hex cap screw and flange lock nut securing each control rod assembly to the upper left and right bellcrank assemblies using a 9/16 socket and 9/16 wrench. See Figure 10-5.

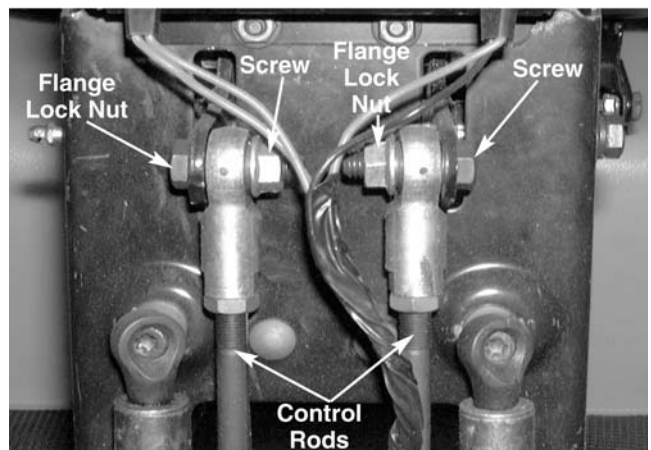


Figure 10-5.

**NOTE**

The damper cylinders will remain secured to the support tower assembly.

- Remove the hex cap screw and flange lock nut securing each control rod assembly to the lower left and right bellcrank assemblies using a 9/16 socket and a 9/16 wrench. See Figure 10-6.

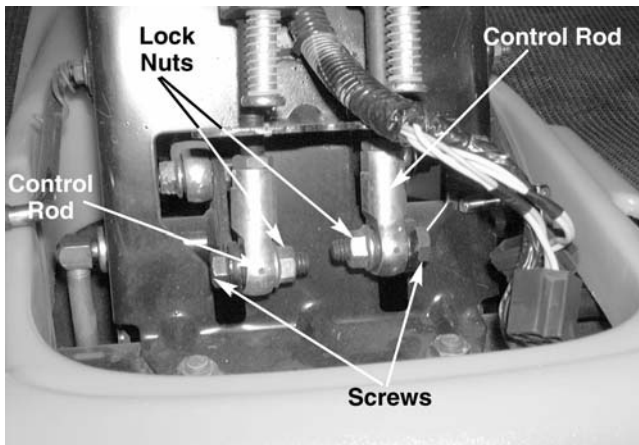


Figure 10-6.

**NOTE**

The damper cylinders will remain secured to the control rod assemblies.

12. Raise the seat.
13. Disconnect the wiring harness connector from the seat switch and push it down through the seat platform.
14. Remove all four hex bolts securing the seat platform to the upper frame rails using a 9/16 socket. See Figure 10-7.

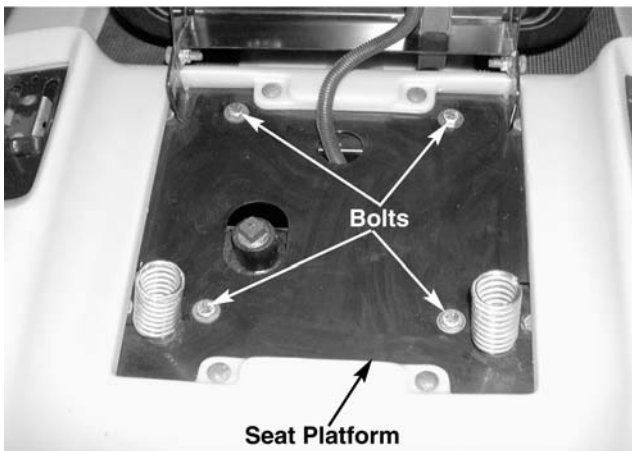


Figure 10-7.

15. Remove the rear fender assembly and set it aside.

16. Remove all four hex bolts securing the rear of the foot board body to the center frame rails using a 1/2" socket. See Figure 10-8.

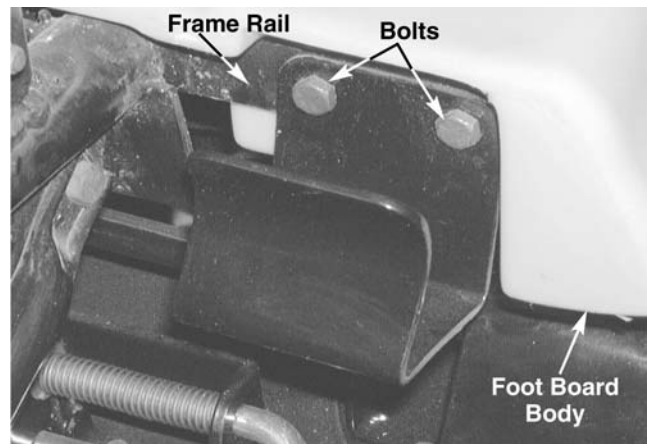


Figure 10-8.

17. Remove both front shoulder bolts securing the front of the foot board body to the front frame assembly using a 15/16 socket. See Figure 10-9.

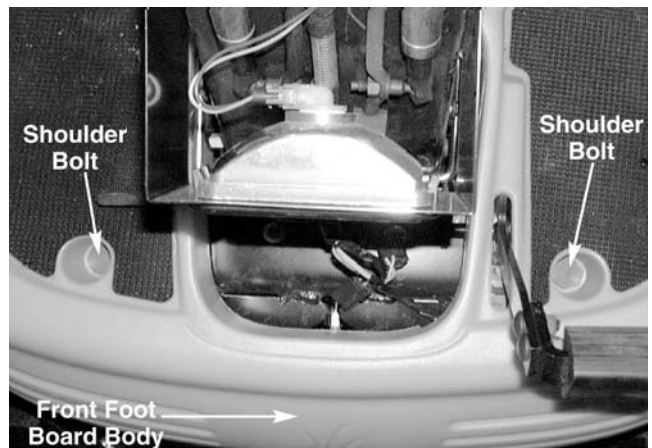


Figure 10-9.

18. Remove the hex flange lock nut and carriage bolt securing the parking brake retaining rod bracket to the support tower assembly using a 7/16 socket. See Figure 10-10.

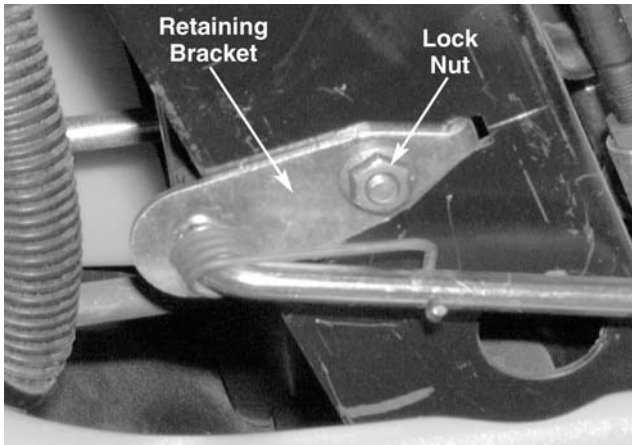


Figure 10-10.



This is the set position for neutral.

19. Remove both hex flange lock nuts and carriage bolts securing the brake pedal to the brake arm assembly using a 9/16 socket. See Figure 10-11.



Figure 10-11.

20. Insert a 1/4" by 7" dowel pin or equivalent through the upper alignment hole of the support tower, through the upper left and right bellcrank assemblies, and out the opposite side of the support tower. See Figure 10-12.

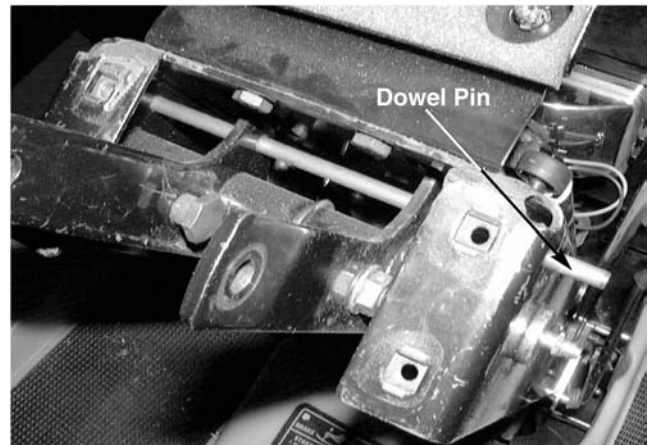


Figure 10-12.

21. Raise the front of the foot board body high enough to insert a 1/4" by 7" dowel pin or equivalent through the lower alignment hole of the support tower, through the lower left and right bellcrank assemblies, and out the opposite side of the support tower. See Figure 10-13.

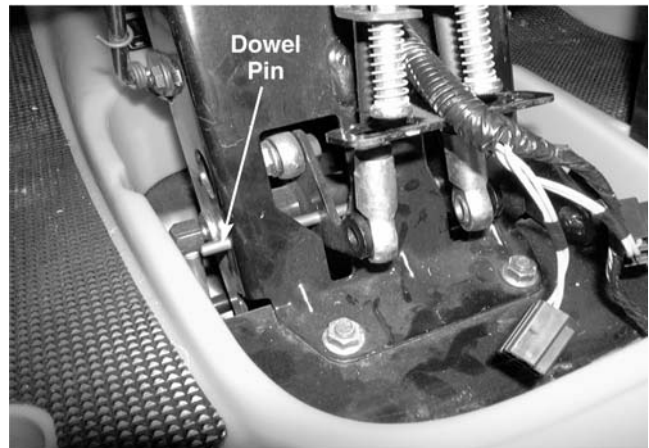


Figure 10-13.



This is the set position for neutral.

22. With the damper cylinders secured, loosen all four hex jam nuts that maintain the alignaball positions on the control rod assemblies using a 9/16 wrench. See Figure 10-14.

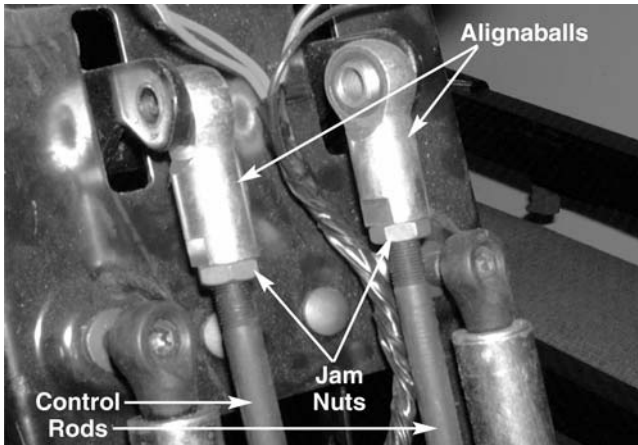


Figure 10-14.

23. With the damper cylinders secured, adjust all four alignaballs until the hex cap screws (removed earlier) slip into the upper and lower bellcrank assemblies with little effort.
24. Secure the alignaballs and hex cap screws to the bellcrank assemblies with the flange lock nuts removed earlier using a 9/16 socket and a 9/16 wrench. See Figure 10-15.

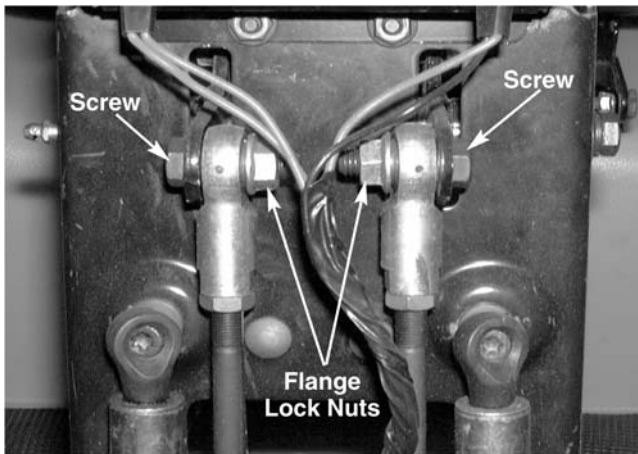


Figure 10-15.

25. Tighten all four hex jam nuts that maintain all the alignaball positions on the control rod assemblies using two 9/16 wrenches.
26. Raise the rear of the rider until the rear wheel assemblies are off the ground, and secure it with jack stands. See Figure 10-16.



Figure 10-16.

27. Locate the hydrostatic control rods that run from the lower bellcrank assemblies to the hydrostatics. See Figure 10-17.

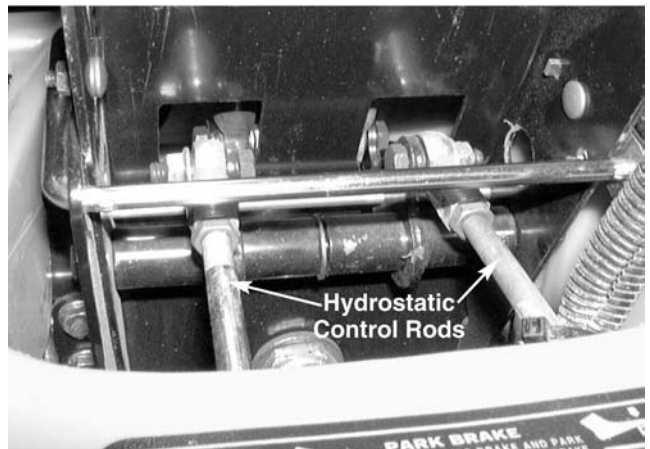


Figure 10-17.

28. Loosen all four hex jam nuts that maintain the alignaball positions on the hydrostatic control rods using two 9/16 wrenches. See Figure 10-18.

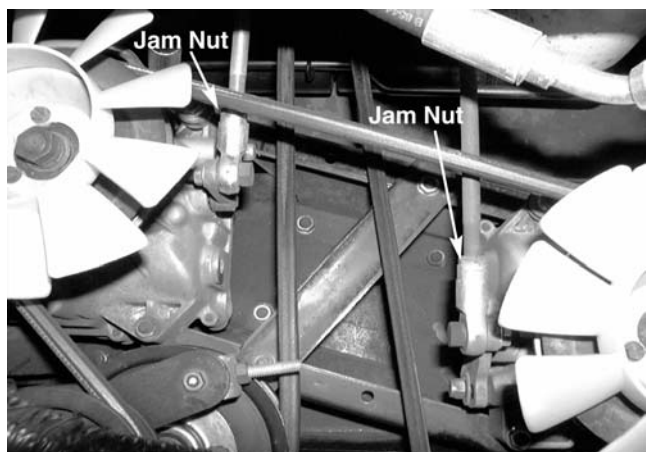
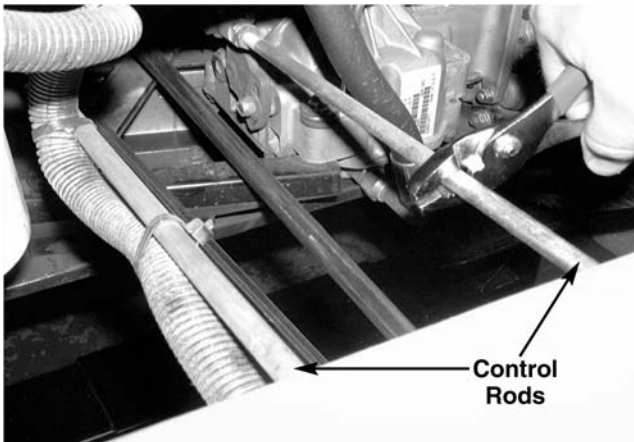


Figure 10-18.

29. Make certain the PTO is in the OFF position.
30. Depress the brake pedal, start the rider, and adjust the throttle to full.
31. Release the brake.
32. Rotate the hydrostatic control rods clockwise or counter-clockwise until the rear wheel assemblies come to a complete stop. See Figure 10-19.



**Figure 10-19.**

**➔ NOTE**

The rotation of the hydrostatic control rod will increase or decrease the length between the alignaballs on each hydrostatic control rod. The pump end is left handed, and the tower end is right handed.

33. Tighten all four hex jam nuts that maintain all the alignaball positions on the hydrostatic control rods using a 9/16 wrench. See Figures 10-17 and 10-18.

**➔ NOTE**

Make certain the hydrostatic control rods do not rotate while securing the jam nuts.

34. Shut the rider off and remove the 1/4" by 7" dowel pins from the upper and lower alignment holes in the support tower.
35. Depress the brake pedal, start the rider, and adjust the throttle to full.
36. Release the brake pedal and check the rear wheel assemblies for motion.

**➔ NOTE**

If there is motion, insert the 1/4" by 7" dowel pin and repeat steps 27 through 35.

37. If a state of no motion has been achieved, shut the rider off.
38. Raise the rear of the rider and remove the jack stands.
39. Lower the rear of the rider to the ground.

**REASSEMBLE THE RIDER IN THE REVERSE ORDER ABOVE.**

**NOTES**

---

---

---

---

---

---

---

---

---

---

---

---

---

---

---

---

---

---

---

---

---

---

---

---



# REMOVAL OF THE ZTT TRANSMISSION FROM THE TRACTOR

This section will show you how to remove the two hydrostatic transaxles from the ZTT tractor. We will also show you how to disassemble, inspect, and reassemble the gearbox. Finally we will show you how to adjust the neutral position for each transaxle to assure proper steering.

Although you may be working on only one of the transaxles, the easiest method of repair is to remove both transaxles at the same time, leaving them attached to the lower side pan.

Before beginning, disconnect the negative cable from the negative terminal on the battery. See Figure 10-20. This will assure that no current can flow through the electrical system.

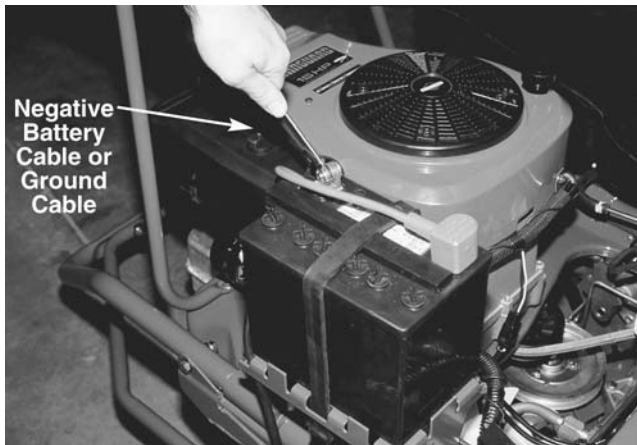


Figure 10-20.

Using a jack and blocks of wood, jack the unit up using the rear bumper for jack placement. See Figure 10-21.



Figure 10-21.

Remove both wheels to allow easy access to the remainder of the components.



Figure 10-22.

Place wooden blocks under the skid pan and lower the unit onto the blocks while at the same time keeping some of the weight on the bumper jack. See Figure 10-23.

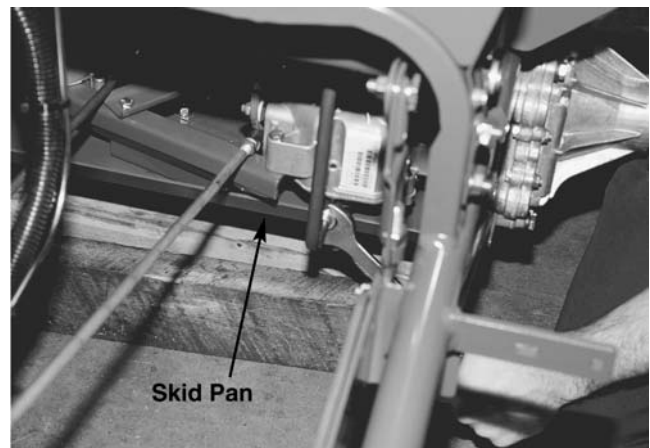
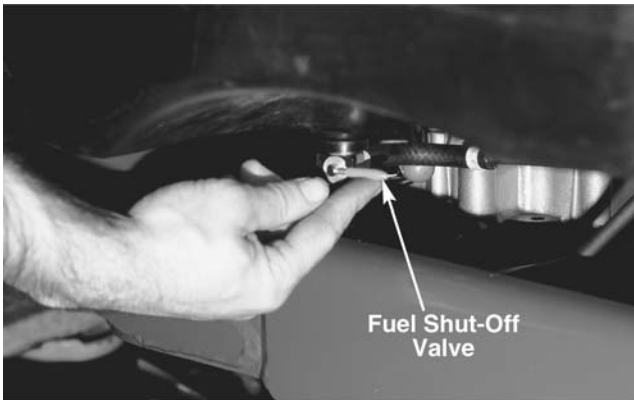


Figure 10-23.

Turn the fuel valve to the off position. It is located below the fuel tank. See Figure 10-24.



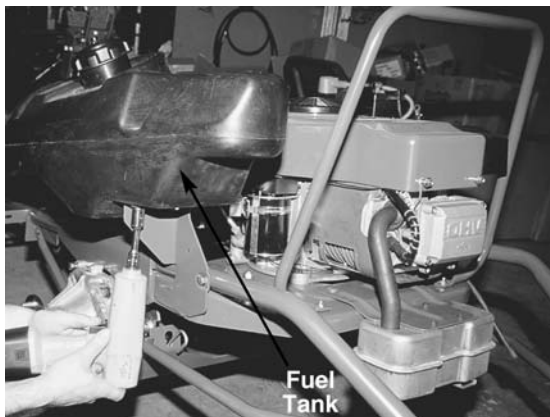
**Figure 10-24.**

Place a rag below the fuel line to catch any spilled fuel and disconnect the fuel line.

Using a 9/16 socket, remove the four bolts attaching the fuel tank to the mounting brackets.

Remove the fuel tank from the tractor and set it aside. See Figure 10-25.

Set the parking brake to relieve tension on the idler pulley to ease removal of the drive belt.



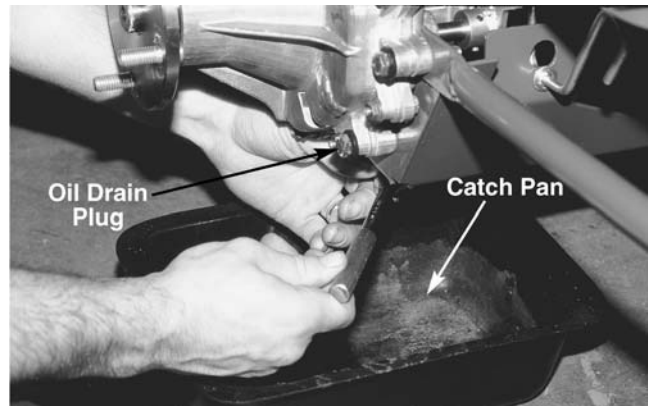
**Figure 10-25.**

Remove the belt from the drive pulleys. See Figure 10-26.



**Figure 10-26.**

Place a catch pan under the transmission, remove the drain plug, and drain all of the oil from transmission. See Figure 10-27. Do this for both transmissions. This procedure will also drain the oil from the oil reservoir. Total oil loss approximately three gallons.



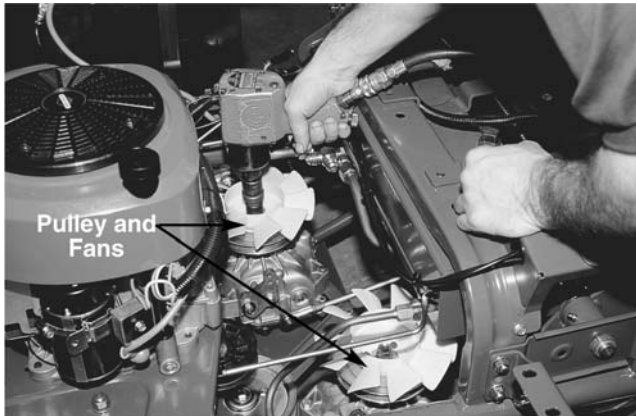
**Figure 10-27.**

Disconnect the four hydraulic lines where they connect to the oil reservoir. See Figure 10-28.



**Figure 10-28.**

Remove the cooling fan and pulley from each hydraulic pump. This will allow easy access to the remaining parts and ease removal of the pumps from the tractor. See Figure 10-29.



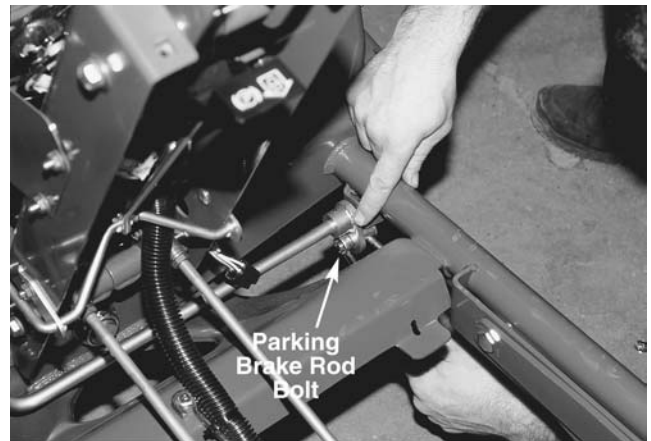
**Figure 10-29.**

Remove the control arm bolts where they connect to the hydrostatic pumps and lower each arm out of the way. See Figure 10-30.



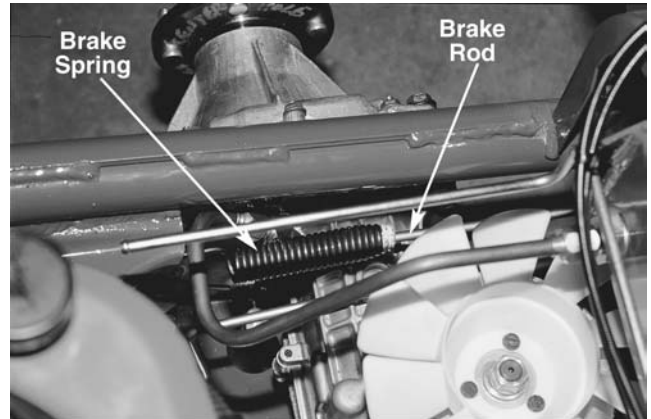
**Figure 10-30.**

Remove both parking brake rods from near the front of the tractor by unbolting them and separating them from the bracket. See Figure 10-31.



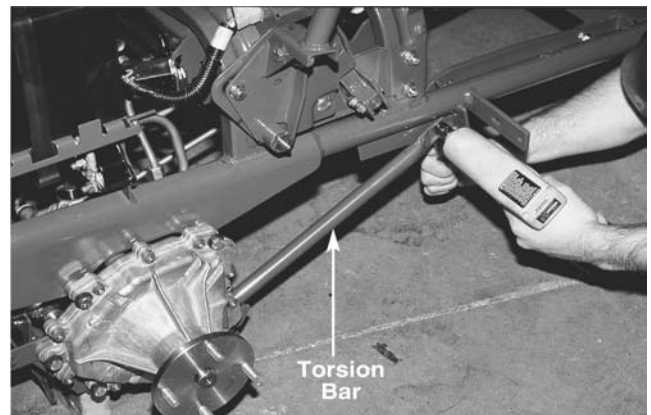
**Figure 10-31.**

Remove the threaded adjustment ferrules from each rod and slide the rods to the rear of the tractor, removing them from the back of the unit. See Figure 10-32.



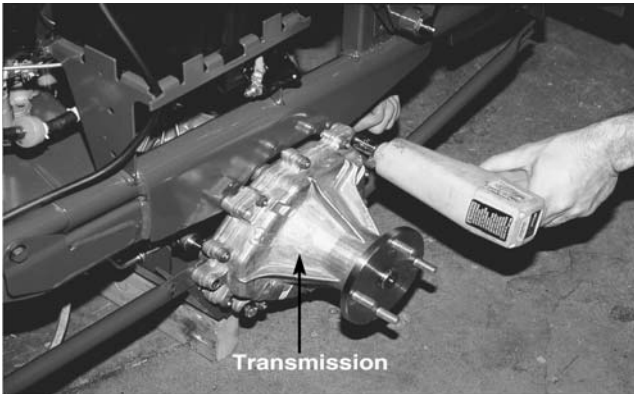
**Figure 10-32.**

Remove both torsion bars supporting the front of the transmission to the frame. See Figure 10-33.



**Figure 10-33.**

Remove the bolts attaching the transmission to the frame. See Figure 10-34. Do this for both transmissions. The blocks of wood under the pan should support the pan and keep it from dropping as you remove the bolts.



**Figure 10-34.**

Jack the unit up to raise the frame above the transmissions.



**Figure 10-35.**

Loosen the lower bumper, see Figure 10-36 and strap it up out of the way to ease removal of the transaxle skid pan.

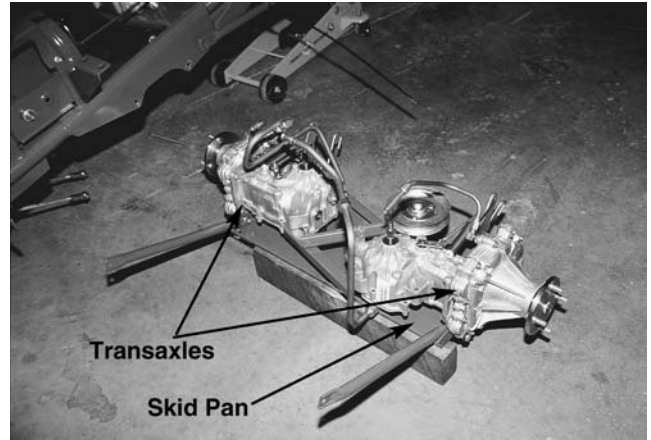


**Figure 10-36.**

Remove the transaxle from the skid pan and place it on your work bench.

Slide the transaxle assembly from under the tractor.

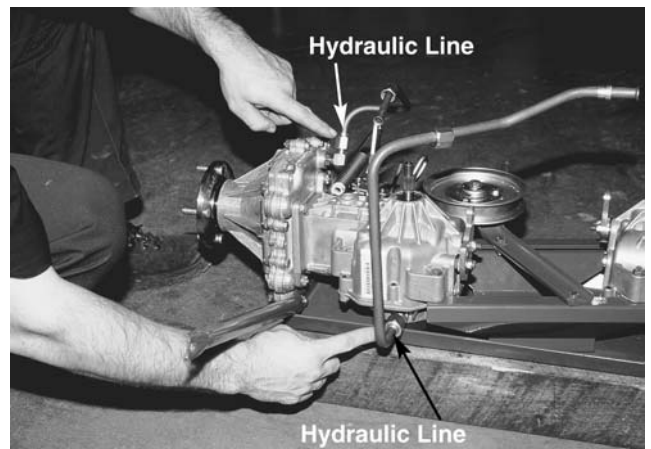
If you are only repairing one transmission, follow the remaining steps to remove only the transmission you will be working on.



**Figure 10-37.**

Follow the same procedures to remove the other transaxle from the skid plate.

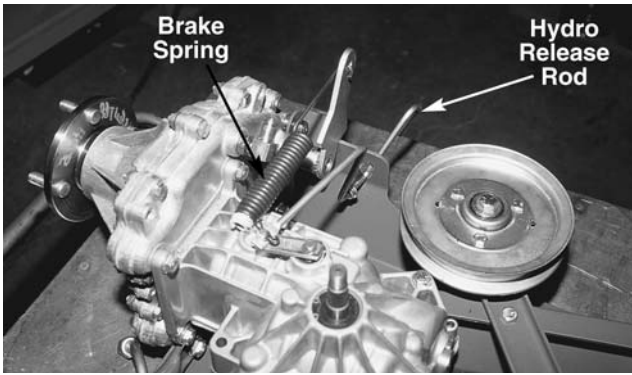
Remove the hydraulic lines from the transaxle.



**Figure 10-38.**

Remove the brake spring. See Figure 10-39.

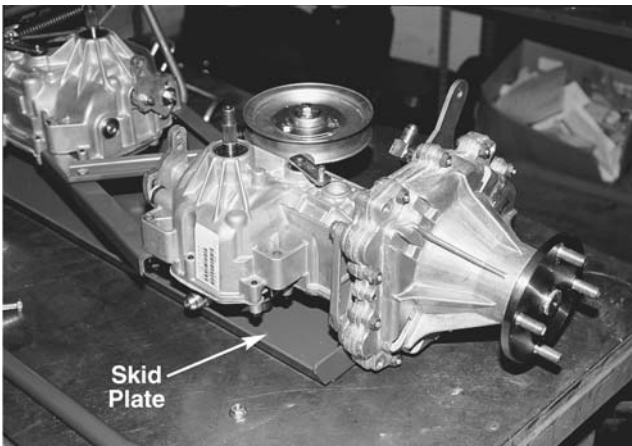
Remove the hydro release rod by disconnecting the hairpin and setting the rod aside. See Figure 10-39.



**Figure 10-39.**

Remove the two hydrostatic transmission support bolts.

Then remove the transmission support bolts.



**Figure 10-40.**

Remove the transaxle from the skid pan and place it on your work bench.

Follow the same procedures to remove the other transaxle from the skid plate.

This completes removal of the transmissions from the tractor.

### **REINSTALLING THE TRANSAXLES**

To ease reassembly, place the skid pan on a workbench.

We will start by installing the right side transaxle first by placing the transaxle onto the skid pan.

Next install the 5/16 inch hydro pump bolts. Do not tighten until after you have installed the 3/8 inch transmission bolts.

Attach the front support strut to the skid plate and transmission with a 3/8 inch bolt.

Use the remaining two bolts to attach the transaxle to the frame.

Tighten all bolts holding the transaxle to the skid pan.

Attach the hydro release rod to the transaxle with the hairpin.

Install the top hydraulic fluid line first, followed by the lower line. Graphic "REVERSE ANGLE"

Finally, attach the parking brake tension spring.

Install the left side transmission in a similar fashion.

Attach the hydro bolts.

Attaching the front support strut and remaining transmission bolts.

Tighten all bolts.

Attach the hydro release rod.

Followed by the parking brake spring.

Then attach both hydraulic lines.

Using a helper, place the assembled transmissions and skid on wooden support blocks and slide the assembly into place under the tractor. Align the pan with the tractor frame and place the control rods onto the pan for later assembly.

Lower the frame onto the transmission assembly and align the mounting bolt holes.

Make sure that the hydro lines are clear and install the mounting bolts.

Attach the front support bars on both sides of the unit.

Remove the rear mounting bolt, and attach the lower bumper tube.

Repeat this procedure for the other side.

Tighten all bolts attaching the transaxle and skid plate to the tractor frame. Torque all bolts to proper specifications.

Install the right hand hydraulic line. Hand tighten each pair of fittings.

Before installing the remaining lines, install both hydraulic pulleys. Then torque to spec.

Once you have finished installing the pulleys you can finish installing the hydraulic lines. Torque all fittings to spec. The lower fitting on the right hydro pump is hard to get to. We are showing this being done with a crows foot wrench.

Next we will install the parking brake rods. Slide the rod through the tension spring, through the holes in the frame brackets and forward to the parking brake bracket.

Install the ferrules on each brake rod, shorten or lengthen to line up with the brake lever. Bolt the ferrule to the brake lever.

Before connecting the control rods, check that the hydro control lever is straight up in a vertical position. This is a rough estimate for the neutral position.

You can then proceed to connect the two control rods. Attach the control rod by loosening the jam nut and adjusting the ferrule until it lines up with the hydro control lever. Insert the

retaining bolt and secure with the self locking flange nut. Finally, tighten the jam nut. Do this for each transaxle.

Install the drive belt by placing it over the engine pulley, slipping it over the hydro cooling fans and around the pulleys. When you release the parking brake the idler pulley should engage the drive belt.

Place the fuel tank over the two mounting brackets. Fasten with the four mounting bolts. Make sure you are using the proper bolts. Using bolts that are longer than the originals can strip the threads or puncture the fuel tank. Connect the fuel tank hose to the fuel line and secure with a hose clamp.

Install both wheels and torque to specifications.

Lower the unit to the ground and remove the jack. Tighten the lower rear bumper support where it connects to the main bumper. Attach the negative battery cable to the negative terminal, tighten, protect the terminal with the rubber cover.

Perform a neutral test to make sure the unit remains in neutral when stopped and does not creep or turn in either direction.

## TRANSMISSION DISASSEMBLY

1. REMOVE TRANSMISSION FROM TRACTOR. See Figure 10-41.

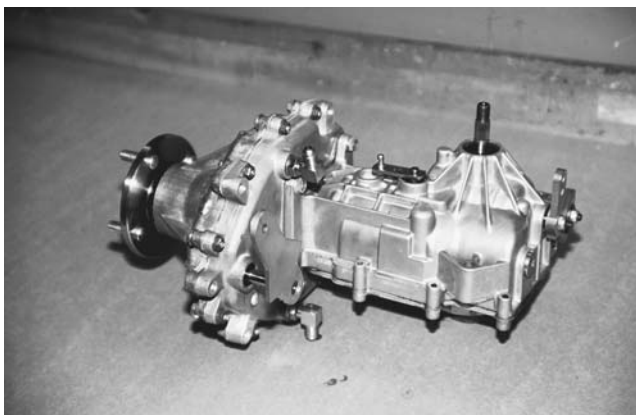


Figure 10-41.

2. Using an 11/16 wrench, remove the hydraulic fittings. This will allow easy removal of the nuts attaching the hydrostatic pump. See Figure 10-42.

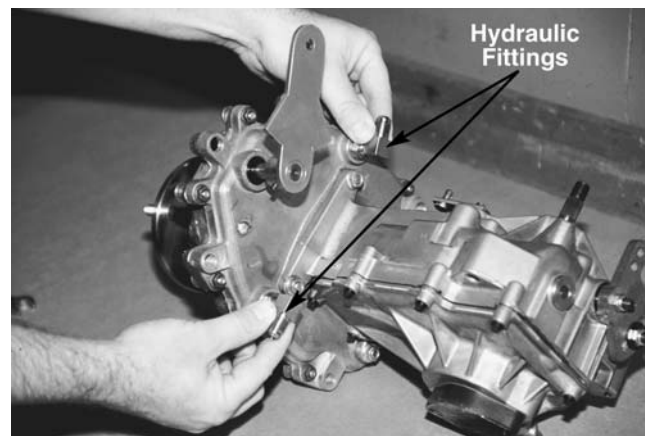


Figure 10-42.

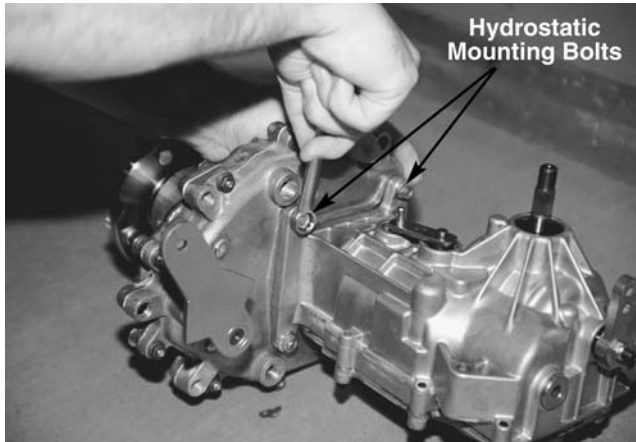
### ➡ NOTE

The fittings have "O" ring seals up against the washer. It is important not to damage it during removal. Also notice that the housing has a machined surface to accommodate the "O" ring



that should not be scratched or damaged during disassembly. This assures a good mating surfaced between the “O” ring and housing.

3. Separate the hydrostatic pump from the housing by using a 9/16 wrench and removing the four nuts securing the pump. See Figure 10-43.



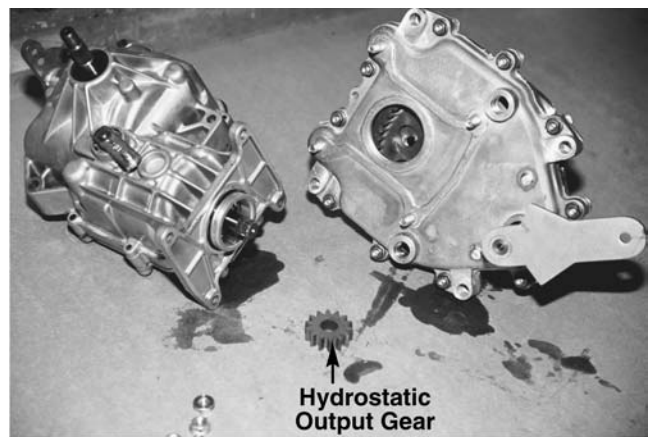
**Figure 10-43**

4. While separating the pump from the housing notice that the input pinion gear slides easily on and off the shaft. Make sure that the gear does not fall into the transmission housing during removal. Also notice that the four studs that stick out of the housing are pressed into the housing. When you remove the pump, do not jar these studs or allow them to fall into the housing. See Figure 10-44.

**➡ NOTE**

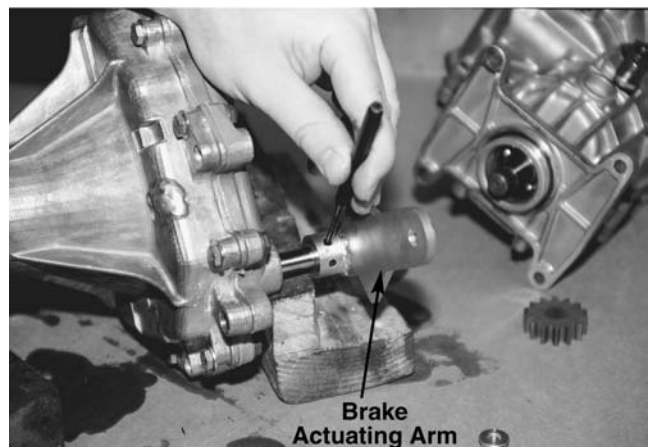
There is an “O” ring on the pump housing that should be inspected and replaced if necessary.

Also make sure that the sealing surface is clean and not scratched or damaged in any way.



**Figure 10-44.**

5. Remove the brake actuating arm from the shaft by supporting the shaft and housing with some blocks of wood so that you do not damage the shaft and components during disassembly. See Figure 10-45.



**Figure 10-45.**

**➡ NOTE**

Using a punch, tap out the roll pin to allow removal of the arm from the shaft.

6. To disassemble the housing halves remove the housing bolts with a 7/16 inch wrench and socket. See Figure 10-46.

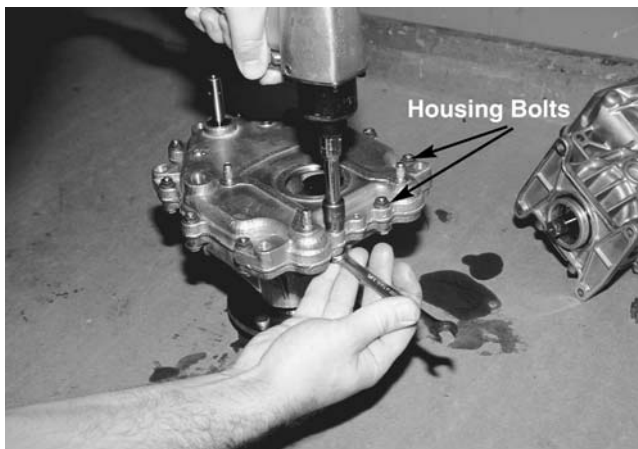


Figure 10-46.

**NOTE**

On production models of this transmission we will not be using washers on these bolts. During reassembly, it is important to remember not to overtighten these bolts and stretch them.

- To separate the housing halves, use a paint scraper or similar tool to pry the halves apart. Work around the housing to evenly release the housing halves. See Figure 10-47.

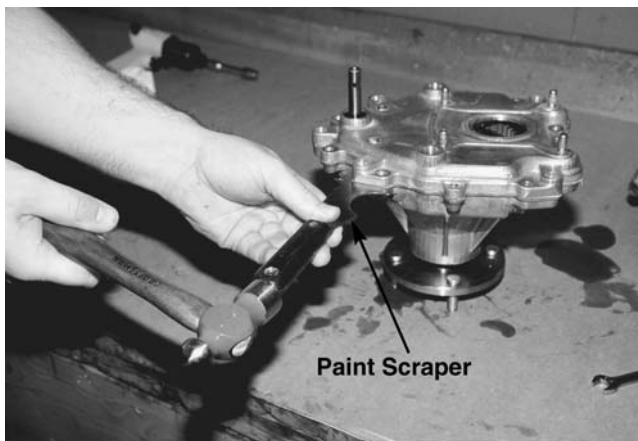


Figure 10-47.

**NOTE**

The needle bearing inside the housing half. Protect this bearing during repairs to keep dirt or foreign matter from damaging it. This is a press fit bearing. If it is damaged, it will have to be removed by prying or cutting it out without damaging the housing and pressing in a new bearing. Be sure that the face of the bearing seats below the surface of the housing.

- Visually inspect the parts in the housing. Check that the shim is in place and inspect the

gear teeth for any obvious damage. Remove the shim and make sure it is not waved like a potato chip, an indication of heat or excessive wear. See Figure 10-48.

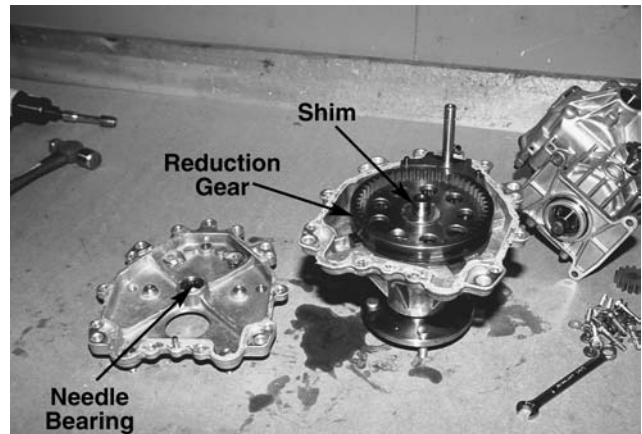


Figure 10-48.

- Remove the reduction gear and inspect for missing teeth or irregular wear patterns. See Figure 10-49.

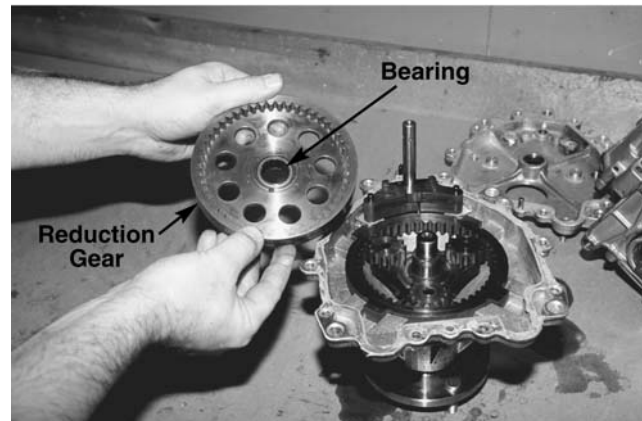


Figure 10-49

**NOTE**

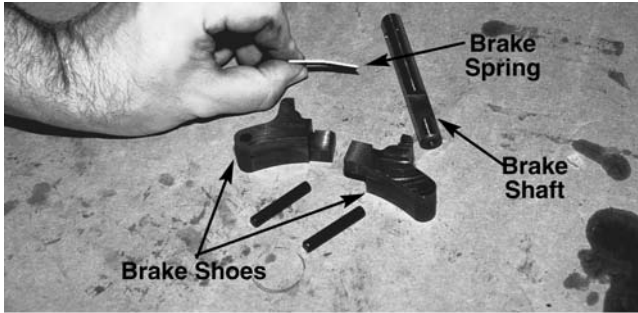
Inspect the bearing for any visible wear or damage and make sure that the bearing face is below the surface of the gear and centered within the gear.

Flip the gear over and inspect the teeth on the reduction gear for damage.

Production gears will not have the pins and screws and will be a one piece assembly.

- Remove the brake assembly by first removing the brake spring, then remove the brake shoes, shaft and two pins. See Figure 10-50.





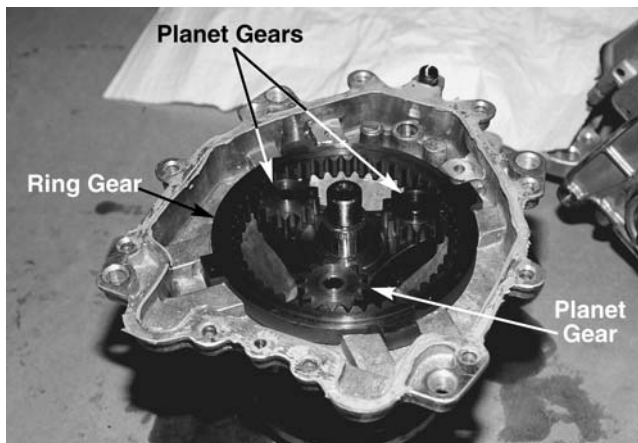
**Figure 10-50.**

**NOTE:** The parts then easily come apart. The shoes are symmetrical, are the same part and part number, and can be reassembled on either side.

The brake spring is slightly bent and should not be flat. Make sure it is not deformed or showing any signs of fatigue.

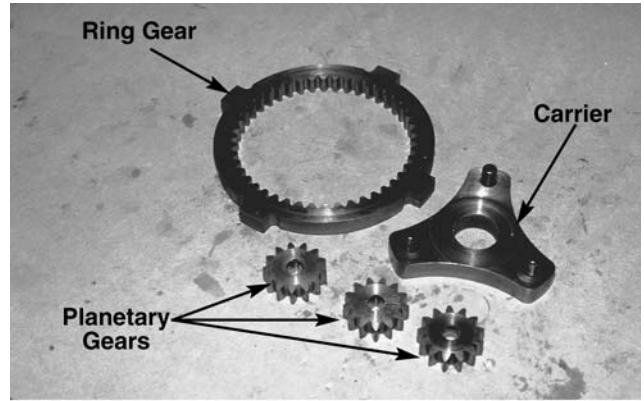
Inspect the brake shaft making sure that there is no excessive wear on the corners of the shaft and that the area where the seal rides is smooth and clean and not worn by the seal. This shaft has two holes. There will only be one hole in production units.

11. Remove the internals from the housing and inspect them for damage. See Figures 10-51 and 10-52.



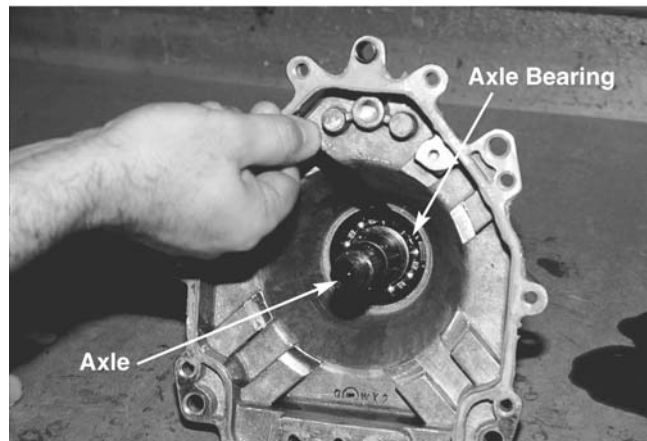
**Figure 10-51.**

12. Remove the ring gear, three planetary gears which come off the carrier, and the carrier which is splined to the shaft. All of these parts should be a slip fit and come off easily. See Figures 10-51 and 10-52.



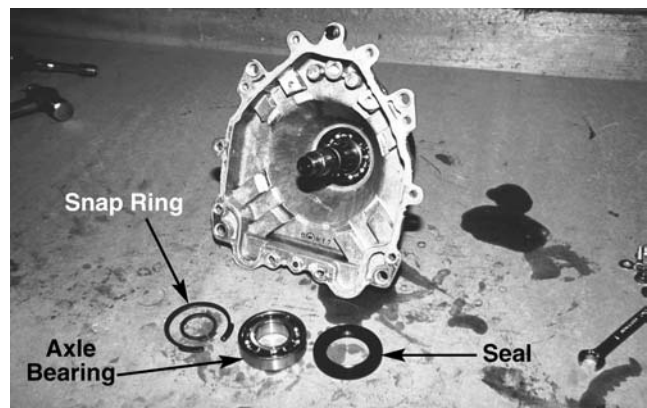
**Figure 10-52.**

13. The axle bearing is placed into the housing and is held by a snap ring that is used to keep the bearing in place under load. The axle is pressed through the bearing and is held in place by a smaller snap ring. See Figure 10-53.



**Figure 10-53**

14. Remove the axle from the housing, first remove the snap ring from the axle. See Figure 10-54.



**Figure 10-54.**

**➔ NOTE**

Support the housing using pieces of tubing. You want to support the housing on its body and not the ears which may break off. Leave enough travel for the axle to fall out and press on the end of the axle to remove it.

15. When you press the axle out of the bearing, you will need to replace the bearing because it will be damaged during removal. See Figure 10-55.



**Figure 10-55.**

16. To remove the bearing from the housing you must first remove the snap ring. See Figure 10-56.

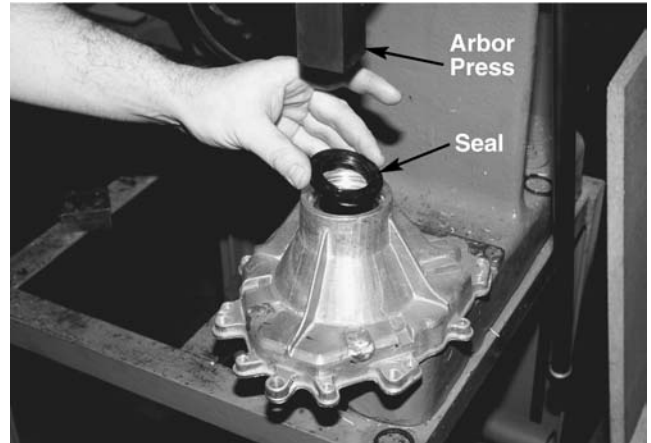


**Figure 10-56.**

**➔ NOTE**

Remove the bearing and discard. Remember, you must replace the bearing once the axle shaft has been pressed out.

17. Reassemble the axle, inspect the seal area of the housing for burrs or damage. The housing is chamfered so the seal starts easy and locates well. Using a piece of material close to the outside diameter of the seal so you are supporting it properly as you press it in. You will feel the seal bottom out against the shoulder of the inside of the housing. Inspect it to make sure it is seated properly. See Figure 10-57.



**Figure 10-57.**

18. Install the bearing. Set it into the housing so it goes down below the snap ring groove. See Figure 10-58.



**Figure 10-58.**

**➔ NOTE**

Install the large snap ring and seat it into the groove in the housing to retain the bearing.

**➔ NOTE**

To install the axle shaft and press it into the bearing, first support the shaft with a block so that pressure is not applied to the studs. Place the housing over the axle, and using a sleeve or some tubing that is close in size to the inner race of the bearing, press the bearing and housing down over the axle.

19. Install the snap ring on the axle shaft to retain the bearing on the shaft, making sure that the snap ring is in the groove on the axle. See Figure 10-59.

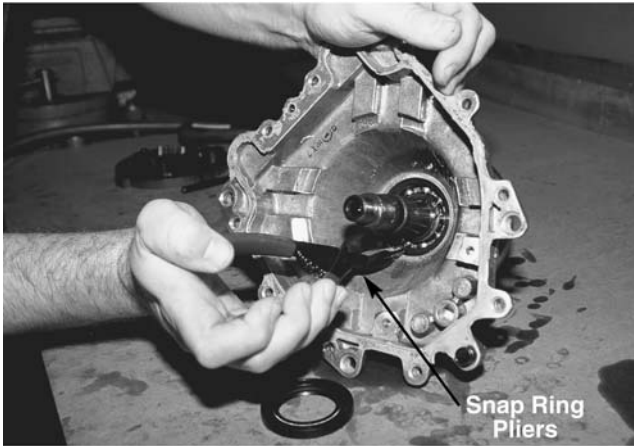


Figure 10-59.

20. If a stud becomes loose or broken and needs to be replaced, it is important to properly support the axle during this procedure in order not to put undue stress on the bearing. See Figure 10-60.

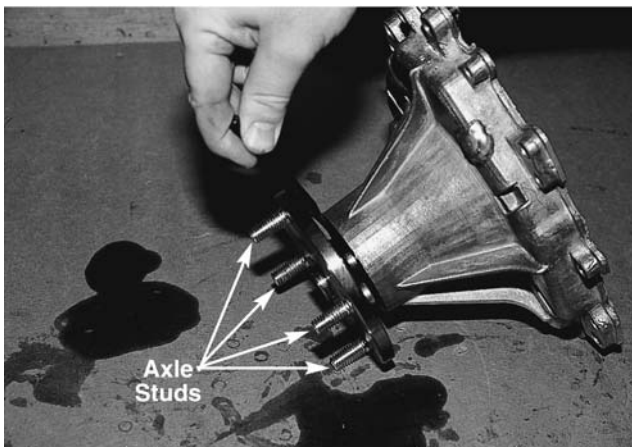


Figure 10-60.

**NOTE**

To make replacing a stud easier, line up the serrations of the stud with the axle plate and press the stud through the plate. Using a spacer and the nut, or the tire rim itself, tighten

the nut to draw the bolt through the plate, seating it completely.

21. Before reassembly, clean the housing and remove old gasket material. Use a rag to protect the bearing before cleaning to avoid damage. Take a paint scraper or other tool and remove all gasket material. Do this to both housing halves and then wipe down the mating surfaces to remove any grease or oil from them. See Figure 10-61.



Figure 10-61.

22. Install the brake components by installing the brake actuating shaft into the housing, then installing the brake shoes next, one inverted next to the other. Insert the two dowel pins through the brake shoes into the housing, then insert the brake spring with the bend around the shaft. See Figure 10-62.

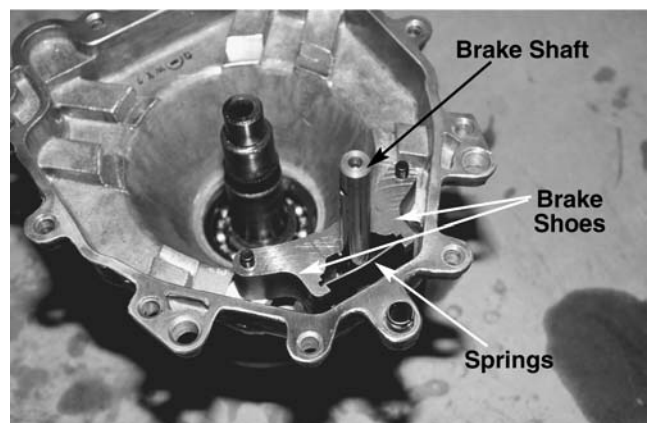


Figure 10-62.

23. Install the ring gear into the housing. It has four tabs and should rest in the housing and be loose. See Figure 10-63.

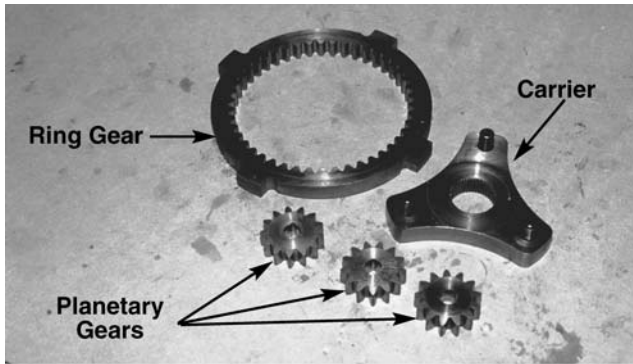


Figure 10-63.

**NOTE**

Install the carrier onto the splines by lining up the splines and sliding it down onto the shaft.

Install the three planetary gears. They have lubrication grooves on one side and should be installed with these grooves down.

Make sure everything turns smoothly.

Then install the reduction gear with the small gear down, inserting it through the planetary gears and sliding it down the shaft, making sure that the whole assembly turns smoothly as well.

24. Prior to assembling the two housings together, make sure that there is proper clearance between the gear and inner housing by measuring the distance from the mating surface of the housing to the boss on the center of the housing. See Figure 10-64.

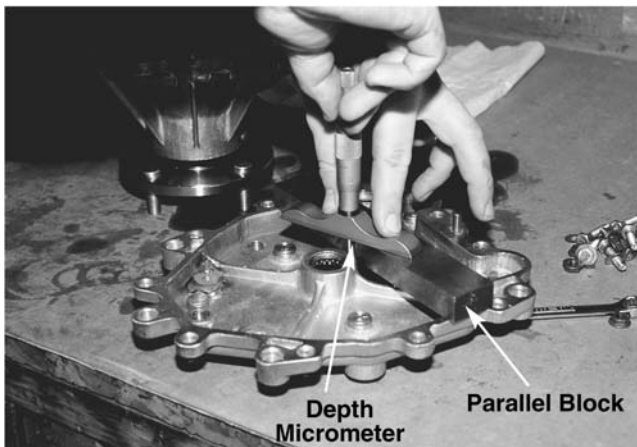


Figure 10-64.

**NOTE**

Using a parallel and a depth micrometer, measure the distance to the boss and subtract the

height of the parallel to arrive at the distance from the housing mating surface to the center boss. Write that number down for reference.

25. Using parallels, measure the distance from the mating surface of the large housing down to the first shoulder on the axle shaft. Subtract the height of the parallels to arrive at the distance between the mating surface and shoulder. This measurement should be greater than the number for the smaller housing. See Figure 10-65.

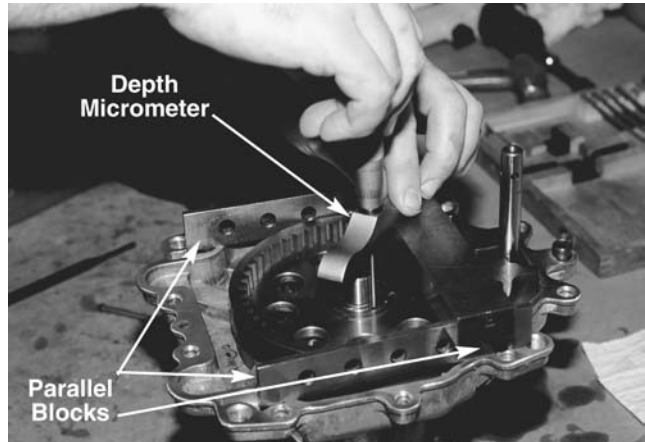


Figure 10-65.

26. Shim the axle with hardened washers to achieve five to 20 thousandths clearance. This provides play without binding. See Figure 10-66.

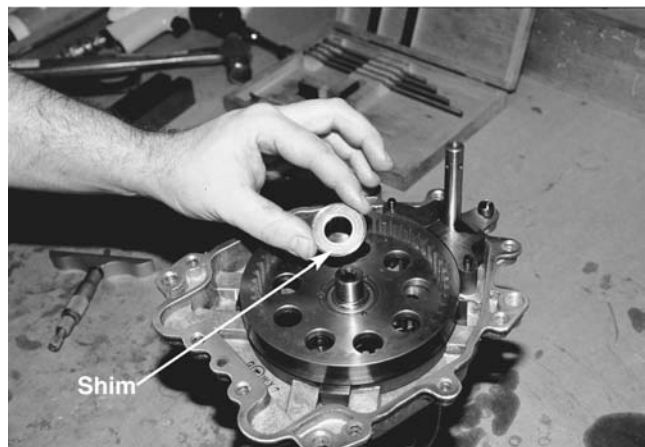


Figure 10-66

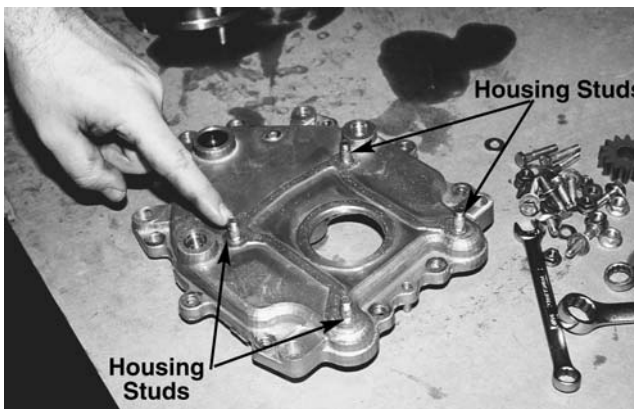
27. Prior to installing the two housing halves, inspect the seal to make sure the spring is in place and the lip has not been damaged during disassembly. If it needs to be replaced, pry the seal from the housing, making sure not to mar the surface the seal gets pressed in to. Press a new seal into place making sure that the top

surface of the seal is below the housing surface. See Figure 10-67.



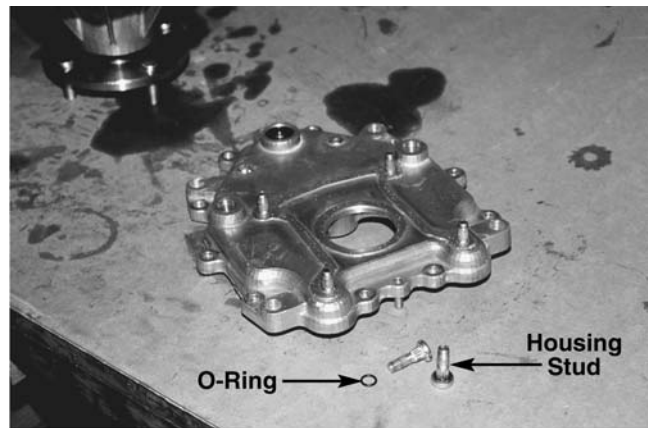
**Figure 10-67.**

28. Before installing the smaller housing inspect the four studs and make sure they are in place and not loose in the housing. See Figure 10-68.



**Figure 10-68.**

29. There is an "O" ring on the stud and a sealing surface cut into the housing on the opposite side. If the studs are loose, but still in the housing, they can be used but cannot be allowed to fall into the housing during assembly. If the housing will not retain the studs you will need to replace the housing. See Figure 10-69.



**Figure 10-69.**

30. Prior to applying Loctite sealer, make sure the mating surfaces are clean and free from dirt and oil. Apply a 1/16 inch bead of sealer around the inner surface of the housing. Applying too much sealer and allowing it to get inside the transmission can hinder the performance of the transmission. See Figure 10-70.



**Figure 10-70.**

31. Before installing the smaller housing place a light coating of oil on the brake shaft and check to be sure the needle bearing is lubricated. See Figure 10-71.

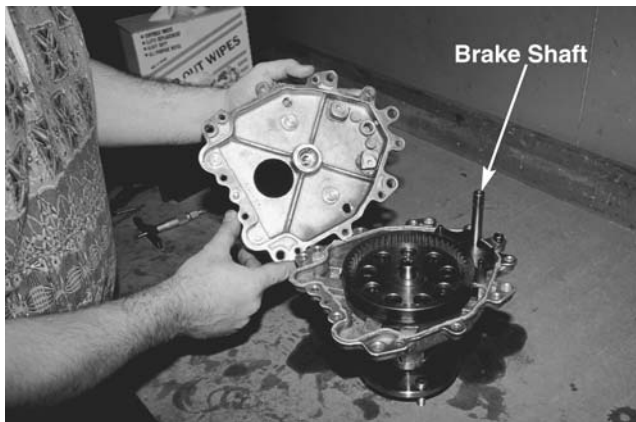


Figure 10-71.

32. Install the housing over the brake shaft, being careful with the seal, align the axle shaft with the bearing and press the two halves together. See Figure 10-72.

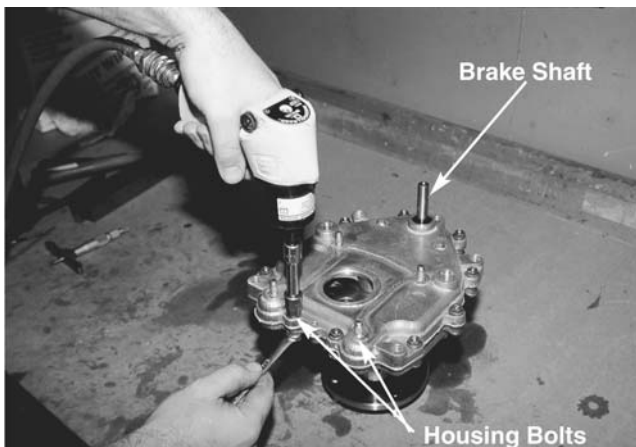


Figure 10-72.

**NOTE**

Install the ten perimeter bolts with the head of the bolt on the underside and the lock nut on top. These bolts have washers, the production models will not.

If using an air tool, use caution not to over-tighten the bolts. Torque between 60 and 85 inch pounds.

33. Prior to installing the pump onto the housing be sure that the "O" ring is in place on the pump. Set the pump up on its end and install the input pinion gear on the pump shaft. See Figure 10-73.

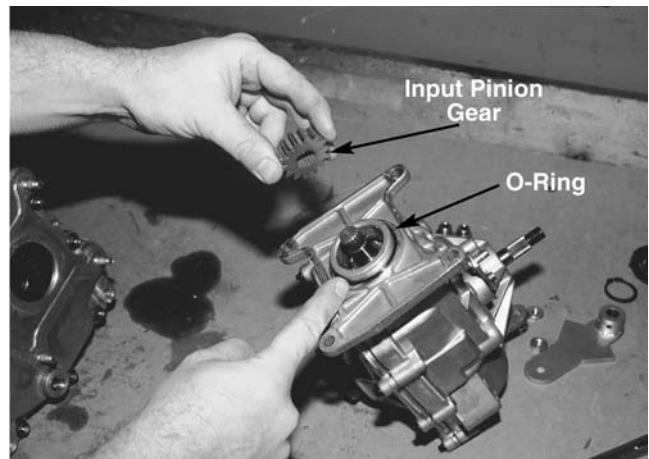


Figure 10-73.

34. Align the studs with the transmission, and be careful not to push the studs into the transmission, mate the two halves together. See Figure 10-74.

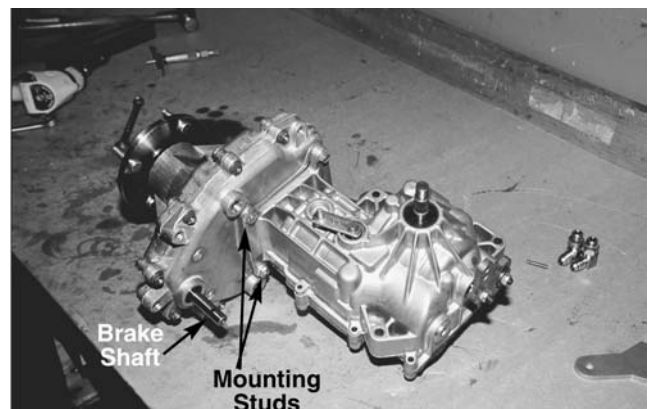


Figure 10-74.

**NOTE**

The ZT tractor transmissions and pumps are the same for each wheel but the pump is reversed on one side. Make sure you orient the pump properly.

Install the four nuts retaining the pump to the transmission using a 1/2 inch wrench. Make sure the "O" ring is compressed and the four ears of the pump are flush with the housing.

Torque to specifications.

35. Install the hydro fitting by backing off the nut so the washer is loose. Screw the fitting into the housing part way, leaving it loose so that you can align the fitting with the frame and other parts installed on the tractor. During installation

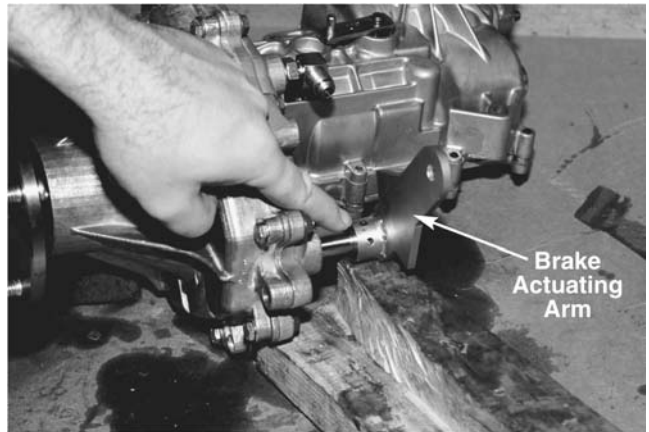


make sure the seats are clean and the “O” rings are in good condition. See Figure 10-75.



**Figure 10-75.**

36. Reinstall the brake actuating arm by properly bracing the shaft and driving the pin into the hole and through the shaft. See Figure 10-76.



**Figure 10-76.**

# 624 Zero Turn Tractor - The Revolution



Figure 11-1

## Introduction

The Revolution is a front engine zero turning radius lawn tractor that is based on the step through platform which was introduced last year. The steering wheel has been replaced with a pair of control handles. Each lever independently controls the left and right integrated zero-turn transmissions (IZTs), which direct the rotation of each rear wheel assembly.

The front pivot bar has been replaced with a caster wheel pivot bar.

The revolution will accept the following FastAttach™ accessories.

- Front bumper - OEM-190-603 (Standard)
- Rear grass collector - (OEM-190-625 - 38"-42" decks) - (OEM-190-626 - 46" deck)
- Rear weights - (Standard)
- Snow blade - OEM-190-822
- Tire chains - 723-0490

## ➔ NOTE

The Revolution will not accept a snow thrower or any ground engaging implements. The mower deck is similar to that of the step through design, but they are not interchangeable.

## Control Layout

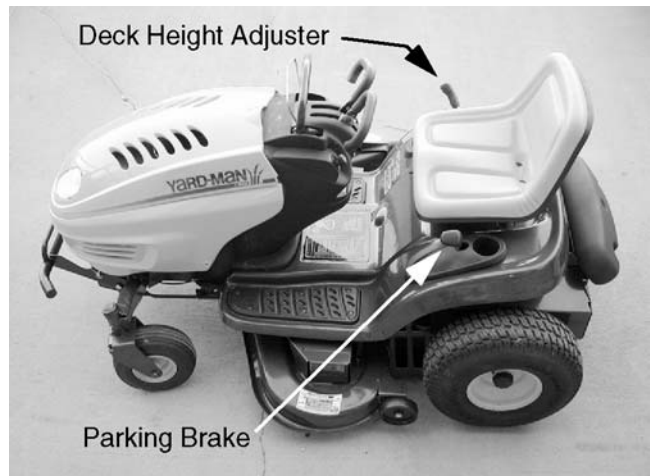


Figure 11-2

- Parking Brake lever in "J" slot, located on left rear fender.
- Deck Height lever in notched slot, located on right rear fender.
- IZT Relief Valves rods on either side of the weight bracket on the rear frame. See Figure 11-3.

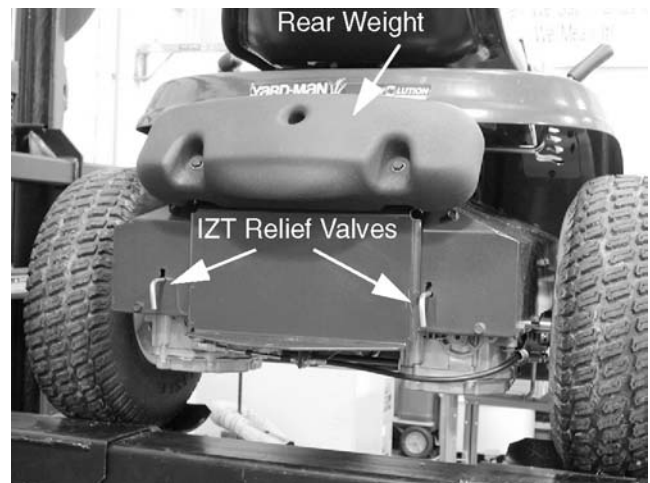
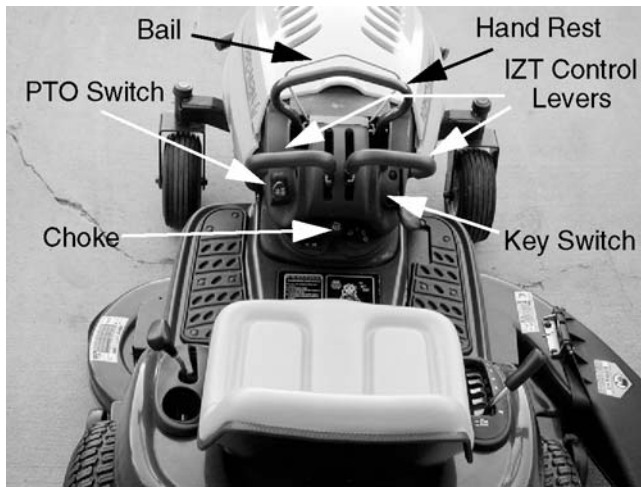


Figure 11-3

- IZT Control levers at the top of the dash panel. See Figure 11-4.





**Figure 11-4**

- Adjustable Hand Rest In front of the control levers, adjustable by squeezing a bale.
- Throttle top right of dash panel.
- Key Switch lower right of dash panel.
- PTO Switch top left of dash panel.

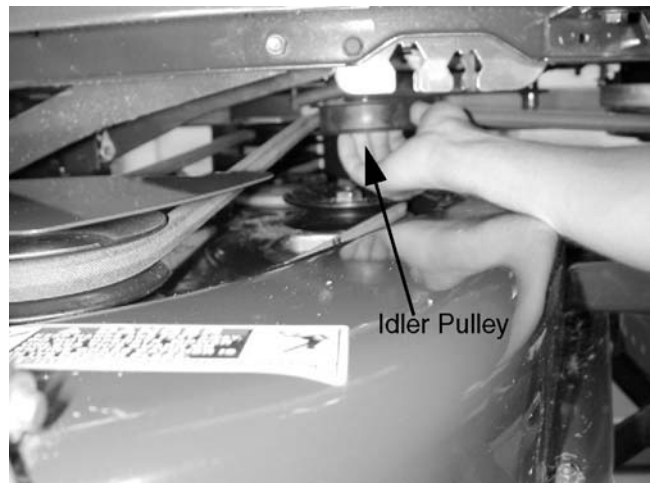
## 46" Cutting Deck

### Upper Belt Removal



It is not necessary to remove the cutting deck from the machine to replace the engine-to-deck drive belt.

1. Set the deck height lever to the lowest position.
2. Remove the belt guards that cover both spindle stack pulleys using a 3/8" wrench.
3. Relieve the belt tension pulley. See Figure 11-5.



**Figure 11-5**

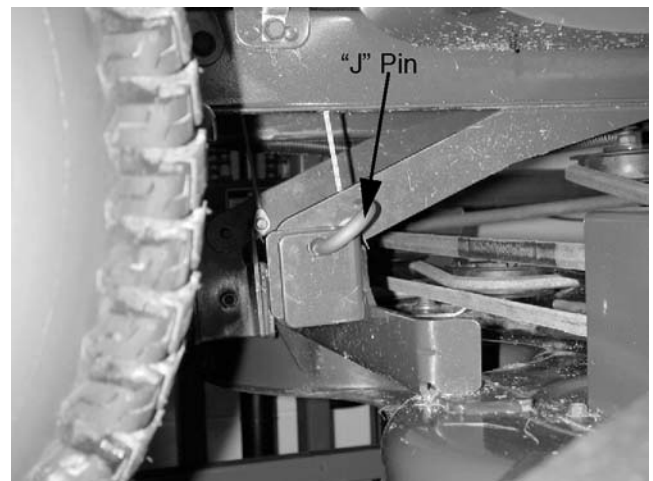
4. Roll the belt off of the PTO clutch and spindle stack pulleys.
5. Remove the belt.
6. Install the belt in the reverse order above.

### Cutting Deck Removal



Deck removal is similar to the conventional step through design.

1. Set the deck height lever to the lowest position.
2. Pull outward on the rear "J" pins and rotate them to lock them in the out position. See Figure 11-6.



**Figure 11-6**

3. Push the deck forward to release it from the front stabilizer rod.

**NOTE**

This will relieve the belt tension.

4. Roll the belt off of the PTO clutch and remove the mower deck from beneath the tractor.
5. Install the deck in the reverse order above.

### Lower Deck Belt Removal

**NOTE**

Prior to performing this section, perform the cutting deck removal section.

1. Remove the belt guards that cover both spindle stack pulleys, using a 3/8" wrench.
2. Record the belt routing. See Figure 11-7.

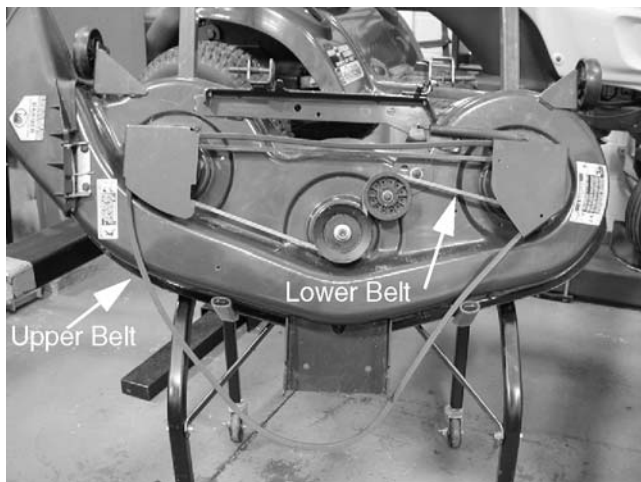


Figure 11-7

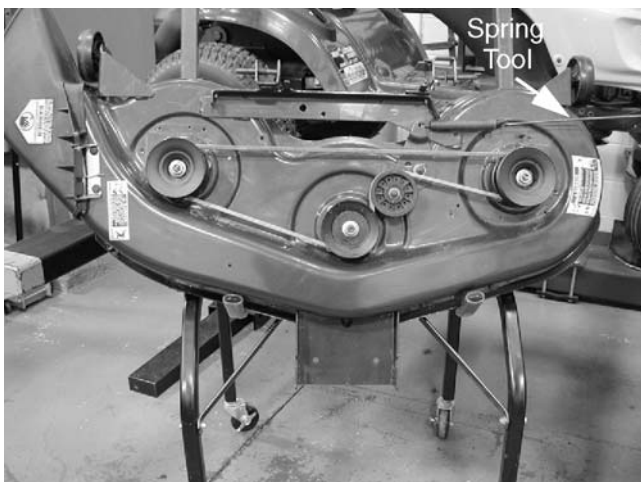


Figure 11-8

3. Relieve the belt tension pulley spring using recoil rope or a spring tool #732-0531. See Figure 11-8.
4. Roll the belt off of the deck pulleys.
5. Reinstall the belt in reverse order above.

### Servicing the IZT Drive Belt

**NOTE**

Prior to performing this section, the cutting deck removal section must be performed.

1. Record the routing of the drive belt.
2. Remove the double idler pulley bracket extension spring from the frame using a recoil rope.

**NOTE**

This will relieve the belt tension. See Figure 11-9.

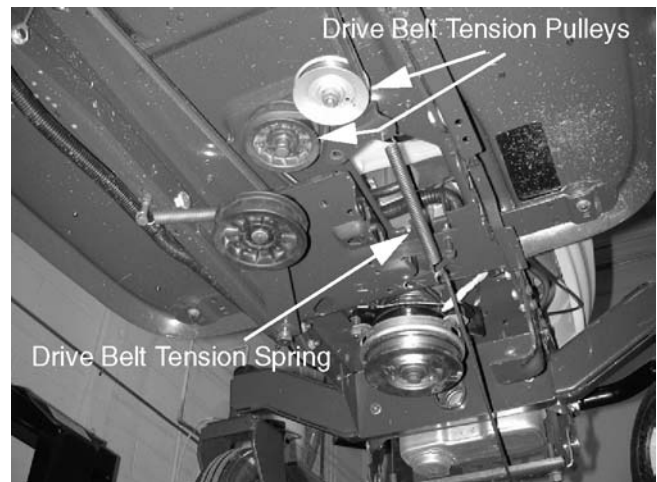


Figure 11-9

3. Cut the tie strap that secures the yellow wrapped PTO clutch wire to the harness. See Figure 11-10.



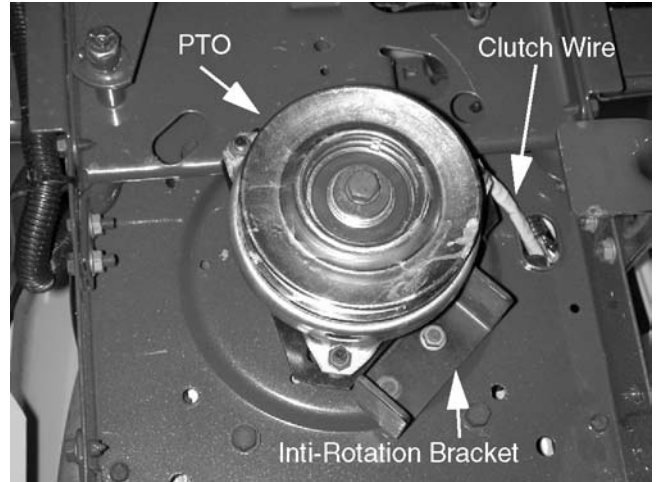
**Figure 11-10**

4. Unplug the PTO clutch connector using a flat blade screw driver. See Figure 11-11.



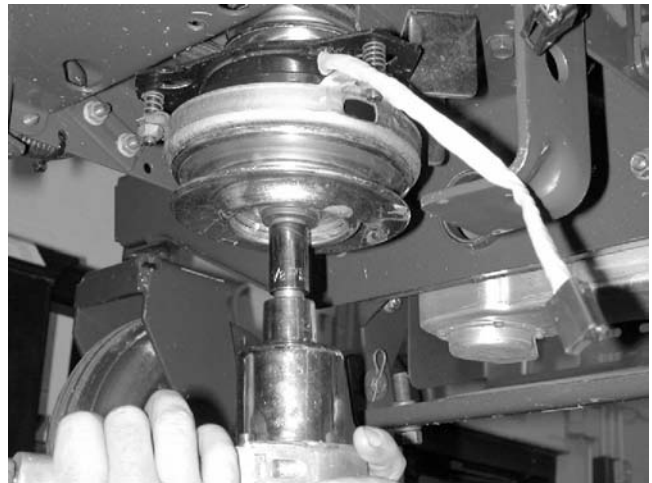
**Figure 11-11**

5. Record the position of the PTO clutch anti-rotation bracket and yellow PTO clutch wire. See Figure 11-12.



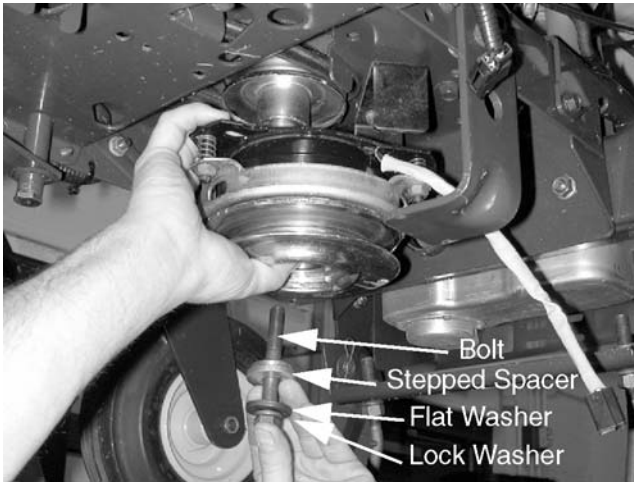
**Figure 11-12**

6. Loosen the PTO clutch retaining bolt with a 5/8" socket. Hold onto the PTO clutch with one hand. See Figure 11-13.



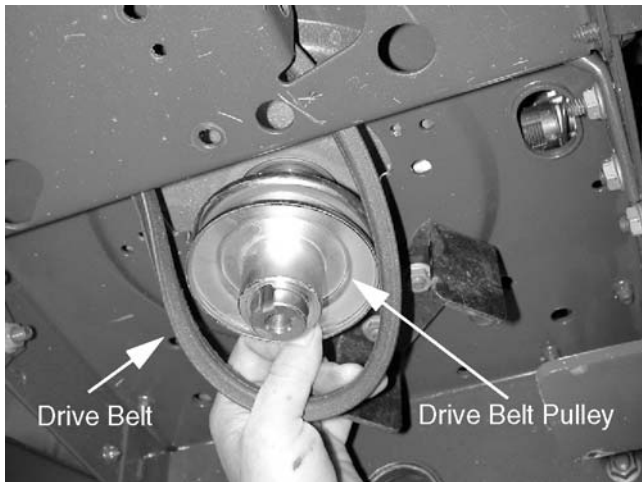
**Figure 11-13**

7. Remove the bolt, lock washer, flat washer, and stepped spacer with your other hand. Note the position of the hardware. See Figure 11-14.



**Figure 11-14**

8. Remove and set aside the PTO clutch.
9. Slide the drive belt pulley off the bottom of the crankshaft. See Figure 11-15.

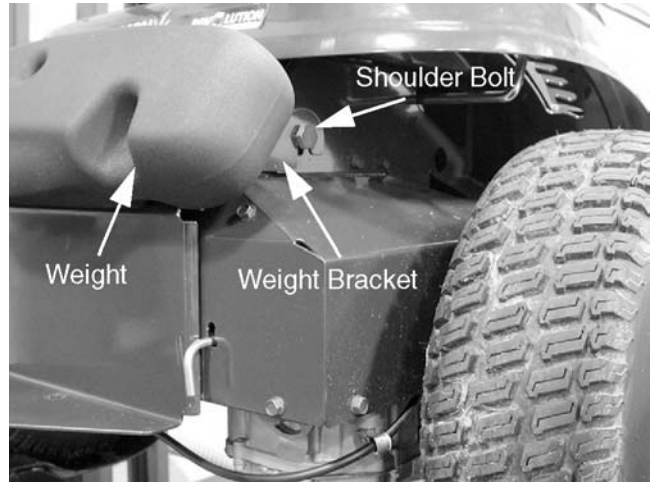


**Figure 11-15**

**➡ NOTE**

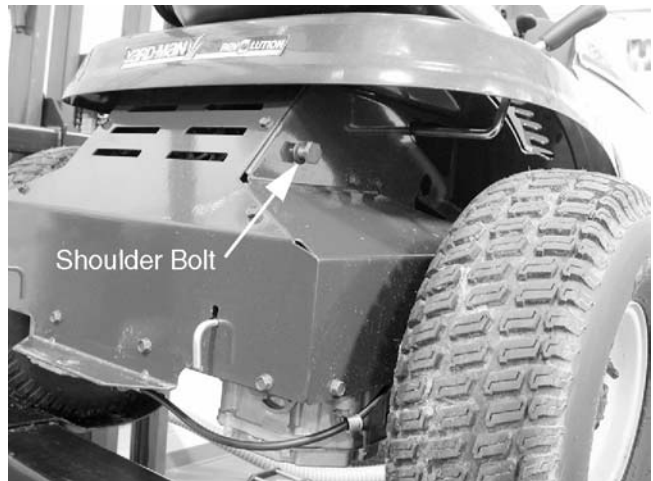
On installation of the pulley the beveled ID goes up, to mate with the radius at the crank-shaft step.

10. Remove the clevis pin that secures the weight bracket to the back of the tractor.
11. Lift the weight bracket off of the shoulder bolts on the frame, and set it aside. See Figure 11-16.



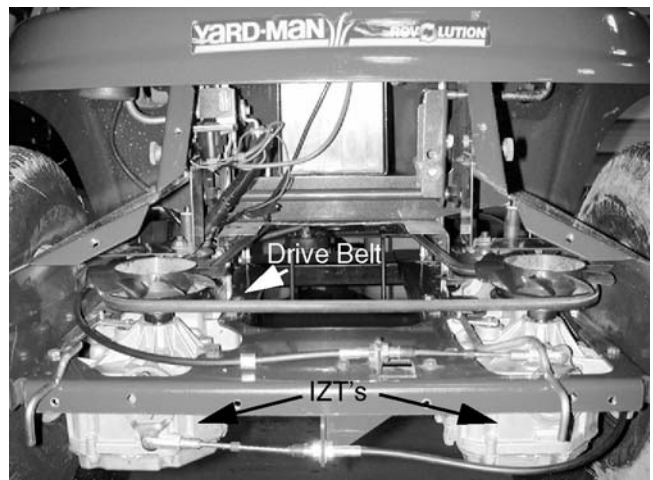
**Figure 11-16**

12. Remove the bolts that hold the rear cover to the frame using a 1/2" wrench. See Figure 11-17.



**Figure 11-17**

13. Remove the rear cover. See Figure 11-18.

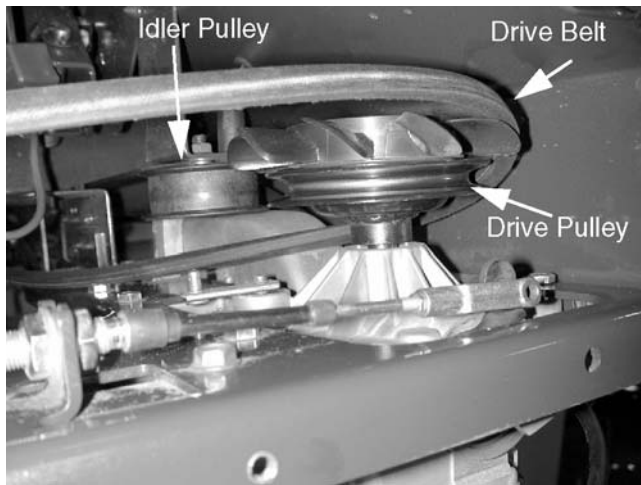


**Figure 11-18**

**➔ NOTE**

Removing the rear cover provides easy access to the belts, IZTs, solenoid, seat safety switch, and many control linkages.

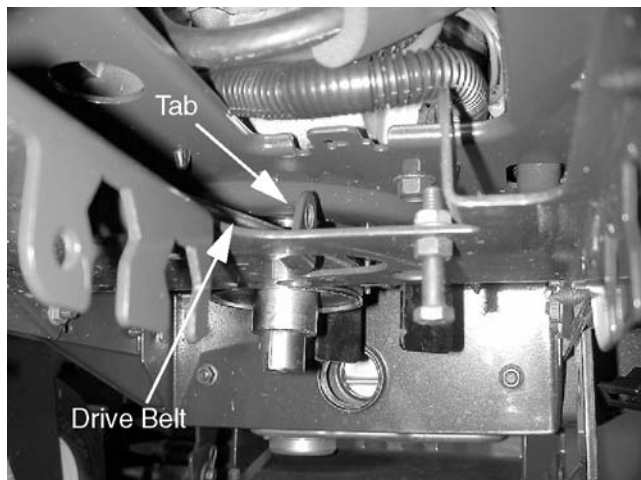
14. Slip the drive belt out from between the tension pulleys.
15. Remove the drive belt from the idler pulleys and the drive pulleys on top of the IZTs, and withdraw it from the back of the tractor. See Figure 11-19.



**Figure 11-19**

**➔ NOTE**

When installing the belt, make certain to route the belt inside of tab. The tab is a bracket used for the RT99 application of this frame. See Figure 11-20.



**Figure 11-20**

**➔ NOTE**

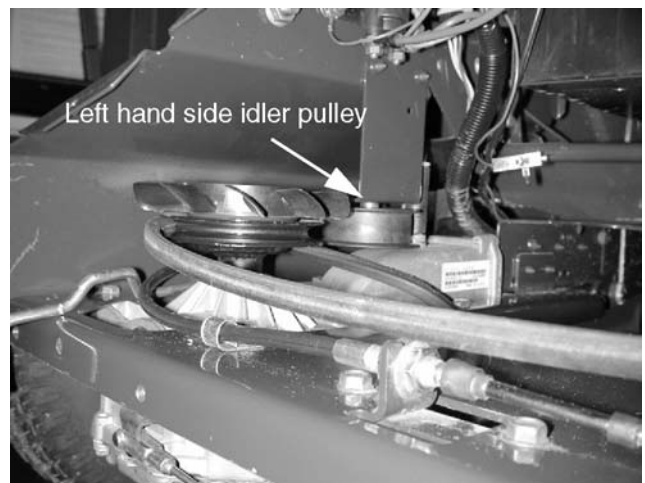
If the right pulley must be replaced it can be unbolted from its bracket. See Figure 11-21.



**Figure 11-21**

**➔ NOTE**

To replace the left hand side pulley you must remove the pulley with its mounting bracket. See Figure 11-22.



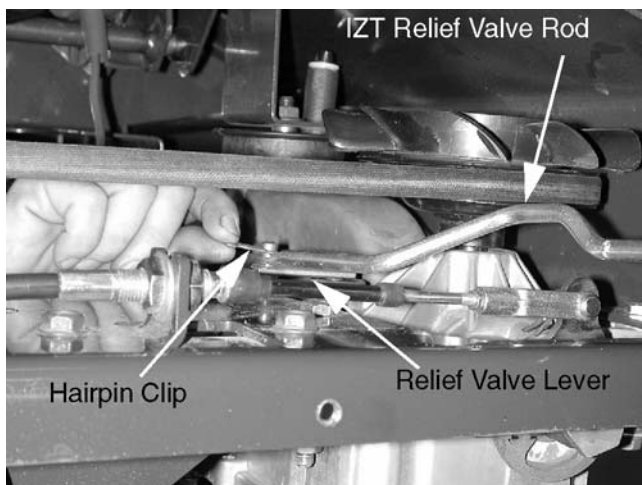
**Figure 11-22**

**Servicing the IZT**

**➔ NOTE**

If an IZT is not performing properly, check all external factors before removing it for internal service or replacement:

- a. Make certain the brakes are not dragging or out of adjustment. See Figure 11-23.



**Figure 11-23**

- b. Make certain the control cables are not binding or out of adjustment.
- c. Make certain the belt is not slipping.
- d. Check the air pressure and circumference of each rear tire. (12-14 psi.)
- e. Check the front tires for correct air pressure and freedom of rotation. (30 psi.)
- f. When ordering replacement IZT units or parts, make certain to specify the correct side you are working on.

**→ NOTE**

The left and right IZTs are similar to each other, but not identical.

**→ NOTE**

Prior to removing this section, perform the Servicing the IZT Drive Belt section.

**→ NOTE**

It is not necessary to remove the belt from the engine pulley.

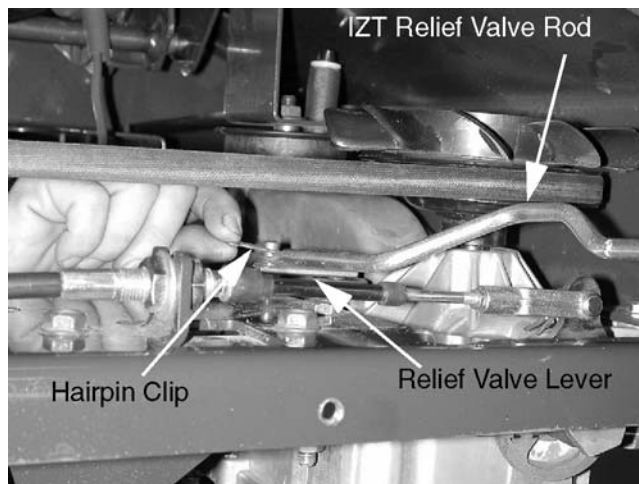
1. Raise the rear of the tractor far enough in the air to allow clearance for the IZT to fit beneath the frame.
2. Support the tractor securely, by the frame.

3. Unbolt and remove the rear wheel using a 9/16" wrench.

**→ NOTE**

A small hub cap snaps over a large flat washer beneath the head of the bolt. A bellville washer fits between the flat washer and the end of the axle. When installing the wheel, make certain the bellville washer is facing the correct direction.

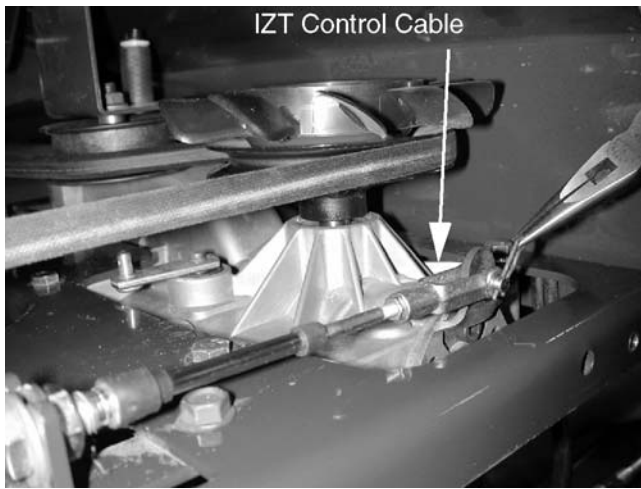
4. Release the parking brake.
5. Disconnect the actuating spring leading upwards from the brake caliper.
6. Remove the hairpin clip that holds the relief valve rod to the relief valve lever on the IZT. Remove the rod. See Figure 11-24.



**Figure 11-24**

7. Remove the hairpin clip and clevis pin that holds the control cable to the control arm on the IZT. See Figure 11-25.

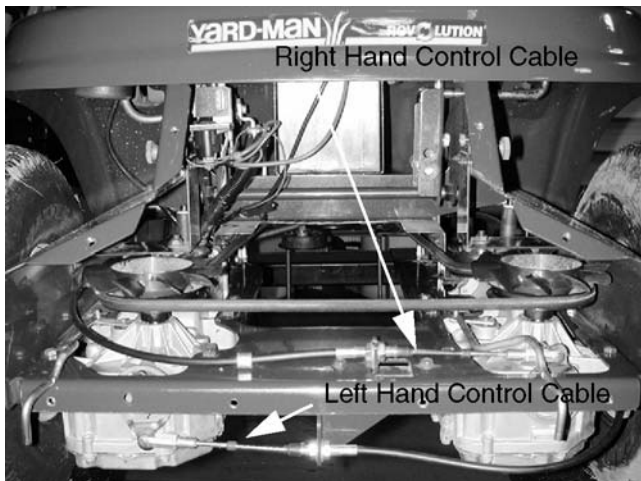




**Figure 11-25**

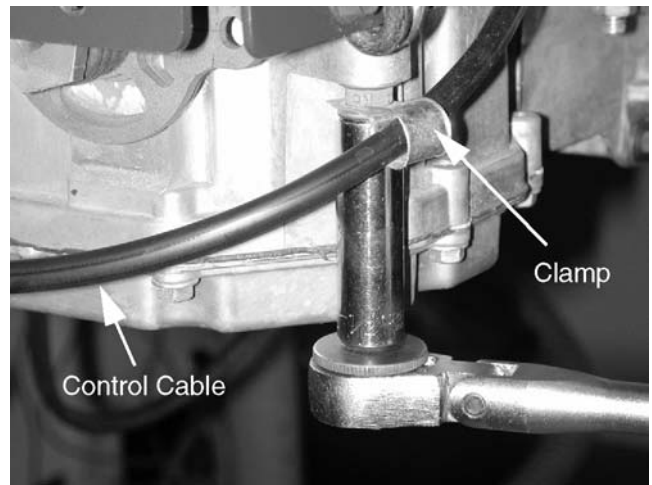
**NOTE**

The control arm on the right IZT is above the frame. The control arm on the left hand side IZT is beneath the frame. Each control cable approaches the IZT from the opposite side of the frame, and is fastened to the opposite IZT by a clamp. See Figure 11-26.



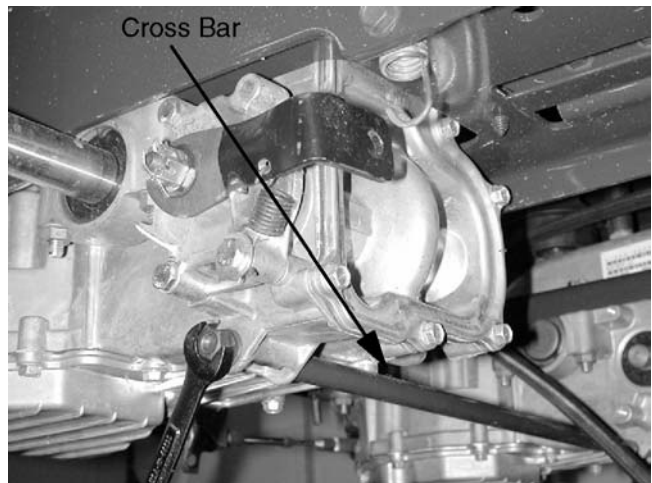
**Figure 11-26**

8. Remove the nut and clamp which secures the control cable to the IZT using a pair of 1/2" wrenches. See Figure 11-27.



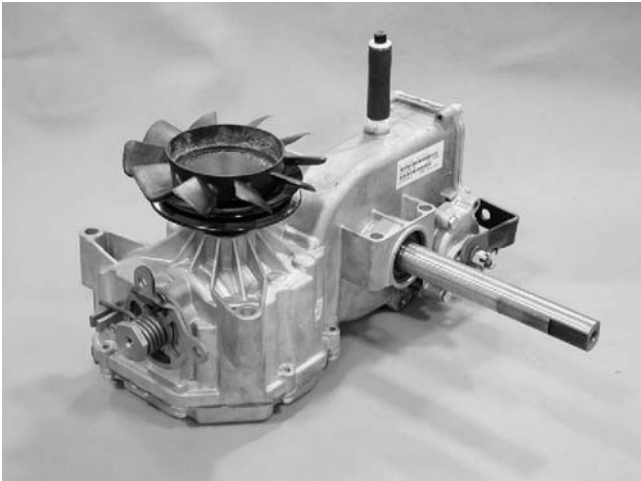
**Figure 11-27**

9. Remove the cross bar and tube from between the two IZTs using a pair of 1/2" wrenches. See Figure 11-28.



**Figure 11-28**

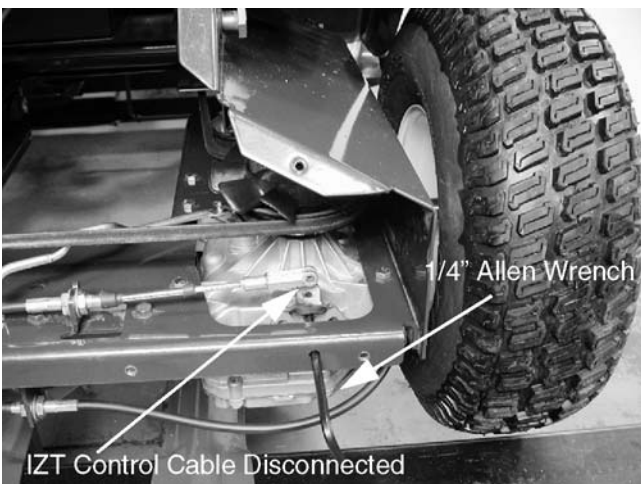
10. Loosen two diagonally opposed IZT mounting bolts using a pair of 1/2" wrenches.
11. Remove the remaining four bolts that fasten the perimeter of the IZT to the tractor frame using two 1/2" wrenches.
12. While supporting the IZT, carefully remove the two remaining nuts and bolts, then lower the IZT out of the tractor. The IZT must be tilted slightly to allow the cooling fan to clear the frame. See Figure 11-29.



**Figure 11-29**

13. Install in the reverse order.

### Adjustments to the IZT



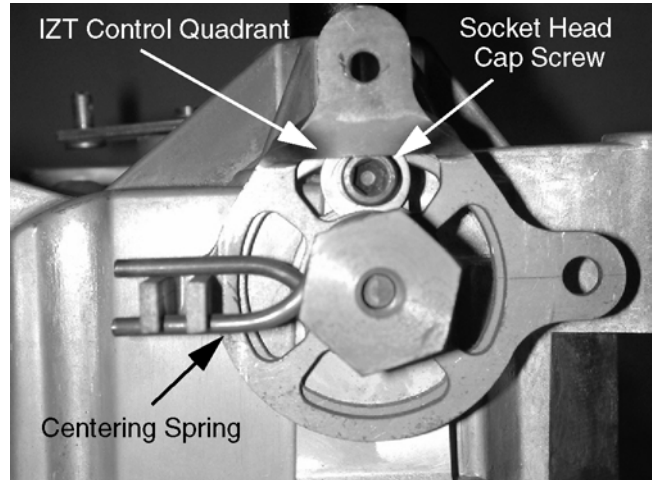
**Figure 11-30**

1. Remove any rear mounted accessories. See Figure 11-30.
2. Remove the rear cover from the tractor frame using a 1/2" wrench.
3. Raise both rear wheels off the ground and support the rear of the tractor by the frame.

#### ➡ NOTE

- Make certain both relief valves are fully closed.
4. Remove the hairpin clips and clevis pins that secure both control cables to the IZTs.

5. Use a paint pen or marker to index the control lever quadrant and the IZT case.
6. Start the engine, release the parking brake, and watch the rear wheels.
7. Turn off the engine.
8. If either wheel rotates forward or backward, the control lever quadrant on its' IZT must be adjusted using a 1/4" allen wrench. See Figure 11-31.



**Figure 11-31**

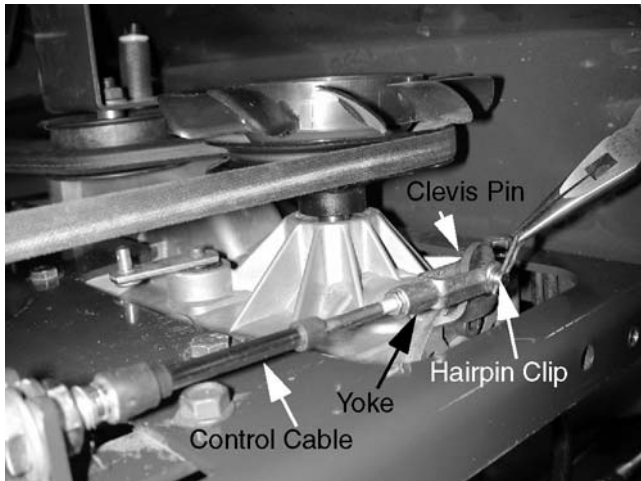
9. Loosen the socket head cap screw, rotate the control lever quadrant slightly, then secure it by tightening the socket head cap screw.

#### ➡ NOTE

The adjustment is quite sensitive, so it may take a couple of tries to find neutral. The adjustments of the two IZTs move in opposite directions. Note the direction the cable pulls to see which direction to adjust the control lever quadrant.

10. The control lever quadrants are set correctly when neither wheel rotates with the engine running and the parking brake released.
11. Adjust the control cables so that the clevis pins can be easily inserted through the yoke and control lever. See Figure 11-32.





**Figure 11-32**

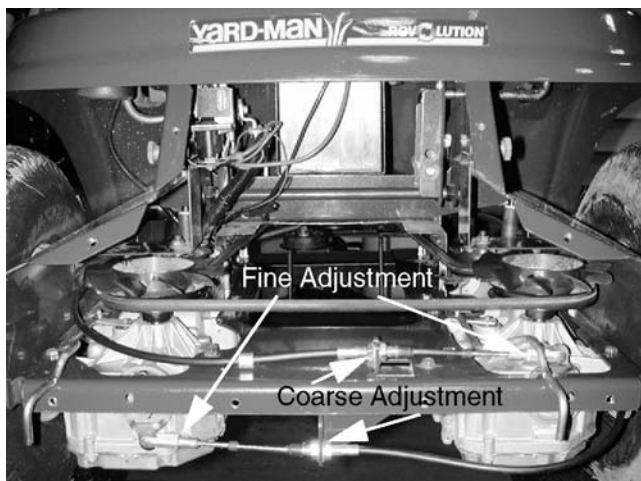
- There may be a slight amount of play (.060") to the cable. Remove this play by pushing in on (retracting) the yoke, but do not push hard enough to cause the control handles to move.

**NOTE**

The damper cylinders at the dash panel end of the cable will center the cables to the neutral position.

**NOTE**

The adjustment nut and jam nut that hold the cable housing in place on its bracket are good for coarse adjustment. Centering the bracket on the threads is a good starting point. Fine adjustment, if necessary, can be done at the end of the cable by loosening the Jam nut and adjusting the yoke. See Figure 11-33.



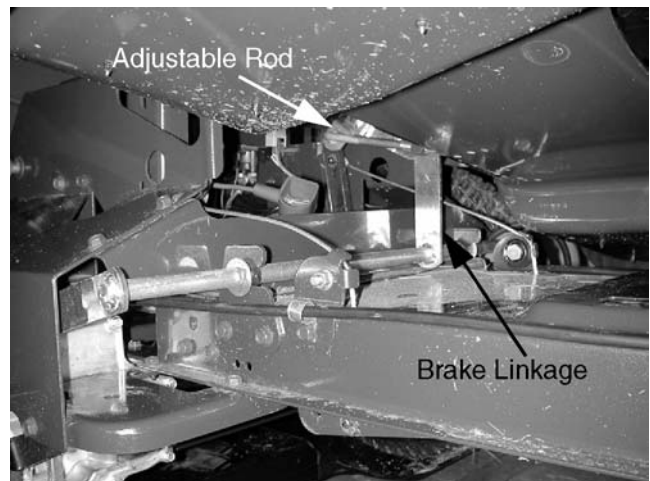
**Figure 11-33**

## Parking Brake

- Correct brake operation can be checked by engaging the parking brake, open both IZT relief valves, and push the tractor forward **and** reverse. There is a separate brake for each rear axle, and you should not be able to push either side.
- When the parking brake is released, the tractor should roll when pushed.
- There will be some drag from the pumps in the IZT's even when the relief valves are open.

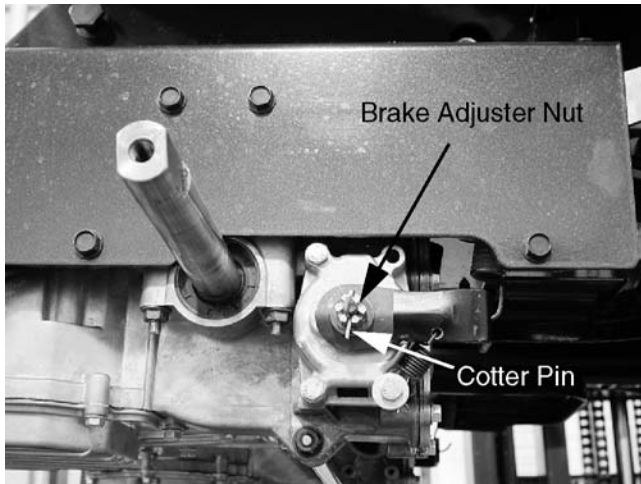
**NOTE**

If either of these conditions are not met, check both brake calipers and linkage for proper adjustment. See Figure 11-34.



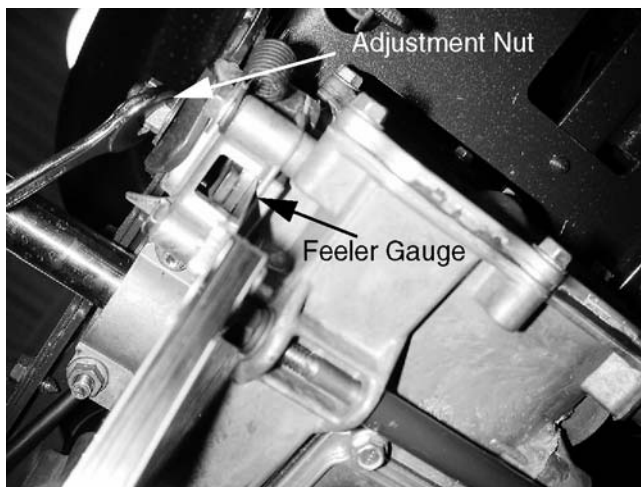
**Figure 11-34**

- To access the linkage, remove the clevis pin that secures the weight bracket to the back of the tractor.
- Lift the weight bracket off of the shoulder bolts on the frame, and set it aside.
- Remove the bolts that secure the rear cover to the frame using a 1/2" wrench, and remove the cover.
- Lengthen or shorten the rod that connects the brake lever bell-crank to the cross shaft assembly to set the application point of the parking brake.
- To check the caliper adjustment: Raise the rear wheels off the ground, and support the tractor by the frame. See Figure 11-35.



**Figure 11-35**

9. Unbolt and remove both rear wheels using a 9/16" wrench.
10. Release the parking brake.
11. Remove the cotter pin that locks the castle nut on to the center stud of one brake caliper
12. Loosen the nut slightly, and insert a .020" feeler gauge between the brake rotor and the brake pad. See Figure 11-36.



**Figure 11-36**

13. Tighten the nut until slight drag is felt on the feeler gauge.
14. Remove the feeler gauge.

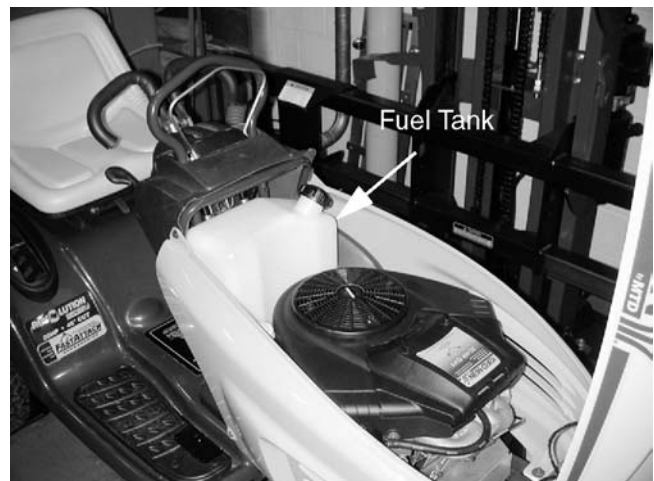
15. Turn the nut until the nearest slot in the castle nut lines up with the hole in the stud.
16. Insert a new cotter pin and bend the ends in opposite directions using needle nose pliers.
17. Repeat the process on the other side.
18. Reinstall the wheels.
19. Set the parking brake.
20. Lower the tractor to the ground.
21. Torque the wheels to 450 to 600 in. lbs.

## Under Dash Service Points



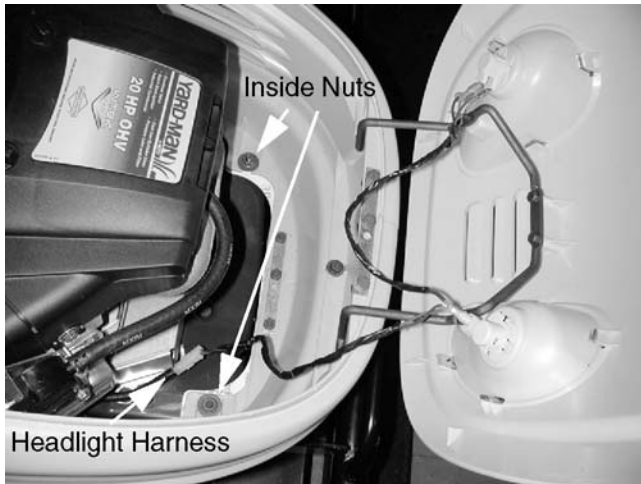
By removing the fuel tank, access is gained to the following components: key switch; PTO switch; hour meter; control lever cylinders; reverse safety switches.

1. Open the hood. See Figure 11-37.



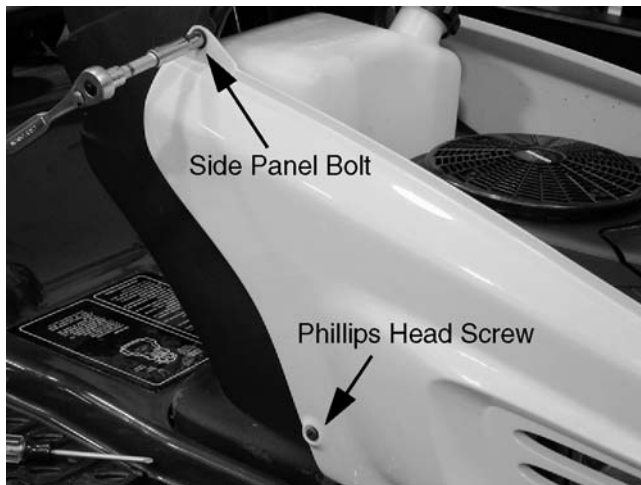
**Figure 11-37**

2. Unplug the headlight harness from the main harness at the molded plug.
3. Remove the nuts at the front inside corners of the side panels using a 1/2" wrench. See Figure 11-38.



**Figure 11-38**

4. Close the hood.
5. Remove the bolts at the upper rear corner of each side panel using a 3/8" wrench. See Figure 11-39.



**Figure 11-39**

6. Remove the phillips head screws at the lower rear corner of each side panel.
7. Carefully lift the hood and side panel assembly away from the tractor, and place it out of the way.
8. Drain the fuel tank into an approved container,

**NOTE**

Avoid any fire hazards. See Figure 11-40.



**Figure 11-40**

9. Remove the four bolts that secure the fuel tank to the dash support tube, using a 1/2" wrench.
10. Move the fuel tank to the side.
11. Install in the reverse order of removal.

### Dash Panel Removal

**NOTE**

Prior to performing this section, perform fuel tank removal.

**NOTE**

The rear fenders must also be loosened and moved rearward to gain access to some dash panel hardware.

**NOTE**

Access to some service items will require the removal of the dash panel.

Those items are:

- IZT control lever pivot bar
- Neutral safety switches
- Wiring harness
- Choke cable.

**NOTE**

It is not necessary to remove the dash panel to replace the I.H.T. control cables, but lifting the rear

fenders out of the way provides easy access to the cables. See Figure 11-41.



**Figure 11-41**

1. Prior to performing this section, perform hood removal.
2. Disconnect the negative battery cable.
3. Disconnect the positive battery cable.
4. Unhook the battery hold down strap.
5. Lift out the battery.
6. Lift out the battery tray.
7. Remove the four bolts that secure the seat bracket and rear fenders to the frame using a 1/2" wrench. See Figure 11-42.

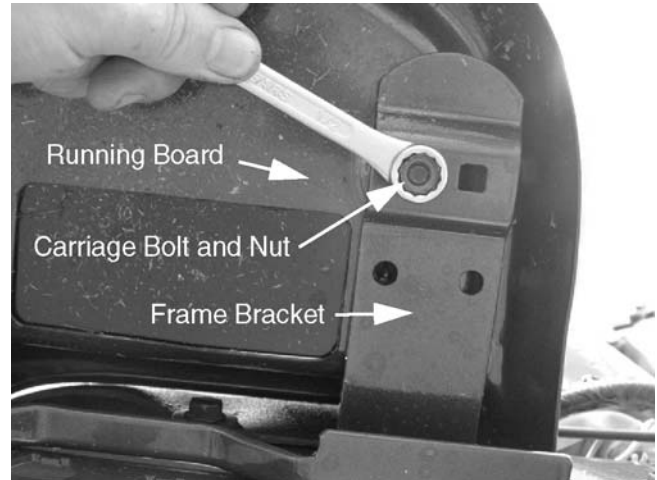


**Figure 11-42**

**➡ NOTE**

The seat can be removed from the seat bracket by releasing the clip, and sliding the seat rearward.

8. Remove the nuts from the carriage bolts that secure the front corner of each running board to frame brackets using a 1/2" wrench. See Figure 11-43.



**Figure 11-43**

**➡ NOTE**

Thumb pressure may be required on top of the foot pad to hold the carriage bolt in position.

9. Unclip the cover in front of the control handle slots. See Figure 11-44.



**Figure 11-44**

10. Remove the hex nut and carriage bolt that hold the top of the IZT control handle to the IZT control lever. Use a 1/2" wrench.
11. Insert a 1/2" socket on an extension through the access hole in the side of the dash panel to remove the nuts that hold the base of the IZT control handle to the IZT control lever. See Figure 11-45.



**Figure 11-45**

**➡ NOTE**

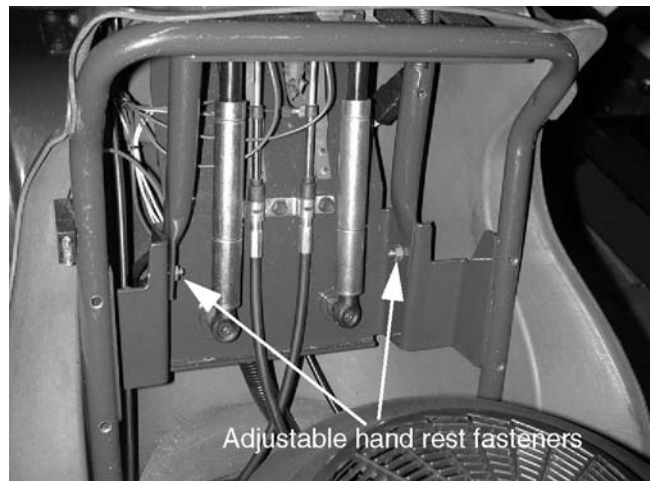
A magnet, or a piece of tape in the socket will make removal and installation of the nut much easier. See Figure 11-46.



**Figure 11-46**

12. Remove each IZT control handle.
13. Loosen and remove the two shoulder bolts that secures the adjustable hand rest to the dash

support hoop using a 7/16" and a 5/8" wrench. See Figure 11-47.



**Figure 11-47**

14. Lift the adjustable hand rest slightly. See Figure 11-48.



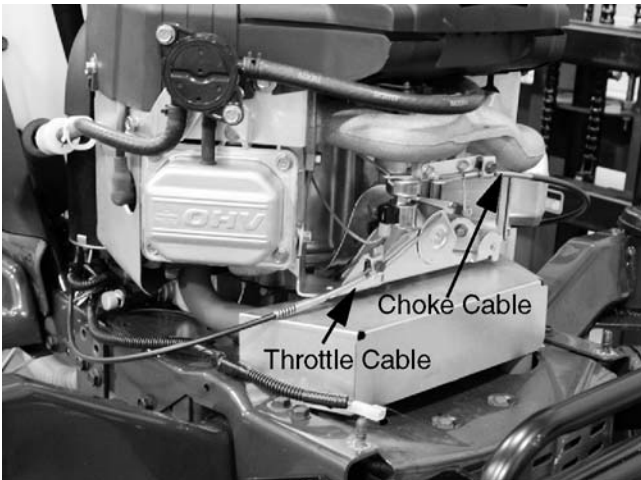
**Figure 11-48**

15. Pull the hand rest adjustment bail forward. See Figure 11-49.



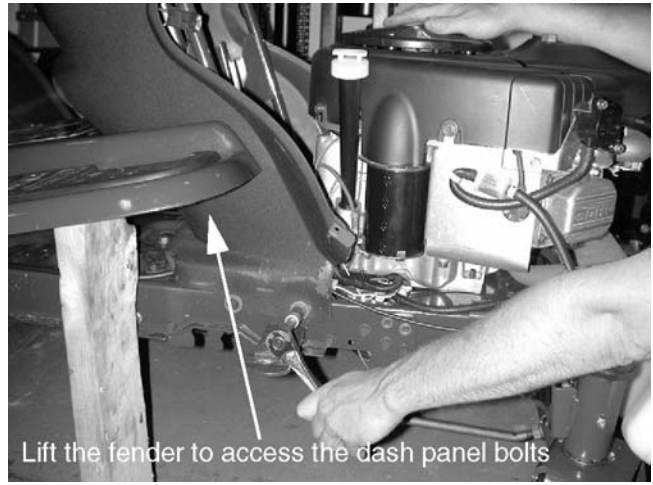
**Figure 11-49**

16. Lift the adjustable hand rest completely out of the dash panel.
17. Mark the positions of the choke and the throttle cables at the engine using paint or a magic marker. See Figure 11-50.



**Figure 11-50**

18. Disconnect both cables from the engine.
19. Lift the rear fenders straight up to clear the seat springs.
20. Slide the rear fenders back, and prop up the running boards. See Figure 11-51.



Lift the fender to access the dash panel bolts

**Figure 11-51**

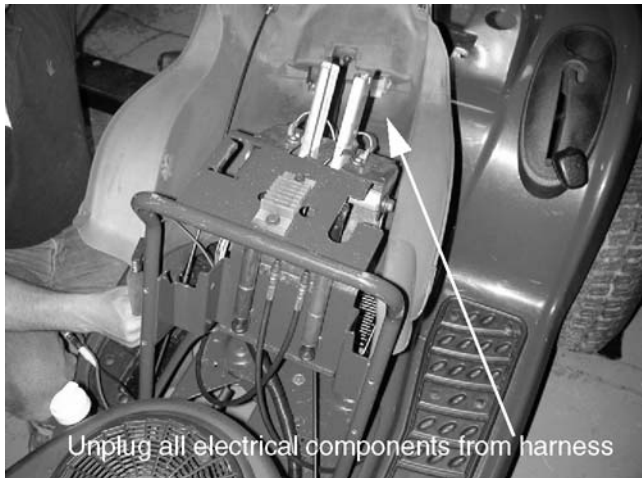
21. Use a 1/2" wrench to unbolt the base of the dash panel from the frame. See Figure 11-52.



**Figure 11-52**

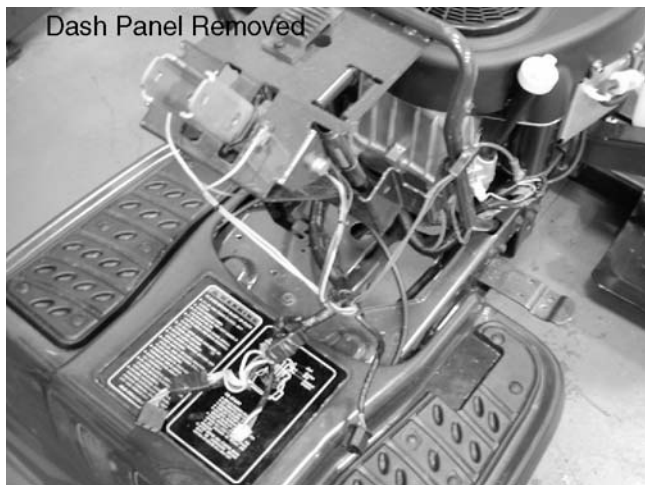
22. Lift the dash panel up and back slightly, to provide easier arm access.
23. Unplug the key switch, hour meter, and PTO switch. See Figure 11-53.





**Figure 11-53**

24. Remove the dash panel from the tractor. See Figure 11-54.

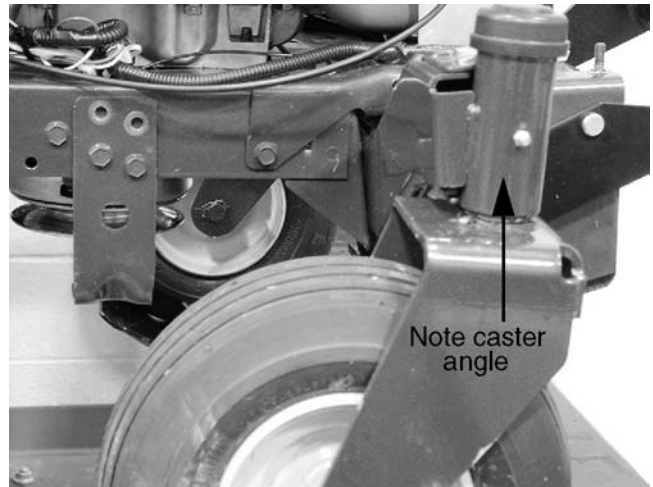


**Figure 11-54**

25. Assemble in reverse order as above.

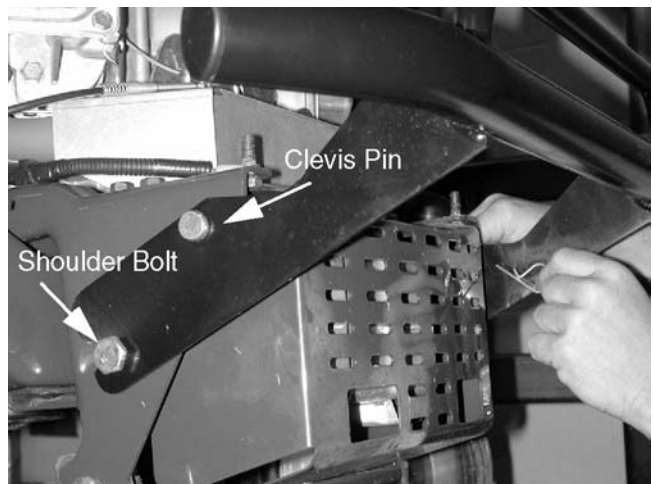
### Front Axle:

**IMPORTANT:** The shaft that the caster wheel swivels on must angle back in order to track correctly. Pay attention to the position of the tube: it goes ahead of the pivot bar. See Figure 11-55.



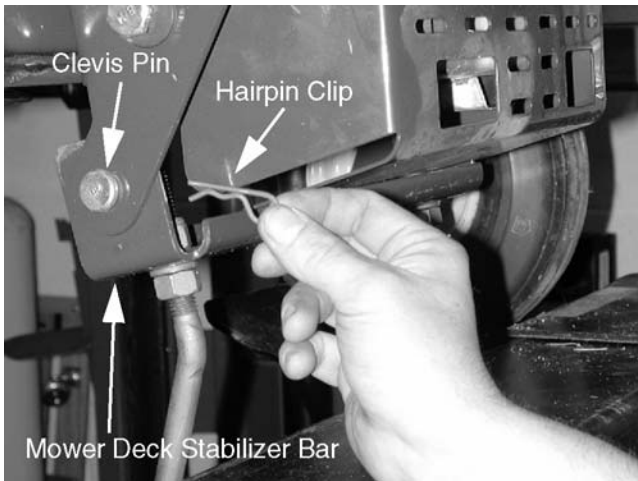
**Figure 11-55**

1. Prior to performing this section, perform hood removal.
2. Lift the front of the tractor and support the frame from below.
3. Remove the hairpin clips that retain the front bumper clevis pins.
4. Support the bumper with one hand, and remove the clevis pins with the other. See Figure 11-56.



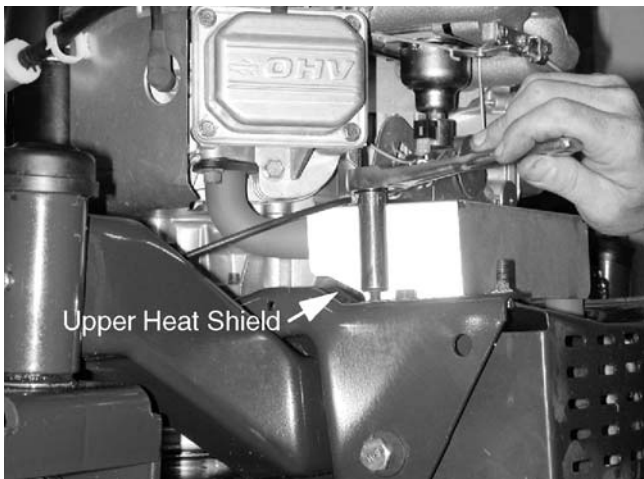
**Figure 11-56**

5. Pull the bumper up and forward to remove it from the shoulder bolts.
6. Remove the hairpin clips and clevis pins that secure the mower deck stabilizer bar to the frame. See Figure 11-57.



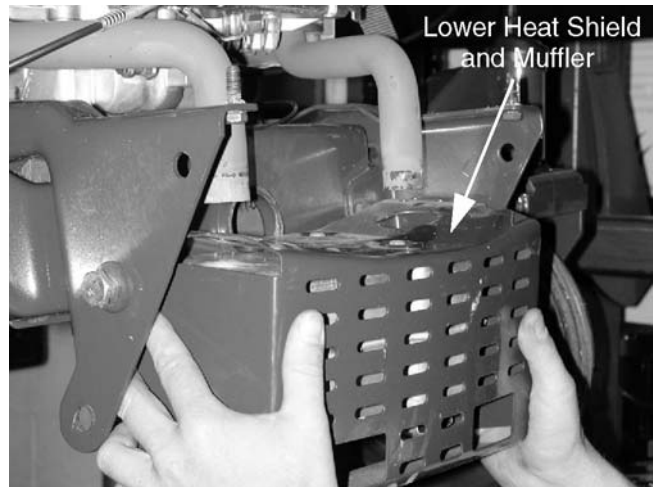
**Figure 11-57**

7. Remove the stabilizer bar and set it aside.
8. Unbolt the upper heat shield using a 1/2" wrench. See Figure 11-58.



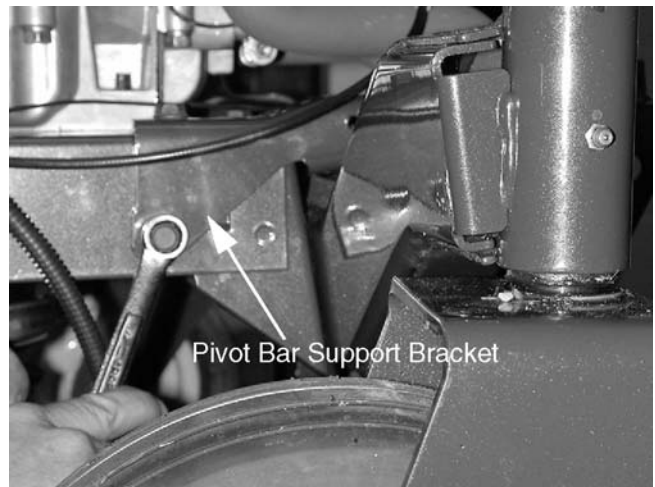
**Figure 11-58**

9. Remove the upper heat shield.
10. Unbolt the lower heat shield and muffler as a unit using a 1/2" wrench. See Figure 11-59.



**Figure 11-59**

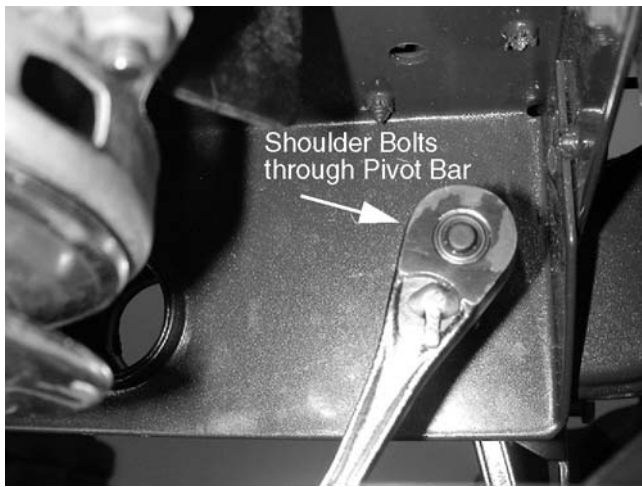
11. Remove the muffler by sliding it down and off the exhaust pipes.
12. Remove the self tapping screws that secure each pivot bar support bracket to the side of the frame.
13. Remove the longer bolts that attach each bracket to the top of the frame using a 1/2" wrench. See Figure 11-60.



**Figure 11-60**

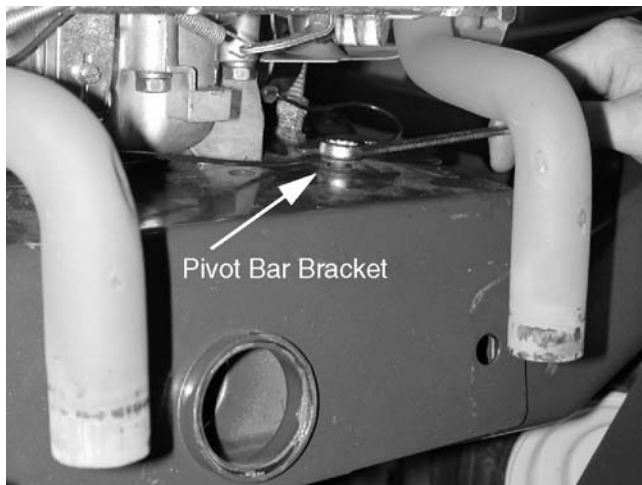
14. Remove the shoulder bolts that pass through the pivot bar bracket, pivot bar, and frame using a 9/16" and 3/4" wrench. See Figure 11-61.





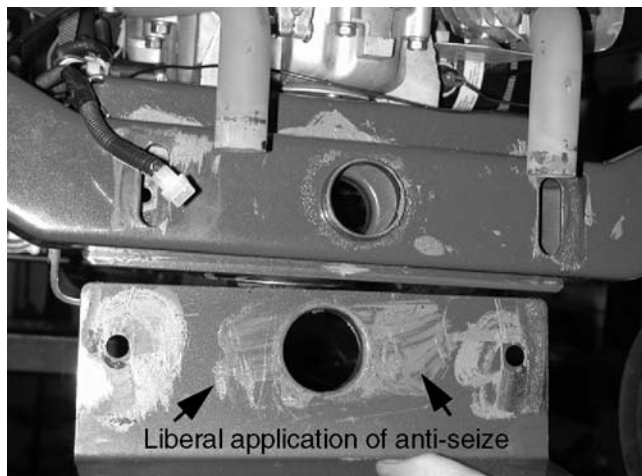
**Figure 11-61**

15. Unbolt the pivot bar bracket from the top of the frame using a 1/2" wrench. See Figure 11-62.



**Figure 11-62**

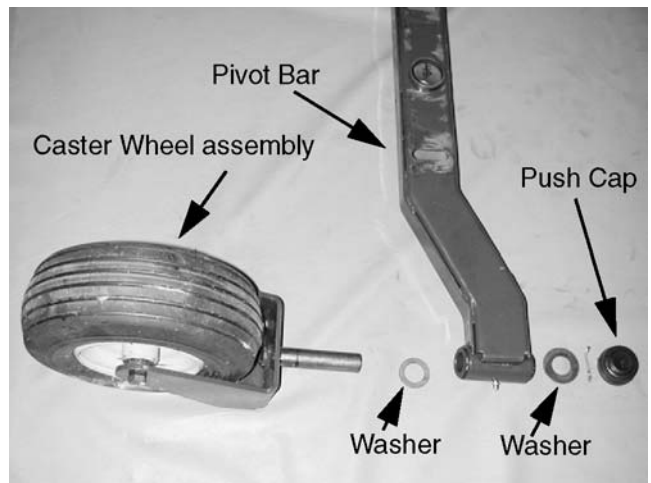
16. Lift the pivot bar off of the round shoulder at the front of the frame. See Figure 11-63.



**Figure 11-63**

17. Reinstall in reverse order.

## Caster Wheels



**Figure 11-64**

### ➔ NOTE

Caster wheels may be serviced without removing the pivot bar from the tractor.

1. Lift the tractor to allow the swivel shaft on the caster wheel to be removed from the tube at the end of the pivot bar.
2. Support the tractor securely.
3. Snap the dust cover off the top of the caster wheel swivel shaft.
4. Support the wheel to be removed.
5. Remove the cotter pin from the hole above the tube at the end of the pivot bar.
6. Remove the top (large) thrust washer.
7. Lower the swivel shaft out of the tube.
8. The lower thrust washer will remain on the swivel shaft, be careful not to lose it.
9. Drive the nylon bushings out of the tubes, if they are to be replaced.
10. Reassemble in reverse order above. Replace the used cotter pin with a new one.

# CUTTING DECKS

## Operation \* Problems \* Solutions

### WALK-BEHINDS AND LAWN AND GARDEN TRACTORS THE FOLLOWING CONDITIONS CAN AFFECT THE QUALITY OF CUTTING GRASS

**TIRE PRESSURE VARIATION:** The air pressure should be equal on both front and rear tires, approximately 12-13 lbs. air pressure regardless of the size tire on lawn and garden tractors.

**DECK WHEELS INCORRECTLY SET:** The deck wheels should be set evenly so that the pitch of the cutting blades will not be affected. If any difference is required for a better cut on some walk-behind mowers, the front height adjuster can be one position lower to assure that you are cutting with the front of the blade. If the deck is slightly lower in the rear you will tend to cut the grass at the rear of the mower. This causes the grass to be thrown to the rear wheels and causes a rough or irregular cut.

**DECK WHEEL ADJUSTMENT:** The deck wheels on all lawn and garden tractors should be adjusted so they will be 1/2" to 1" off the ground at all times. All cutting decks are floating so that they can cut evenly over the ground. The angle from front to rear is built into the assembly on lawn tractors. Check to be certain the distance from the bottom edge of the deck to the ground is the same on both sides of the deck. If it is not, adjust the links on the left side of the unit. The linkage is adjustable on garden tractors. After you have leveled the deck to the ground, you must adjust the linkage up 1/2" to 1" above the ground.

Check to be certain the front of the deck is 1/4" to 3/8" lower in the front of the deck than from the rear of the deck. If it is not, adjust the two front links to obtain this distance. This is of most importance. You must keep in mind that if the deck is riding on the ground and you want to make a turn with the tractor the cutting deck still wants to travel straight if the wheels are on the ground and then as you turn the cutting deck will be dragged sideways. This then damages the wheels or the rollers.

The deck doesn't turn because there is no differential on the rear axle assembly. This condition will also damage or bend the deck hangers

or deck links. From then on till the problems are corrected the quality of cut is affected. When the wheels are set to run on the ground, the deck drive belt is also subjected to excessive load conditions. This causes the belt to become very tight and then loose repeatedly during the course of mowing and again this condition is magnified when making turns, causing premature wearing on the belt. Bent or uneven deck links can cause cutting problems. Deck links should move freely and not bind against the frame of the tractor or other component parts.

**CUTTING BLADES:** First of all the blades must be the correct part number for the mower and original equipment style, according to the owner's manual. The blade part number is stamped and is found stamped into the back side of the blade. MTD blades are tempered and designed only to bend on impact and not to break. They are tested for this properly and upon impact with an object. Nothing can come off the mower. The only time a blade breaks is when first it is bent and the person operating the mower chooses not to do anything about it. With the blade now vibrating it will crack at the mounting bolt holes. You may vision this as to when you take a piece of metal and bend it back and forth. Many times it will break in two pieces. This condition on a mower blade can easily be detected by looking at the crack. The first part of the crack will be rusting and the final stage of breaking will be shining and not rusted.

The blade adapter will often also show evidence as either being cracked or one of the mounting ears bent upward. Blades are designed to be high lift, therefore meaning that they are made with a raised area, behind the cutting tips which create a lifting action, pulling the grass up to the blade. The proper lift is more important to the cutting quality than even a sharp edge. The blades must be run at full throttle position on the mower. To assure this, the engine should be checked and running at

3400 to 3600 RPM. This should be checked with a tachometer by a qualified dealer.

The blades running at the proper RPM develop a vacuum lift action. This is created by a combination of things, mainly a deck designed with baffles in the front and rear of the deck. The deck depth and controlled flow design helps to develop a deep vacuum action lifting the grass for cleaner, sharper cutting and efficient discharge of the grass out the side or to the rear for bagging. This then brings us to understand the importance of discharging the grass. To accomplish this most effectively a full baffled deck housing is needed. That is also why the most effective decks for mulching are designed like a donut. The depth is important because after the grass is cut it must rise into the dome of the housing and as it falls to the ground the grass is cut many more times by the inner angles and edges of a special mulching blade.

Most of our walk behind mowers are designed to be what we call three-in-one mowers, meaning that they will mulch, side-discharge and side or rear bag grass. Blades must be properly sharpened, following the original angle and then checked for balance. If the blades are dull and nicked on the cutting edge this will tend to tear the grass rather than cut it. Mulching blades are more critical and most often it would be better to replace the blade rather than trying to sharpen the varying angles and possibly lose its effectiveness. If blades are in question, measure from a level surface to the blade tip, using a rule or tape measure. The blade should be checked and then rotated to the other end 90 degrees. The measurements between the blades should be the same and no more than 3/16" height difference when the blades are tip to tip. If more than the 3/16" is discovered and the deck is hanging properly from the tractor, the blades should be removed and checked for straightness.

The sharpened edges should lie flat against the surface plate. If they do not, it is possible the blade is bent or warped. The blade can be placed in a vise and straightened or replaced. IF the edge of the blades are found to be straight, it is then possible that the spindles or spindle area in the deck is bent or warped from hitting an object, root or curb. Each blade spindle can be checked and removed from the deck and placed in a vise by the bearing housings. By rotating the blade by hand a bent spindle can be detected by wobble. If this is found,

the spindle should be replaced. Often this is checked when it is felt that bearings have worn out prematurely. Bearings and spindles often take damaging shocks that the user is now aware of, or quickly forgets that a few roots etc., have been hit.

**MISSILE DEFLECTORS:** All of our mower decks are equipped with a missile deflector to direct the flow of grass out the side of the deck at a safe angle and mowers should only be operated with the deflector in the down position. During our testing procedures we inject steel balls and nails under the deck while the mower is running so that we can determine the angle that these objects will be discharged. The regulated height that any item can come out is no higher than the knee.

Decks should always have this deflector properly installed on the mower housing. If for some reason that this deflector is off the mower during the warranty servicing, a claim can be submitted for replacement. A mower without a deflector can project STONES from the driveway, and the NAILS that fell into the lawn when the roofer was installing the new roof and of course, no one could find them, but the lawn mower does find them when you least expect.

**DECK BELT GUARDS:** Belt guards must be properly adjusted and kept in place. The belt guards (hex bolts) on the engine pulley and belt guards on the deck pulleys should have a minimum of 1/8" clearance. Belt guards which are rubbing the pulleys and/or belts can cause the belt to be subjected to excessive heat. The possibility of a belt rolling over is greatly increased when this type of condition exists. The engine pulley and the deck pulleys should be free of any nicks or dents and the pulley sheaves edges should be smooth and free of burrs.

It is also important to then understand that these belt guards are not only to keep the belt on the pulley, but that they are also needed so that the belts trap-out against them. When the belt is disengaged, the belts then are prevented from continuing to travel. Understanding this, it is then easy to understand the importance of the proper belt size and construction. All MTD belts are constructed according to engineered drawings for the proper performance, not by chance to size.

To begin a repair on any mower the first thing to determine is, does it have the original type belts installed on it? If it does not, that is the place to start your repair. The belts must be to the manufacturers specifications. The results of the wrong belt on a deck can also cause poor cutting quality because the belt could be slipping on the blade spindle pulley and this can cause too slow of a blade speed. Grass in

the spring has a high moisture content and sometimes it is just too wet. This too can affect the quality of cut. Grass should be relatively dry when cutting and a moderate ground speed be selected. Use the transmission to select the speed. Do not change the throttle control from the full throttle position. For further information on individual decks, check the Technical Service Handbook #770-8640L.

## CUTTING DECKS

12-1.1 Following is a list of cutting problems, which may be encountered with twin-blade mowers, and possible solutions.

1. Uncut strip of grass. Only the tips of the blades cut so they must be sharp clear to the end. Sharpen the blades. Dull blades tear the grass rather than cut it.
2. Engine speed too slow. The engine should be operated at full throttle regulated by O.P.E.I. on mowers where blade is fastened directly to crankshaft. On riding mowers the cutting blade shaft is driven through the use of a belt and pulleys, or a gear box, and may not rotate at the same speed as the engine.
3. Ground speed too fast. Use the transmission to select a slower ground speed.
4. Blades not even with each other.
  - a. There should be no more than 3/16 inch difference between the blades. Check for a bent blade or spindles; if not bent, the deck may be warped and should be replaced.
  - b. Check the blade alignment by measuring from the ground (or flat surface) to tip of blade, rotate blade and check each end. See Figure 12-1.

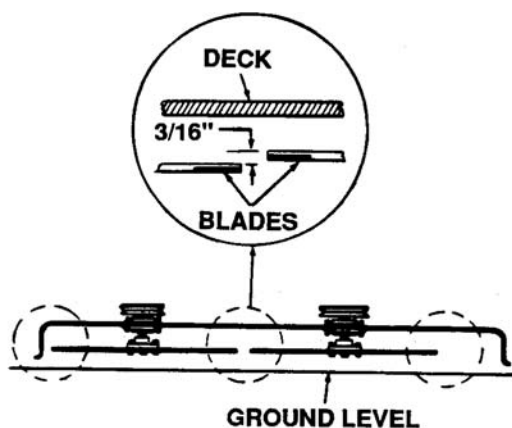
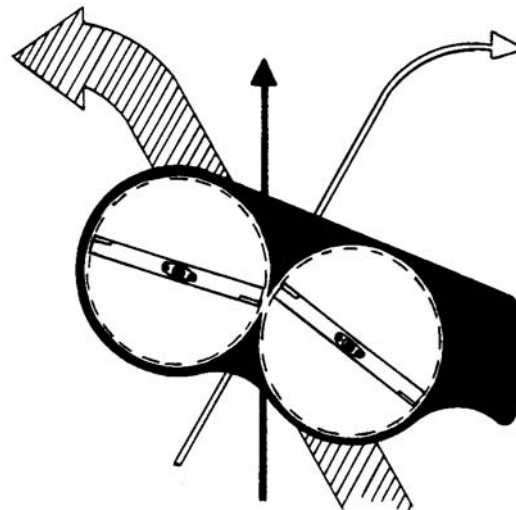


Figure 12-1. Blade Alignment

5. Turning to the right leaves small uncut strips of grass at end of lawn. To prevent this, make left hand turns when mowing or go back and trim when finished. See Figure 12-2.



- SHOWS LH TURN AND APPROXIMATE OVERLAP
- SHOWS STRAIGHT MOWING AND APPROXIMATE OVERLAP
- SHOWS RH TURN AND APPROXIMATE UN CUT STRIP

Figure 12-2. Turning Procedure

6. Short blade. Blades are sometimes manufactured short or sharpened too much on twin-blade units, replace.
7. Uneven cut.
  - a. Air pressure should be equal on both front and rear tires.
  - b. The deck wheels should be set evenly so the pitch of the cutting deck from side to side will not be affected.
  - c. Deck links should move freely and not bind against the frame of the tractor or other component parts. Links must also be the correct length.

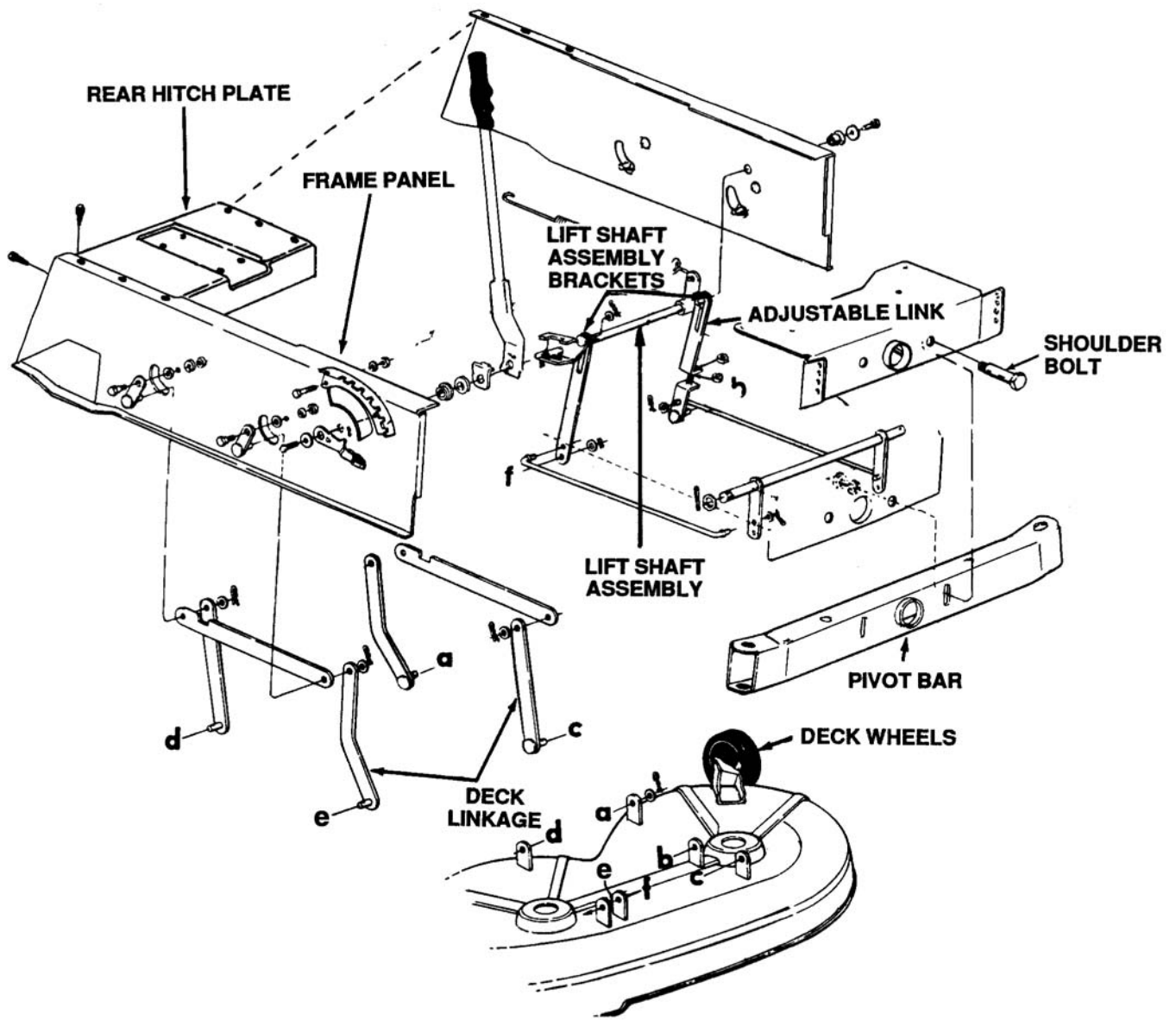


Figure 12-3. Lift Shaft Assembly

- d. Brackets on lift shaft must be welded in line with each other. If they are not, the deck will be higher on one side than the other. If this is encountered the lift shaft should be replaced or an adjustable link which is now available can be used to correct the problem. Order part number 16065. See Figure 12-3
- e. The pivot bar should move freely. If the bolts are too tight, hung up, damaged or bent, the tractor could be tilted to one side. Some units have an adjustable link to help level the deck. An adjustable link can be added to models by ordering link, part number 16065.
- f. The welded brackets on the stabilizer shaft should be straight and even. This can be checked by removing it from the unit and laying it on a flat surface.
- g. Frame alignment is very important. If the entire tractor is leaning to one side it was probably out of position on the assembly fixture. This is usually noticed because the deck will hang higher on one side and will result in an uneven cut. This condition can be corrected as follows:
  - (1) Loosen the 12 self-tapping screws which secure the right and left hand side frame panels to the rear hitch plate.
  - (2) Push the frame of the tractor by hand until the tractor is level.
  - (3) Tighten the self-tapping screws.

## 12-2. CUTTING DECK PROBLEMS AND SOLUTIONS.

12-2.1 Following is a list of cutting deck problems and possible solutions.

- 1. Noticeable vibration. If a vibration is noticeable, a bent spindle can be detected by using a dial indicator.
- 2. Warped deck. If this is suspected, remove deck and place on a flat surface. Measure blade tip to surface of work bench at four points around the blade spindle mounting area.
- 3. Deck wheels out of adjustment. If cutting deck is equipped with wheels, make sure they are

always adjusted from 1/4 to 1/2 inch off the ground after you determine the height the grass is to be cut. If wheels are not on deck originally, wheels should not at any time be added.

- 4. Belt slippage. Belt slippage can cause uneven cut. The factory always recommends the use of original equipment manufacturer (OEM) V-belt only. They are of special construction involving the type of cord and cord location and fractional length. V-belts other than OEM generally will only provide temporary service. For best belt cutting performance, use only approved belts.
- 5. Strip or uneven cut. A strip or uneven cut caused by belt slippage can occur if the cutting deck has hit something and twisted the stabilizer links out of position. Links hanging from a stabilizer bar (whether front or rear mounted) must be in line. To check, remove the stabilizer bar and lay it on the work bench and see if it lies flat. If one link is twisted it can be brought back into alignment by placing it in a vise and twisting the other welded link back in line. If this cannot be done, replace stabilizer bar.
- 6. Deck not level.
  - a. On most riders and tractors the variance in the cutting deck can be brought into alignment with the adjustable deck links or an adjuster on the lift shaft handle assembly on the 600 Series riders prior to 1990.
  - b. For 1990 and 1991 38-inch decks only. If uneven cut is experienced, attach the rear stabilizer plate to the bottom hole in the links welded to the stabilizer shaft assembly. Reconnect the spring which was in lower hole to the stabilizer shaft assembly.
- 7. Belt fails to engage/disengage. The disengagement rod must be adjusted before operating the lawn tractor to be sure belt engages and disengages at the first notch on detent bracket. See Figure 12-4.
- 8. Front axle pivot binds. Always make sure that the pivot bar to which the front axles are attached, pivots freely. Grease if necessary.
- 9. Uneven ride or difficult steering. Observe the brand name on the tires and make sure all tires (or at least the two front and two back pairs) are the same name and size. Some tires inflate

differently when manufacturer is different, even though size shown on tire may be correct.

12-3. **MODEL 793 30-INCH REAR DISCHARGE MOWING DECK FOR 500 SERIES RIDING MOWER.**

12-3.1 This new deck is used on the 502 through 506 series riders. This deck cuts a 30 inch swath and ejects the grass through the rear discharge chute directly between the rear wheels of the rider. It can be used with rear grass catcher kit, part number 190-038. See Figure 12-5.

12-3.2 As with the 30 inch side discharge deck, it is important for the brake cable to be adjusted

properly. It should be adjusted so that the brake pad on the blade brake bracket assembly just clears the deck pulley when the blade is in the engaged position. If it is adjusted so that it pulls too far away from the pulley, the brake cable will prevent the deck from traveling forward completely to fully engage the deck belt. This will result in the deck belt slipping on the pulley and a damaged V-belt.

**→ NOTE**

If the discharge chute is mounted improperly, the safety switch located on the deck will not allow the engine to operate.

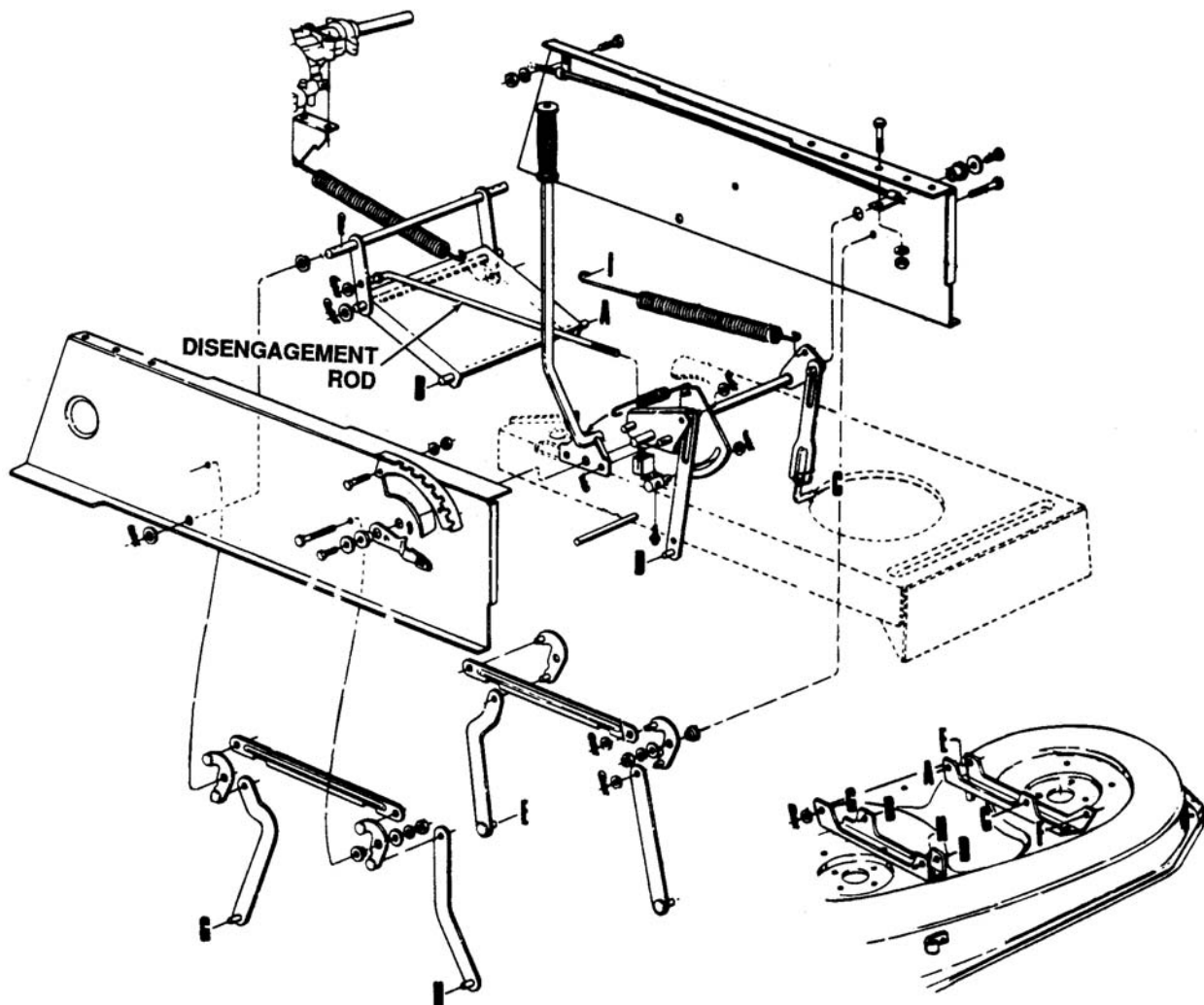


Figure 12-4. Location of Disengagement Rod

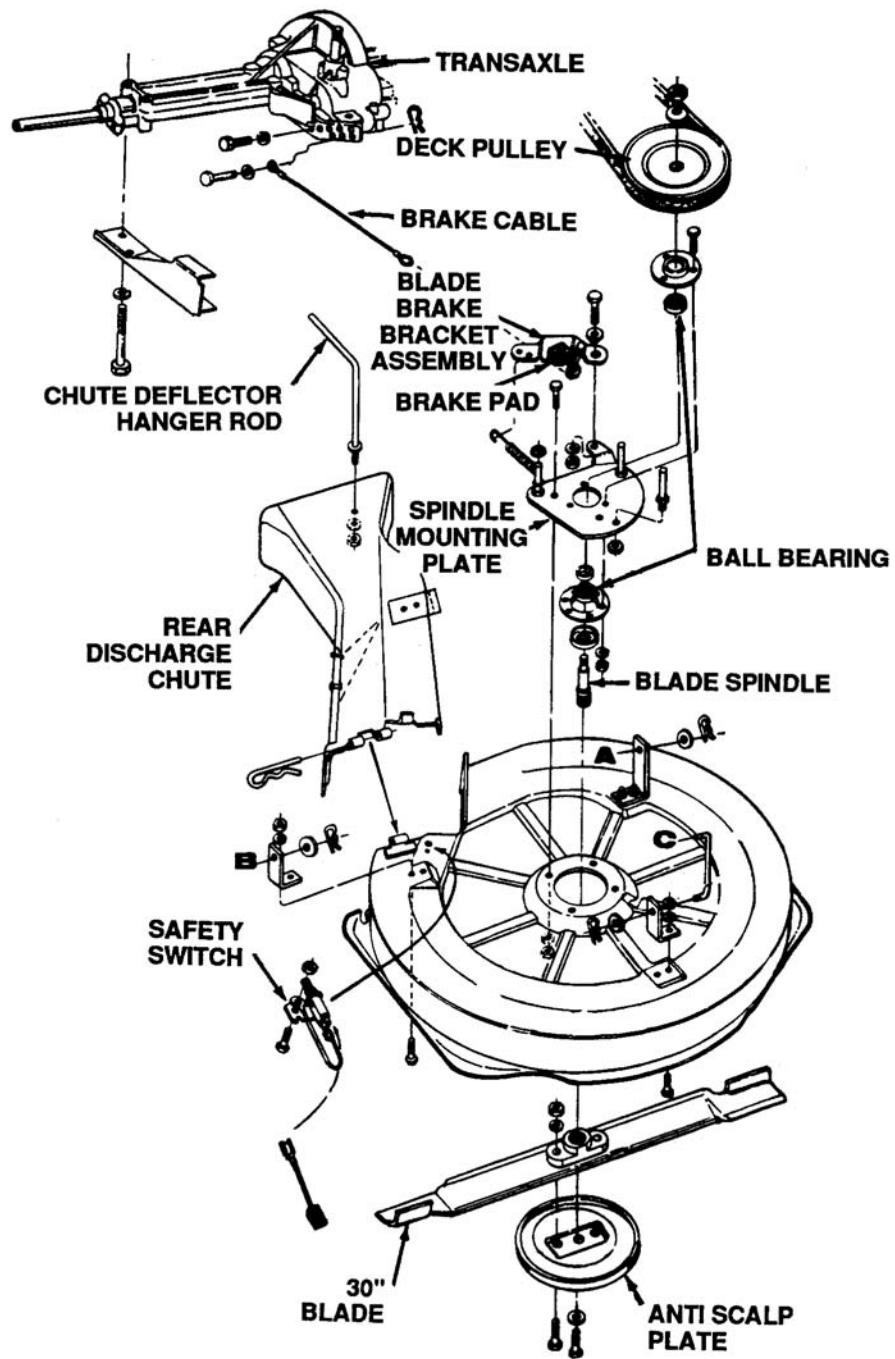


Figure 12-5. Model 793 30-Inch Rear Discharge Deck



**12-4. MODEL 796 30-INCH SIDE DISCHARGE MOWING DECK FOR 500 SERIES RIDING MOWER PRIOR TO 1990.**

12-4.1 The deck is attached to the rider in the same manner as the 30-inch rear discharge deck and the procedure for removing the deck is also the same. See Figure 12-6.

12-4.2 **Blade Brake Adjustment.** Adjust brake as follows:

1. Disconnect the brake cable from the lower inside belt guard on the rider by removing the hairpin cotter, flat washer and clevis pin. See Figure 12-7.
2. Lower the deck to its lowest position. Place the blade engagement lever in the disengaged position.

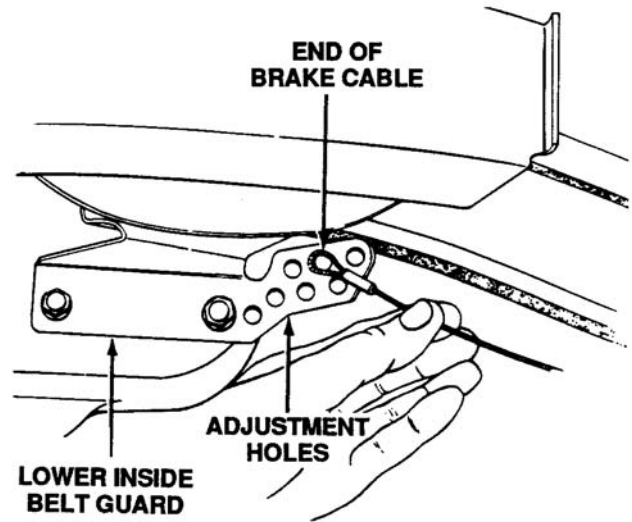


Figure 12-7. Adjusting Brake Cable

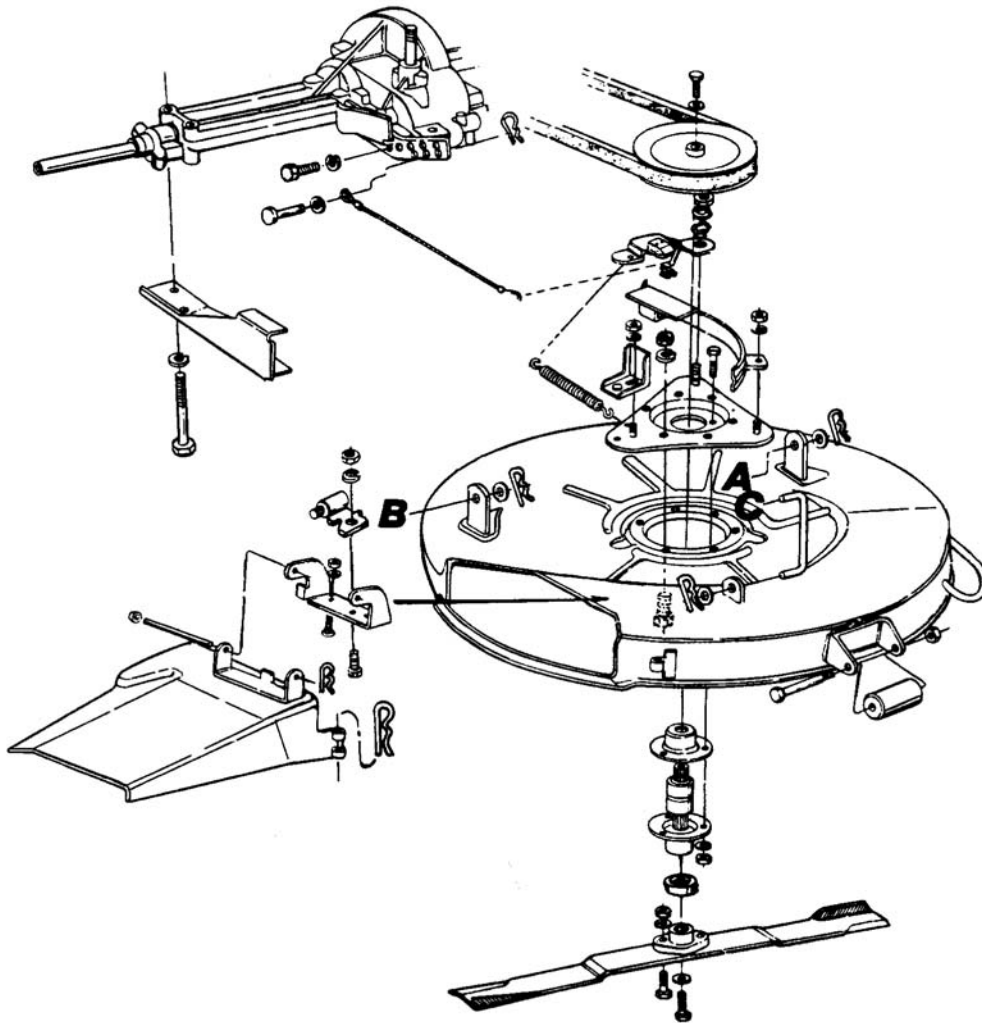


Figure 12-6. Model 796 30-Inch Side Discharge Deck Prior to 1990

3. Pull the brake cable so there is no slack in the cable. Do not put tension on the cable. Select the hole in the lower inside belt guard which aligns with the end of the cable. Move the end of the brake cable forward to the next hole in the belt guard (which will give a small amount of slack in the cable) and reassemble.

**12-5. 30-INCH REAR DISCHARGE MOWER DECK FOR 500 SERIES RIDING MOWER 1990 AND LATER.**

- 12-5.1 This deck was redesigned to use the 063 twin bag grasscatcher and 435 adapter package and is also interchangeable with units produced prior to 1990. See Figure 12-8.

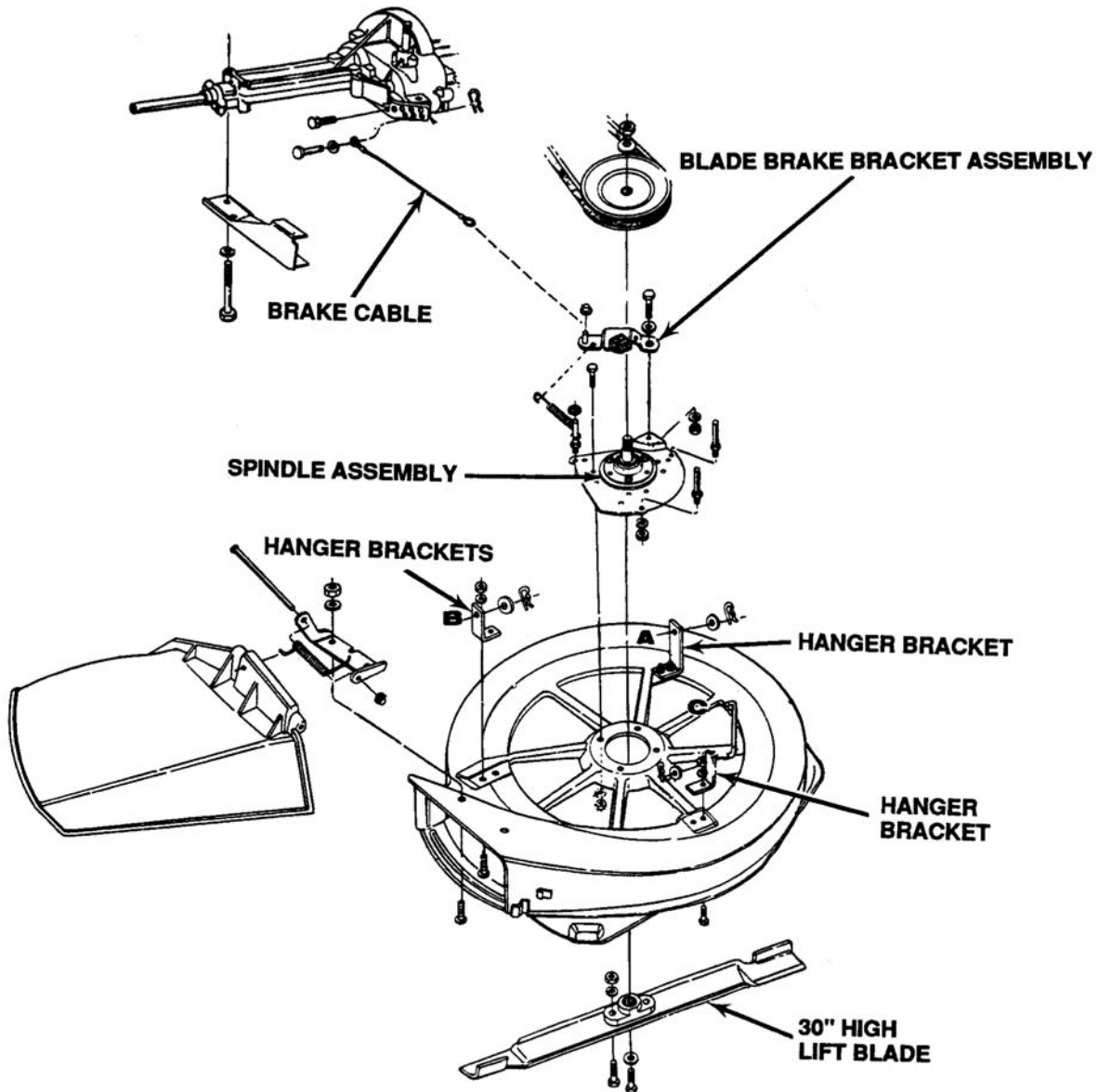


Figure 12-8. Rear Discharge Deck 1990 and Later

## 12-5.2 Removing Deck Models 793 and 796.

Remove deck as follows:



### WARNING

Disconnect the spark plug wire and ground it against the engine.

1. Move the blade engagement lever to the disengaged position.
2. Remove one hex bolt and lock washer at the front of lower outside belt guard. A 1/2 inch wrench is required. See Figure 12-9.

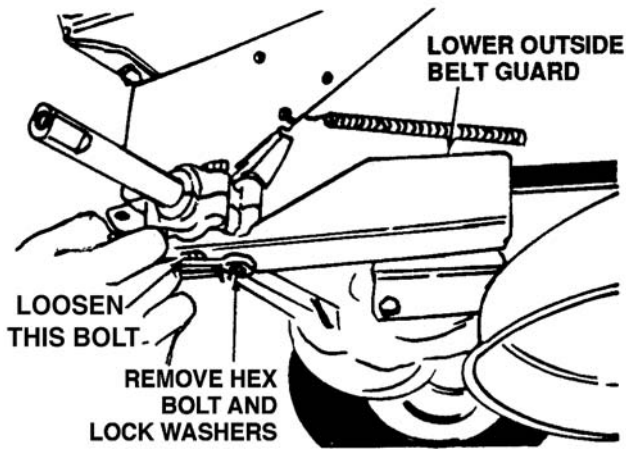


Figure 12-9. Removing Deck

3. Loosen (do not remove) the second bolt.



### NOTE

Rear wheel was removed for clarity only. It is not necessary to remove the wheel when removing the deck.

4. Pivot the lower outside belt guard out and away from the engine pulley. See Figure 12-10.
5. Disconnect the brake cable from the lower inside belt guard by removing the hairpin cotter, clevis pin and flat washer. See Figure 12-11.
6. Remove the front hex bolt from the lower inside belt guard.
7. Loosen the second bolt (do not remove), pivot the guard downward and slip the deck belt off the engine pulley. See Figure 12-12.

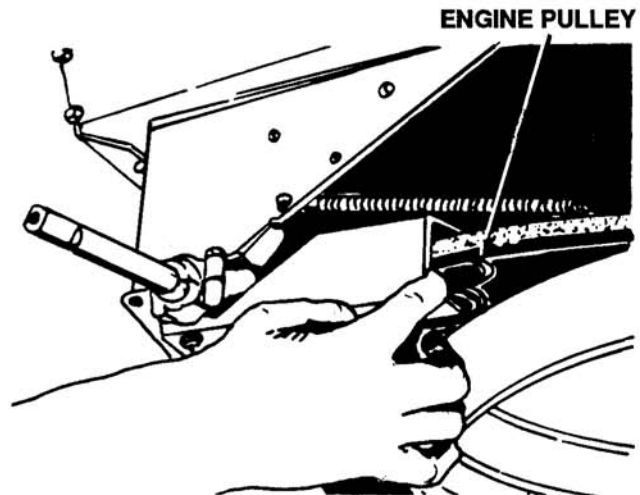


Figure 12-10. Pivoting Belt Guard Away From Engine Pulley

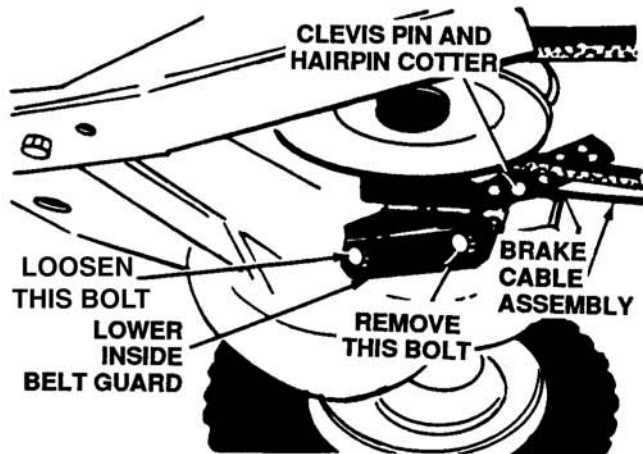


Figure 12-11. Disconnecting Brake Cable and Removing Hex Bolt

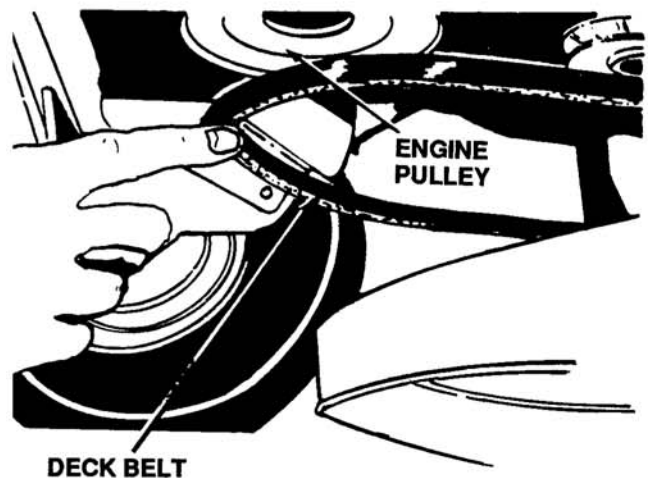


Figure 12-12. Removal of Deck Belt

- Remove the three hairpin clips and flat washers which hold the deck links to the rider. Two are located at the rear of the deck. One is located at the front of the deck. See Figure 12-13.

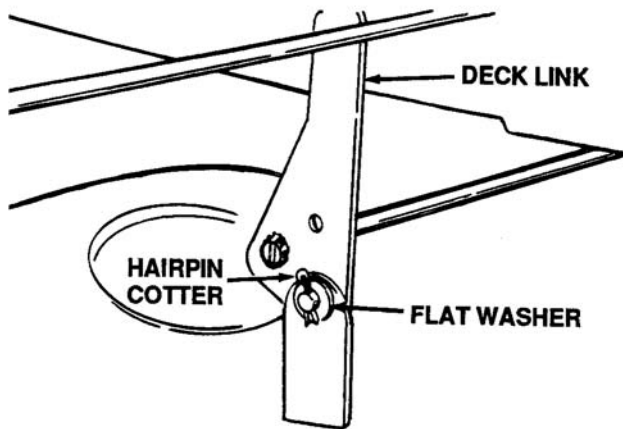


Figure 12-13. Location of Hairpin Clips

- Unplug the yellow wire from the chute safety switch. Pull the deck from under the rider. See Figure 12-14.

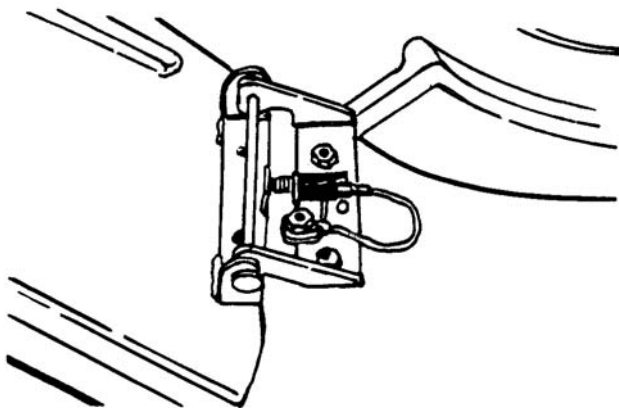


Figure 12-14. Location of Chute Safety Switch

- To reattach the deck, follow instructions in reverse order. Adjust the blade brake cable as instructed in the rider owner's manual.

### 12-5.3 Deck Drive Belt Removal.

- Remove the deck from the riding mower as described in previous section.
- Remove the three belt keeper studs on the deck. See Figure 12-15.

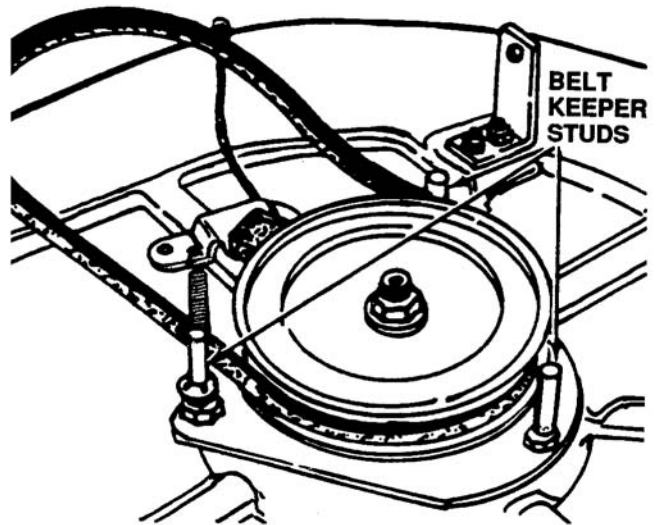


Figure 12-15. Removing Deck Drive Belt

- Remove and replace the deck drive belt.
- Loosen the belt keeper and work the belt past the keeper and onto the engine pulley, idler pulley, and top pulley on the idler bracket assembly.

### ➔ NOTE

Check tire pressure in all four tires before leveling the deck. Recommended tire pressure is 10 psi.

- If an uneven cut is obtained, the deck may be leveled. A deck adjustment rod is located on the right side of the unit. See Figure 12-16.

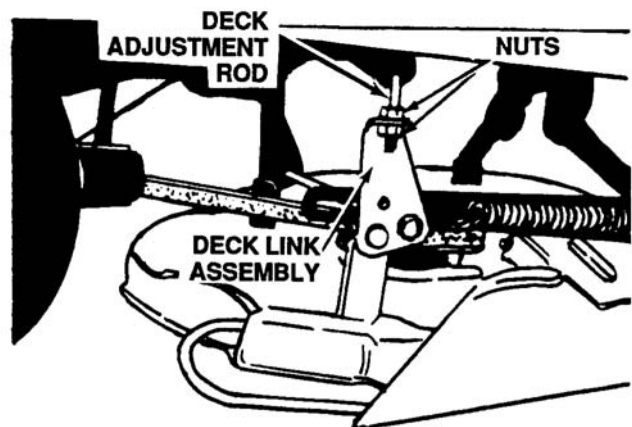


Figure 12-16. Deck Side-To-Side Leveling Adjustment

- To adjust the deck, loosen the two hex nuts at the right rear deck link assembly. Thread the

hex nuts up or down the deck adjustment rod as necessary. Retighten the hex nuts.

**12-5.5 Deck Front-To-Rear Pitch Adjustment.** The front of the deck should be approximately 1/4 to 3/8 inch lower than the rear of the deck. Adjust the pitch as follows:

1. Place the deck in the engaged position.
2. Remove the hairpin cotter and flat washer which hold the deck lift connecting rod to the front deck lift assembly. See Figure 12-17.

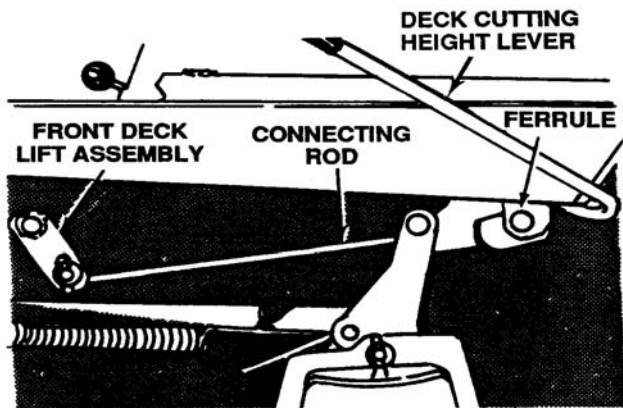


Figure 12-17. Deck Front-To-Rear Pitch Adjustment

3. Remove the connecting rod from the deck lift assembly and thread it in or out of the ferrule as necessary. Replace the rod.

**12-6. 32-INCH SIDE DISCHARGE MOWER DECK FOR 300 SERIES LAWN TRACTOR.**

12-6.1 This deck was specifically designed to complement the new tractors. The all new high vacuum 32-inch deck features a special vacuum lift blade which increases air flow for added vacuum action and better grass ejection and superior collection. See Figure 12-18, page 12-13.

12-6.2 In 1990 a new lift assembly was designed which includes positive engagement and disengagement, adjustable deck belt tension and a more stabilized deck. This deck will accept the 063 twin bag grasscatcher with 084 adapter package and is NOT interchangeable with 1989 and prior production.

**NOTE**

Sand blades are also offered, part number 742-0498 (2 per unit).

**12-6.3 Deck Belt Removal and Replacement.**

**WARNING**

Disconnect the spark plug wire and ground it against the engine. Block the wheels of the unit.

**NOTE**

When changing belts, a spring puller or other suitable tool is required to remove some of the springs. A spring puller, part number 732-0571, is available to assist in removal of springs.

Remove deck belt as follows:

1. Place the lift lever in the disengaged position.
2. Remove the hex bolts (belt keepers) from engine pulley belt guard. See Figure 12-19.

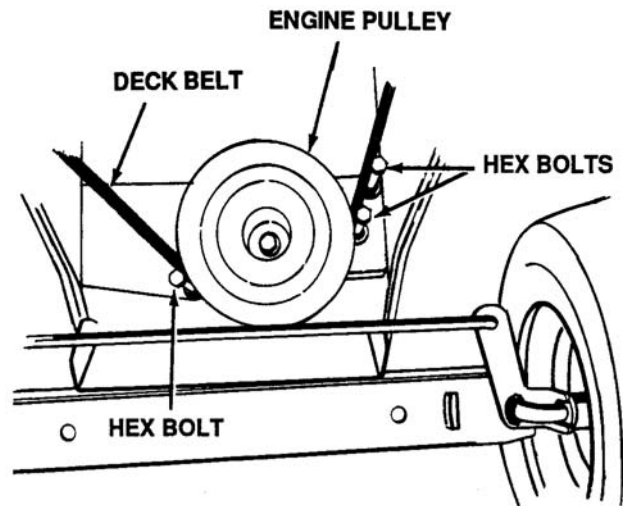


Figure 12-19. Location of Hex Bolts (Belt Keepers)

**NOTE**

Units may have either two or three hex bolts. When reassembling, make certain hex bolts are reassembled in the same locations from which they were removed, as shown in Figure 12-19.

3. Unhook the deck belt from the engine pulley.
4. Place the lift lever in the engaged (all the way forward) position.

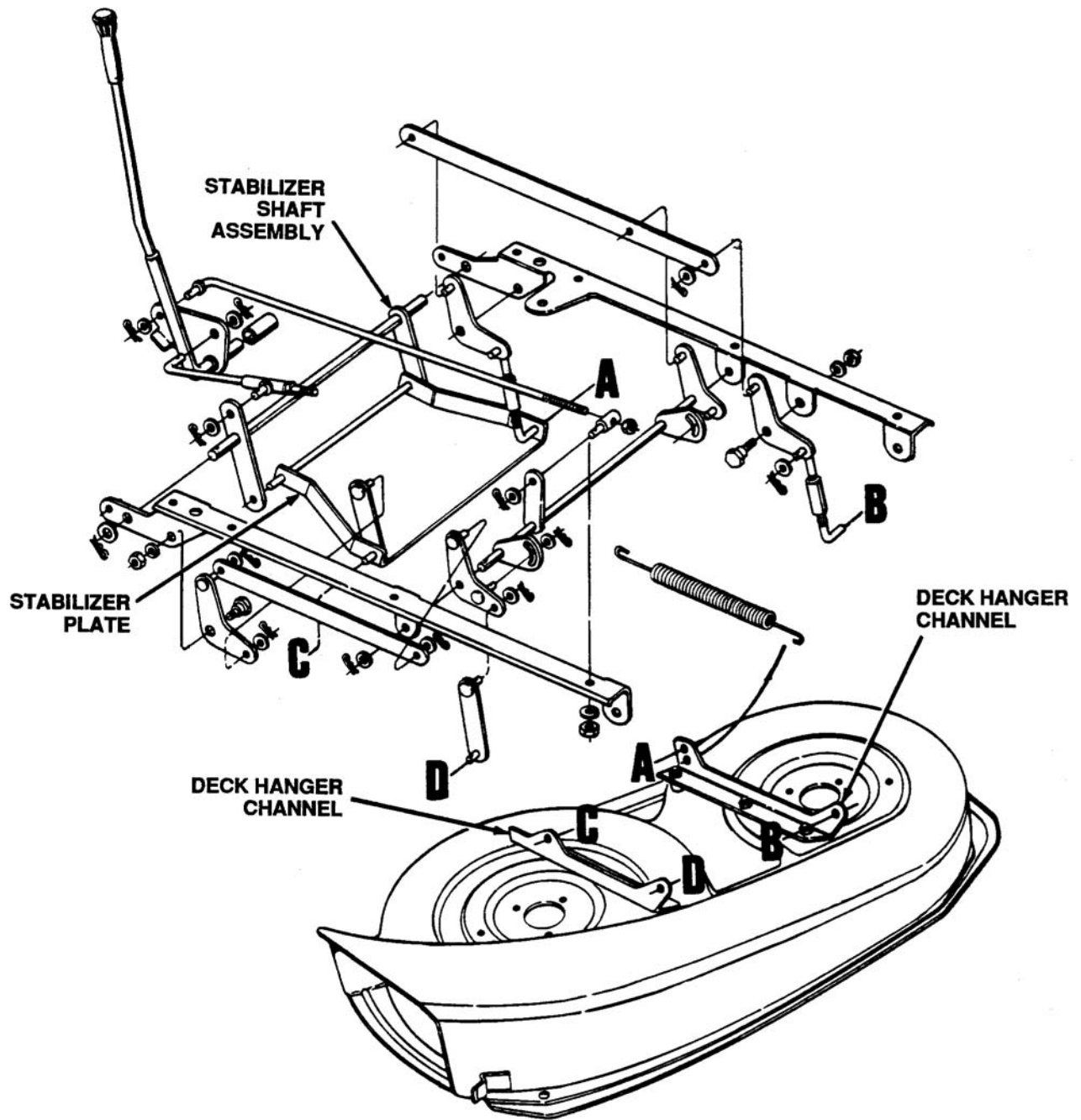


Figure 12-18. 32-Inch High Vacuum Deck

5. Disconnect the spring from the left rear deck bracket. See Figure 12-20.

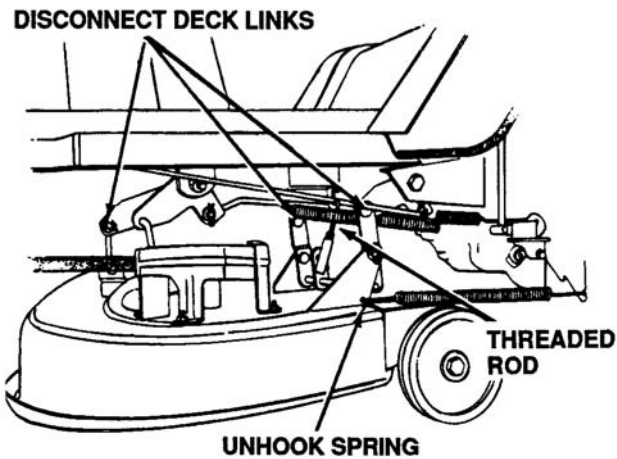


Figure 12-20. Removing Deck

6. Disconnect the two front deck links by removing the hairpin clips and flat washers.
7. Remove the belt guards at each deck pulley by removing the hex bolts, lock washers and hex nuts. See Figure 12-21.

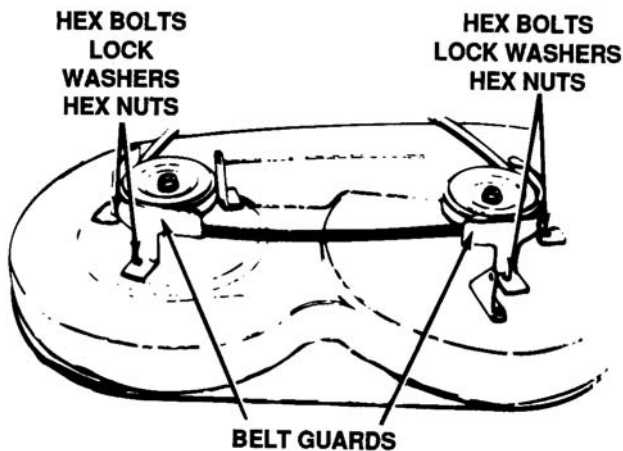


Figure 12-21. Belt Guards

8. Remove and replace the belt, following the instructions in reverse order.

**NOTE**

In mid 1988 production there was an engineering change made to the 32-inch deck drive belt, part number 754-0342. It has been changed to a 1 inch shorter belt, part number 754-0355. This made a more positive engagement at the highest cutting position. The deck must be readjusted for this new belt.

- 12-6.4 Production for 1988 has a new style switch and activating bracket. Check to be certain the switch activating bracket attached to the base of the lift lever is operating properly. See Figure 12-22.

1. With the lift lever in the disengaged position, the activating bracket should depress the plunger on the safety switch (located beneath the right hand running board).
2. With the lift lever in the engaged position, the plunger on the safety switch should be fully extended.
3. If the activating bracket requires adjustment, loosen the hex nut which secures it to the lift shaft assembly. Pivot the bracket so it activates the switch correctly with the lift lever in the disengaged position, and retighten the hex nut securely.

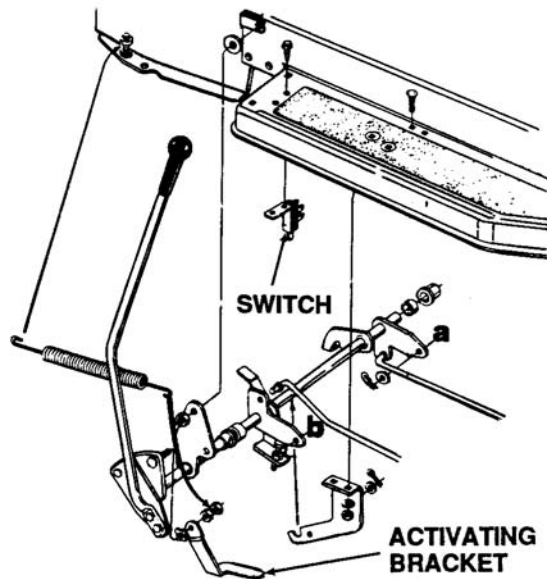


Figure 12-22. Location of Switch and Bracket

**NOTE**

It may be necessary to remove the right rear wheel to adjust the switch activating bracket.

**12-6.5 Deck Leveling Adjustment.**

1. Move the lift and disengagement lever forward (lower the cutting deck). Make certain the deck wheels (if so equipped) are not resting on the ground.

2. With unit on hard, level surface, measure the distance from the bottom edge of the center of the left side of deck to the ground. Measure the same distance just behind the chute area on the right side of the deck. Or, place the blades in a straight line, and measure the distance from the outside edge of the blade tips to the ground.
3. Disconnect the adjustable deck links from the deck lift pivot brackets on the left side of the unit by removing the hairpin clips and flat washers. See Figure 12-23.

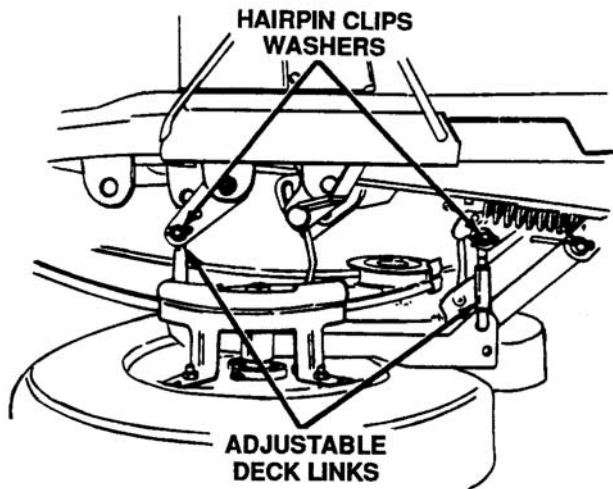


Figure 12-23. Location of Hairpin Clips, Washers and Deck Links

4. Thread the adjustable links in or out as necessary. Reassemble the links. Check the adjustment and readjust as necessary.

**12-6.6 Cutting Deck Engagement Adjustment.** The cutting deck engagement may be adjusted to make certain deck is disengaged when lift handle is in the disengaged position or to obtain more drive in the cutting positions. Correct adjustment as follows:

1. Place the lift handle in the highest cutting position (first notch down from disengaged position). The approximate adjustment is to have the lock nut on the threaded rod (above the rear of the deck) touching the end of the tubing. See Figure 12-24.

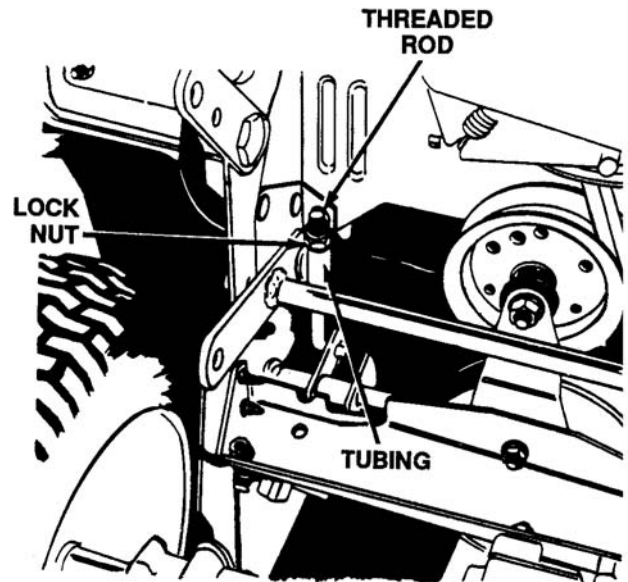


Figure 12-24. Location of Threaded Rod

2. Move the lock nut toward the tubing to start to disengage the deck earlier. Move the lock nut away from the tubing to obtain more drive in the cutting positions.



**WARNING**

Make certain the unit is adjusted so that the cutting blades are disengaged when the lift handle is in the disengaged position.

**12-7. 32-INCH SIDE DISCHARGE MOWER DECK FOR MODEL 500 SERIES REAR ENGINE RIDING MOWERS.**

12-7.1 This deck is similar to the deck used on the 300 series, except for the mounting brackets and idler system. However, these two decks are not interchangeable. See Figure 12-24.

12-7.2 Remove the deck as follows:



**WARNING**

Disconnect the spark plug wire and ground it against the engine.

1. Lower the deck to its lowest position.
2. Move the blade engagement lever to the engaged position.



3. Remove the top nut from the bolt on the deck brake bracket assembly, and remove spring from the bolt.
4. See paragraph 12-7.3 for deck belt removal and replacement.

5. Remove the hex bolt, lock washer and hex nut from the top hole in the deck engagement bracket. See Figure 12-26.

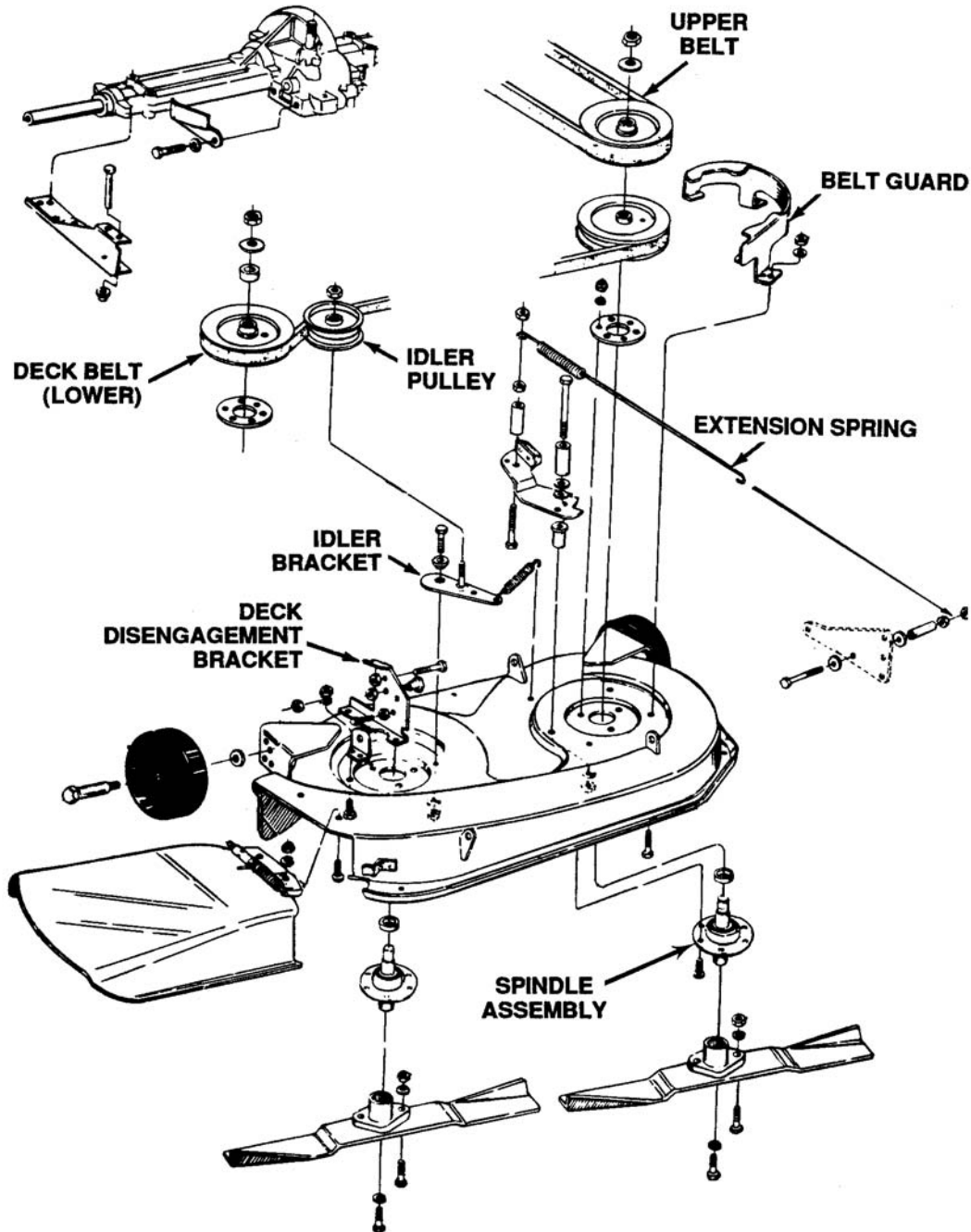


Figure 12-25. 32-Inch Side Discharge Deck

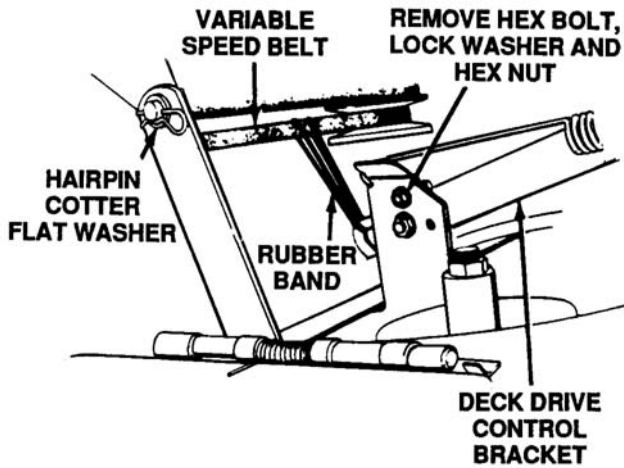


Figure 12-26. Location of Deck Drive Control Bracket

6. Loop a rubber band around and over the variable speed belt. Hook both ends of the rubber band over the slot on the deck drive control bracket.
7. Move the blade engagement lever to the engaged position.
8. Disconnect the deck drive control bracket as follows:
  - a. Push the front of the deck backwards.
  - b. Pivot the deck drive control bracket off the shoulder bolt on the deck engagement bracket.
9. Remove the two hairpin cotters and flat washers which hold the stabilizer shaft assembly to the deck lift brackets on the rider.
10. Remove the two hairpin cotters and flat washers which secure the J-bolts to the front of the deck. See Figure 12-27.

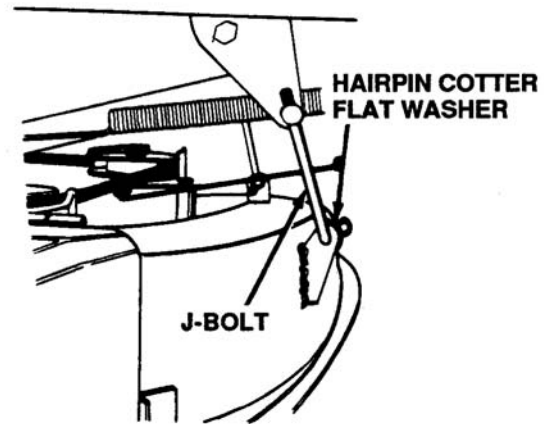


Figure 12-27. Location of J-Bolts

11. Slide the deck from beneath the lawn tractor.

### 12-7.3 Deck Belts Removal and Replacement.

Remove and replace belts as follows:



#### WARNING

Disconnect the spark plug wire and ground it against the engine.

1. Lower the deck to its lowest position.
2. Move the blade engagement lever to the disengaged position.
3. Remove one hex bolt and lock washer at the front of lower outside belt guard. A 1/2 inch wrench is required. See Figure 12-28.

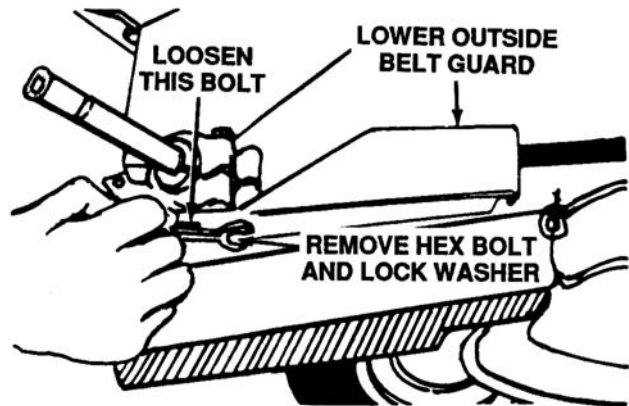
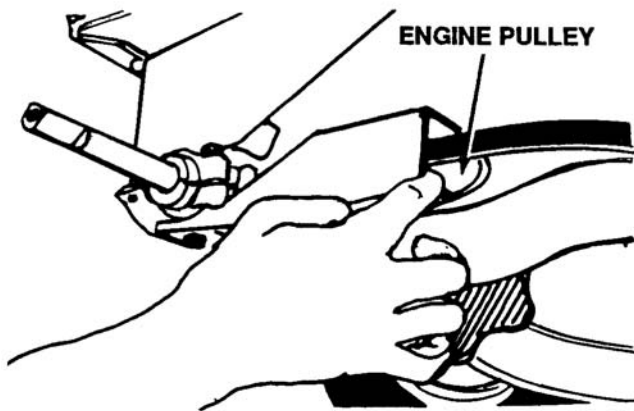


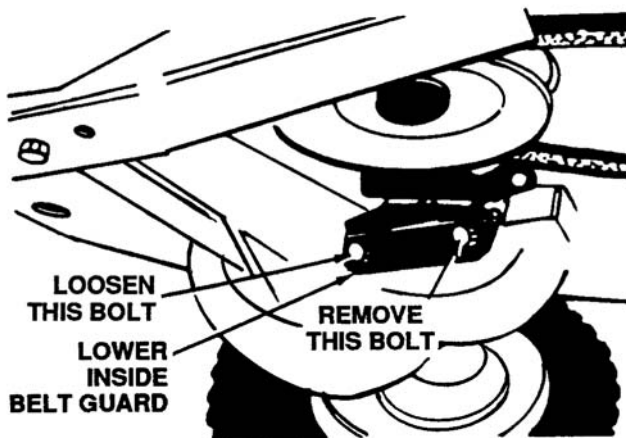
Figure 12-28. Removing Hex Bolt at Lower Outside Belt Guard

4. Loosen (do not remove) the second bolt.
5. Pivot the lower outside belt guard out and away from the engine pulley. See Figure 12-29.



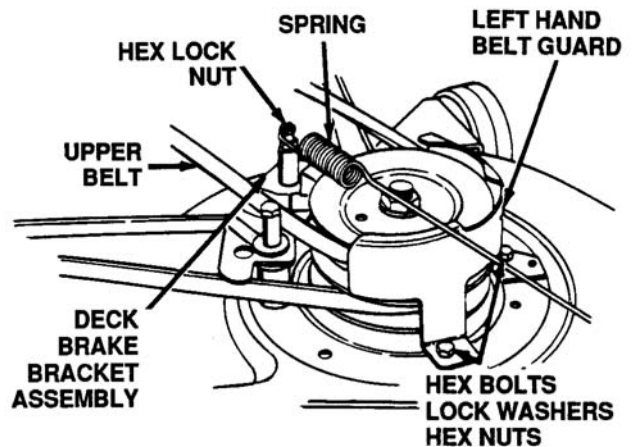
**Figure 12-29. Pivoting Lower Outside Belt Guard Away From Engine Pulley**

6. Remove the front hex bolt from the lower inside belt guard. Loosen the second bolt (do not remove) and pivot the guard downward. Slip the upper deck belt off the engine pulley. See Figure 12-30.



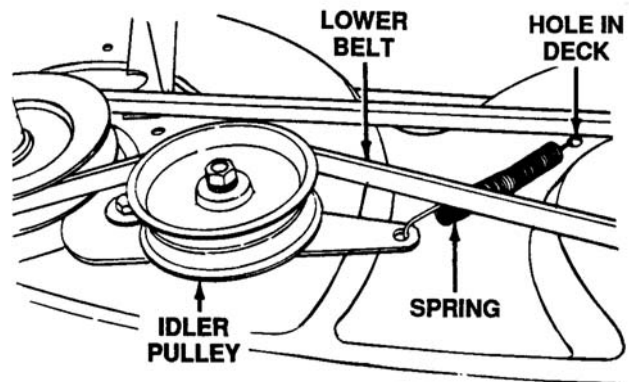
**Figure 12-30. Removing Hex Bolt From Lower Inside Belt Guard**

7. Remove the top hex lock nut from the bolt on the deck brake bracket assembly and remove the spring from the bolt. See Figure 12-31.



**Figure 12-31. Removing Upper Belt From Top Pulley**

8. Remove the left hand belt guard by removing the hex bolts, lock washers and hex nuts. Remove the upper belt from the top pulley.
9. Disconnect the spring on the idler bracket from the hole in the deck. Slip the lower belt over the idler pulley. Roll the belt off the deck pulleys. See Figure 12-32.



**Figure 12-32. Location of Idler Bracket Spring**

10. To replace the belts, first reattach the spring on the idler bracket to the hole in the deck. Work the lower belt over the two deck pulleys and then around the idler pulley.
11. Reassemble by following steps in reverse order.

**12-8 MODEL 836 36-INCH SIDE DISCHARGE MOWING DECK FOR FRONT ENGINE LAWN TRACTORS 600 SERIES.**

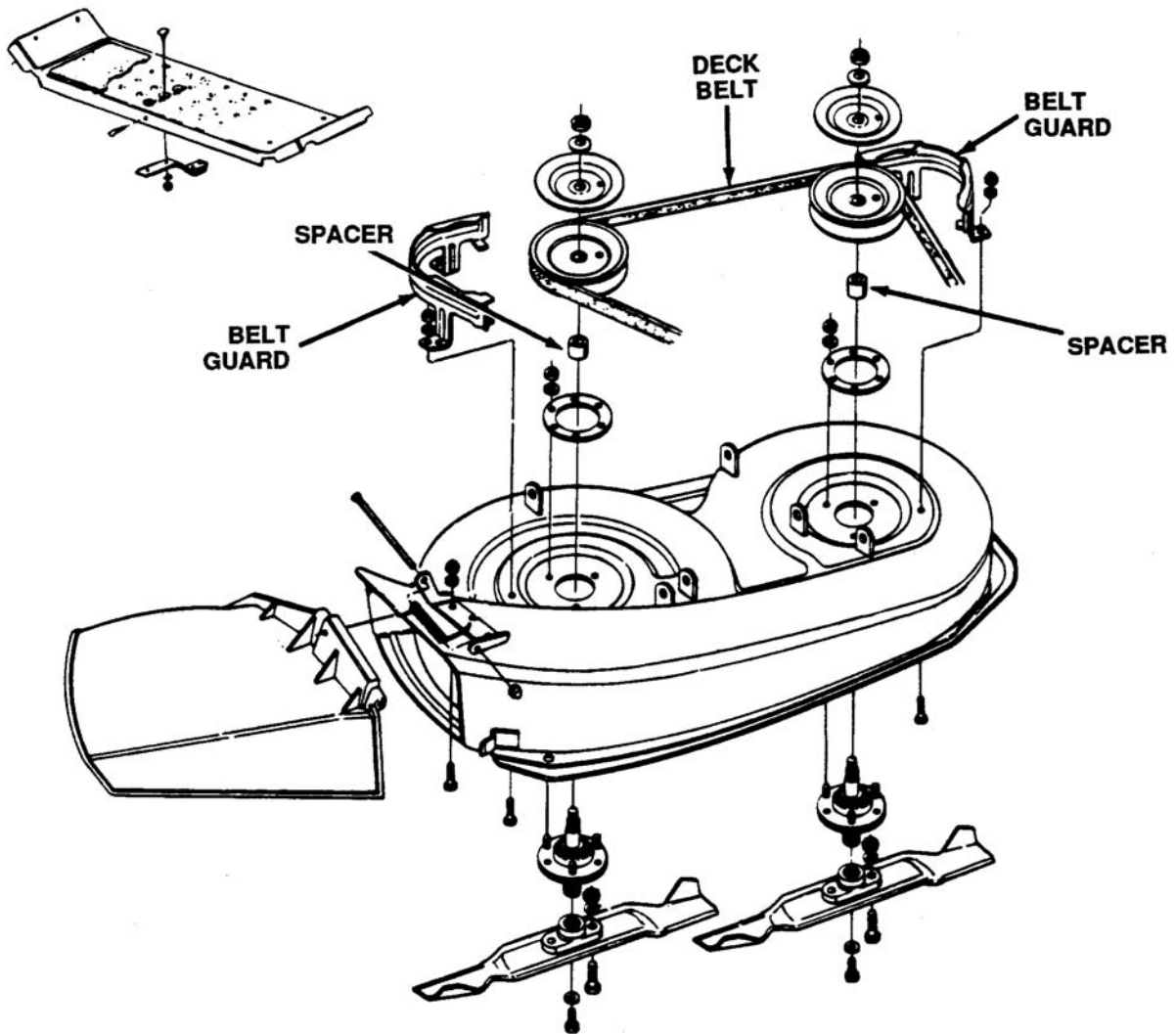


Figure 12-33. Model 836 36-Inch High Vacuum Deck

12-8.1 The high vacuum 36-inch side discharge deck features a special vacuum lift blade which creates increased air flow for superior grass ejection and collection. This deeper deck enables you to performance match your tractor with the optional Model 063 twin bag grass collector system which fits this deck. The deck is interchangeable with 1990 and prior production models. The deck is attached to the lawn tractor in the same manner as the 38-inch side discharge deck and the procedure for removing the deck belt is also the same. See Figure 12-33.

#### 12-8.2 Deck Belt Removal and Replacement.

1. Place the lift lever in the disengaged position.
2. Remove the hex bolts (belt keepers) from the engine pulley belt guard. See Figure 12-34.

#### ➡ NOTE

Your unit will have either two or three hex bolts. When reassembling, make certain hex bolts are assembled in the same locations from which they were removed.

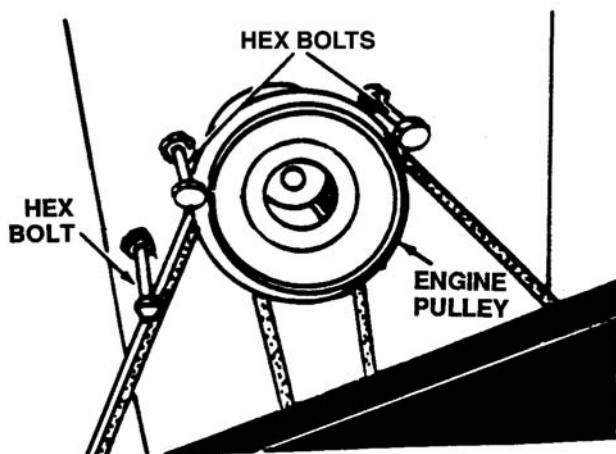


Figure 12-34. Location of Hex Bolts (Belt Keepers)

**NOTE**

Figure is shown with the unit tipped up for clarity. It is not necessary to tip the unit to remove the belts.

3. Unhook the deck belt from the engine pulley.
4. Place the lift lever in the engaged (all the way forward) position.
5. Disconnect the six deck links by removing the hairpin cotters and flat washers.
6. Place the lift lever in the disengaged position.
7. Slide the deck from beneath the lawn tractor.
8. Remove the belt guards at each deck pulley by removing the hex bolts, lock washers and hex nuts. See Figure 12-35.

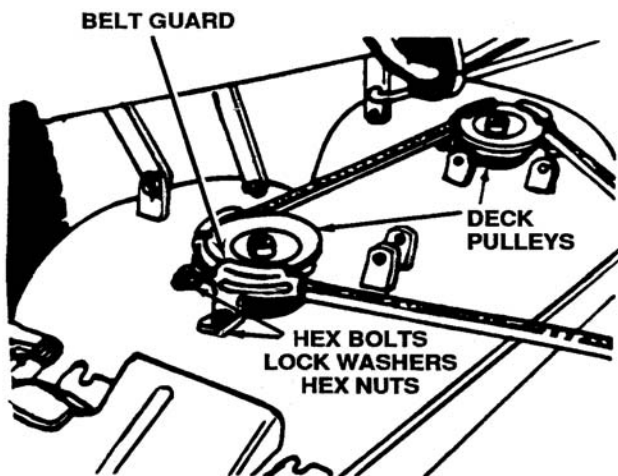


Figure 12-35. Removal of Belt Guards

9. Remove and replace the belt, following the instructions in reverse order.

**12-9. MODEL 805 38-INCH SIDE DISCHARGE MOWING DECK FOR FRONT ENGINE LAWN TRACTORS MODEL 500 AND 600 SERIES.**

**NOTE**

The Model 805 was a very popular deck and owners with the older 801 decks (prior to 1989) could change over to the 805 deck using kit, part number 753-0447. If the unit had a Peerless transaxle you have to change the engine pulley, part number 756-0513.

**NOTE**

There were two deck deflectors manufactured, one plastic and one metal, and they are not interchangeable.

- 12-9.1 The high vacuum 38-inch side discharge deck features a special vacuum lift blade which creates increased air flow for superior grass ejection and collection. This deck will accept the 063 twin bag grasscatcher and is interchangeable with units produced prior to 1990 with 805 decks. See Figure 12-36.

- 12-9.2 New sand blades are now available for the 38-inch deep deck, for use in areas where sandy conditions may prematurely wear the original blades. These new blades are made from harder material, and test results show that the sand blades last longer than the original blades under these conditions. Order part number 724-0493A (2 per unit).

- 12-9.3 Two decks were made available, one with and one without wheels. The wheel assemblies are welded and the customer would have to order the entire deck assembly if he/she wants deck wheels. 38-inch decks with wheels are for hilly terrain and help avoid scalping. Units without wheels are good for even terrain. Order as follows:

1. 38-inch deck assembly complete without deck wheels, part number 813-06102.
2. 38-inch deck assembly complete with deck wheels, part number 801-7503.

- 12-9.4 The F deck came with optional wheels. Some decks had wheels with welded wheel brackets,

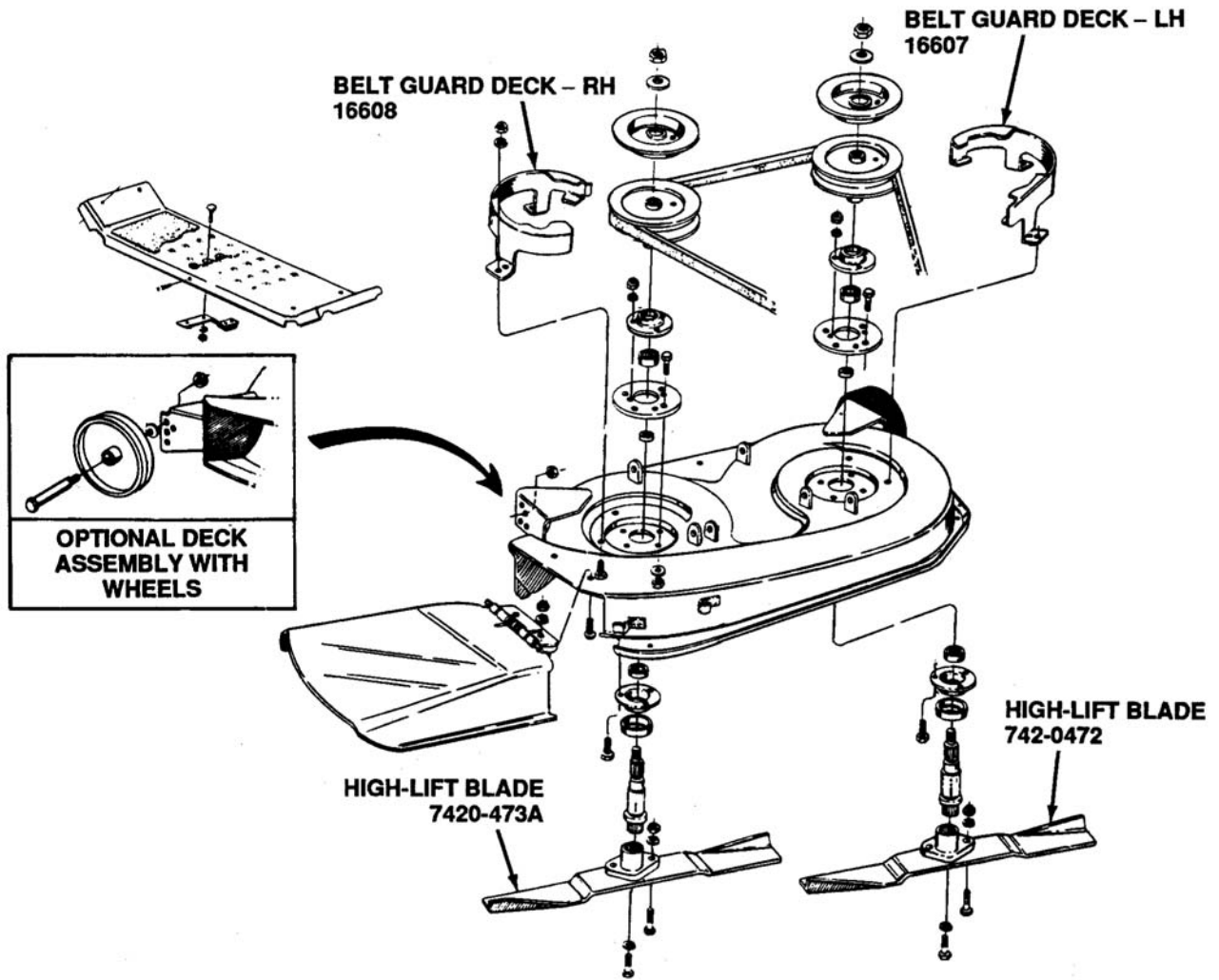


Figure 12-36. 38-Inch High Vacuum Deck

# IMPROVEMENTS

## New Blade Spindle for 1997 Lawn Tractors

The new cast aluminum spindle housing is improved due to the following:

- Made of cast aluminum vs. two stamped steel parts which had to be welded.
- “Star” Blade Driver will help promote OEM blade sales as it will be a patented design. No “will-fit” blades will work.
- Parts have been reduced on total blade assembly from 44 on old spindle to 15 parts on new spindle.
- Better bearing placement on new spindle for longer life. Bearings have been moved further apart to significantly extend bearing life.



OLD

Figure 12-37. Blade Spindle



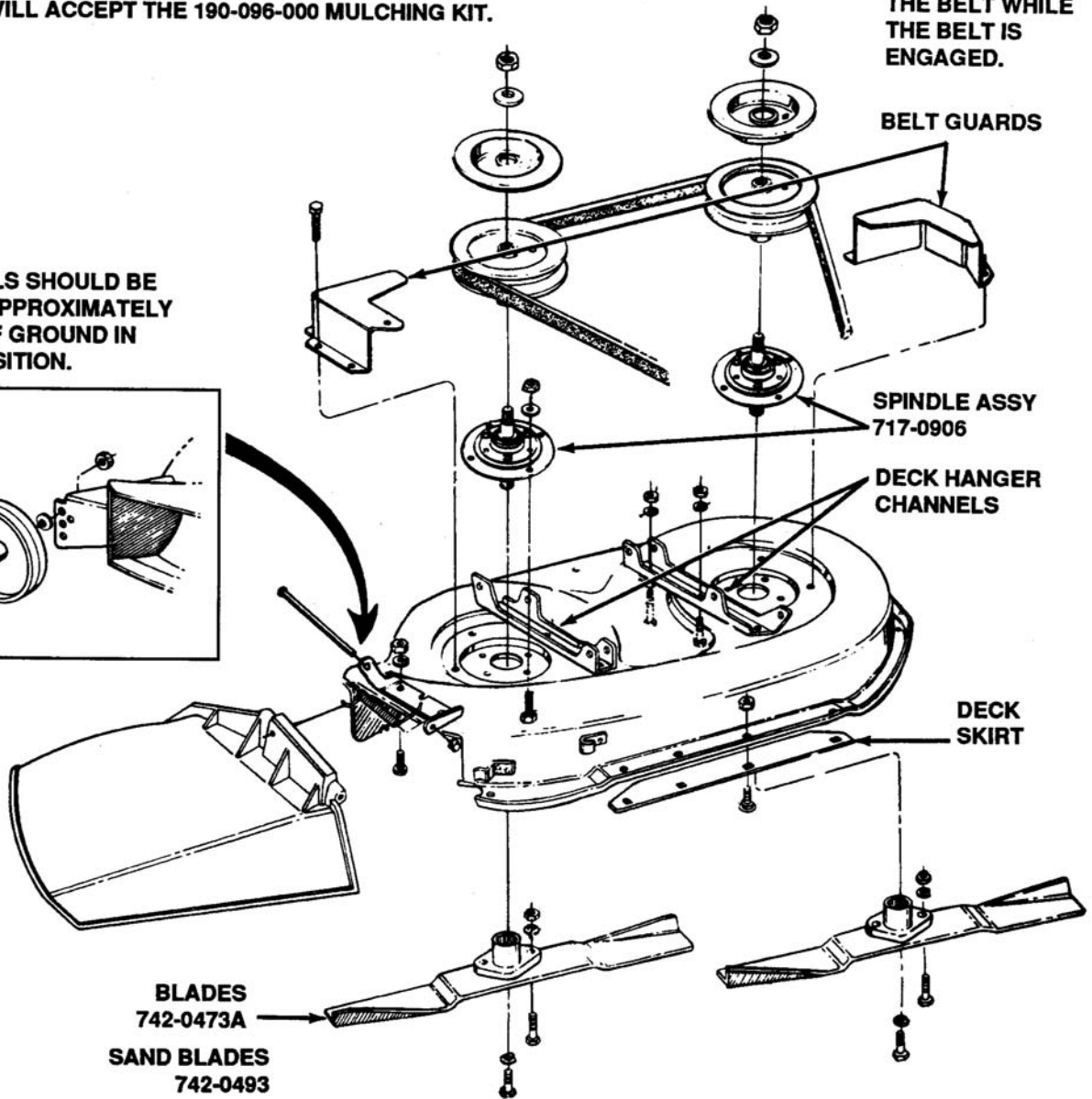
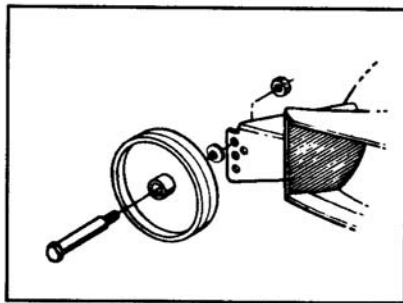
NEW

Figure 12-38. Cast Aluminum Blade Spindle

**FOR 500 AND 600 SERIES LAWN TRACTORS  
THIS DECK WILL ACCEPT THE 190-096-000 MULCHING KIT.**

**BELT GUARDS  
MUST ALWAYS BE  
1/8" AWAY FROM  
THE BELT WHILE  
THE BELT IS  
ENGAGED.**

**DECK WHEELS SHOULD BE  
ADJUSTED APPROXIMATELY  
1/4 TO 1" OFF GROUND IN  
CUTTING POSITION.**



**Figure 12-39. 38-Inch Model "F" Deck With Deck Skirt**

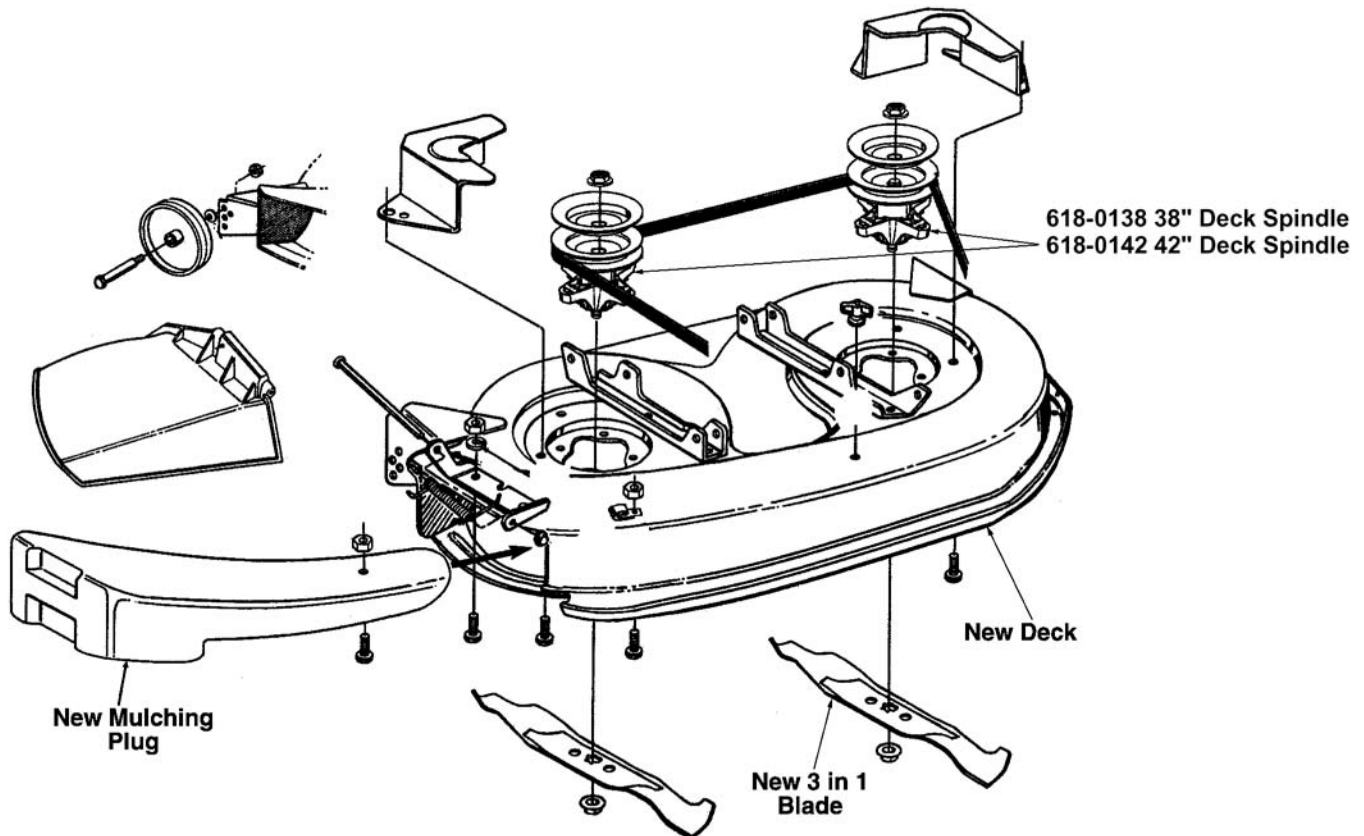
**600 series 38" decks 1988 and prior units with (non adjustable decks)**

We have found in some instances when using the deck belt part numbers (754-0433) and (754-0329A) the deck will not disengage. In some cases the linkage may be bent and need to be replaced if all the linkage is to specs you can remove the rear belt guard facing the side chute deflector, the other two belt guards must be positioned 1/8" away from the belt when the belt is engaged. This will allow the belt to push forward around the engine pulley and disengage the deck.



## New 1996 38" and 42" Decks (Late Production)

The 38" and 42" cutting decks have a noticeable change in them. The leading front edge is now flat and in line with the ground, no bolt on baffle or open ends normally used for air intake. The air now enters the deck from each spindle assembly from the top, all around the spindle area. This also eliminates the cut grass from getting pushed out the front and flying up on top of the deck. The opening around the spindle assembly improves the air flow and mulching capabilities. The mulch plugs for the 38" and 42" are the same, thereby, lessening inventory by having to stock two models of mulching plugs.



The plug only for the 38"/42" is part #731-1643A.

The three in one blade is #742-0616 for the 42" decks.  
The three in one blade is #742-0610 for the 38" decks.

Figure 12-40. 1996 Late Production 38" and 42" Decks

The "New" mulching kit for the 38" and 42" is #190-112-000. The new kits install much easier than the previous models. To install you will simply push in and line up fixed bolt at the end of the mulching plug with the hole in the deck housing and install a wing-nut and tighten, no tools required.

others had no wheels or brackets, depending on how the unit was specified. Some also come with deck skirts. There are four different styles:

1. 38-inch deep deck with deck wheels, complete assembly, part number 801-7503. This unit comes with the deck skirt. See Figure 12-39
2. 38-inch deep deck shell, with wheel brackets, part number 17503A. It will not come with the deck skirt, part number 17863.
3. 38-inch deep deck without deck wheels, complete assembly, part number 813-06102. Comes with deck skirt.
4. 38-inch deep deck shell, without wheel brackets, part number 17717A will not come with a deck skirt, part number 17863.

12-9.5 In a few cases involving 1989 style 8, 600 series tractors, there was a problem with the unit burning grass if left running in one spot. A heat shield kit, part number 753-0501, was made available for that problem.

#### 12-9.6 Deck Belt Removal and Replacement.

1. Place the lift lever in the disengaged position.
2. Remove the hex bolts (belt keepers) from the engine pulley belt guard. See Figure 12-41.

#### ➡ NOTE

Your unit will have either two or three hex bolts. When reassembling, make certain hex bolts are assembled in the same location from which they were removed.

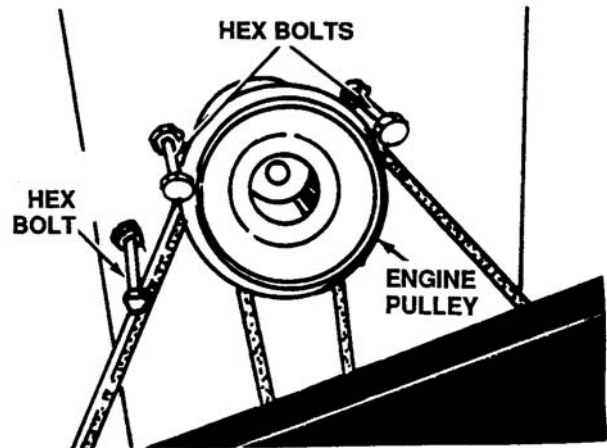


Figure 12-41. Location of Hex Bolts (Belt Keepers)

3. Unhook the deck belt from the engine pulley.
4. Place the lift lever in the engaged (all the way forward) position.
5. In lawn tractors equipped with a stabilizer plate attached to the deck, disconnect the spring which is attached to a bracket on the transaxle inside the left rear wheel. Use a spring puller or other suitable tool.
6. Disconnect the six deck links by removing the hairpin clips and flat washers.
7. In lawn tractors equipped with a stabilizer plate attached to the deck, disconnect the stabilizer plate from the stabilizer shaft assembly by removing the hairpin clips and flat washers and sliding out the rod.
8. Place the lift lever in the disengaged position.
9. Slide the deck from beneath the lawn tractor.
10. Remove the belt guards at each deck pulley by removing the hex bolts, lock washers and hex nuts or self-tapping screws (as equipped). See Figure 12-42.

#### ➡ NOTE

When servicing these decks, check the belt guards for proper alignment. They should be 1/8 inch away from the belt.

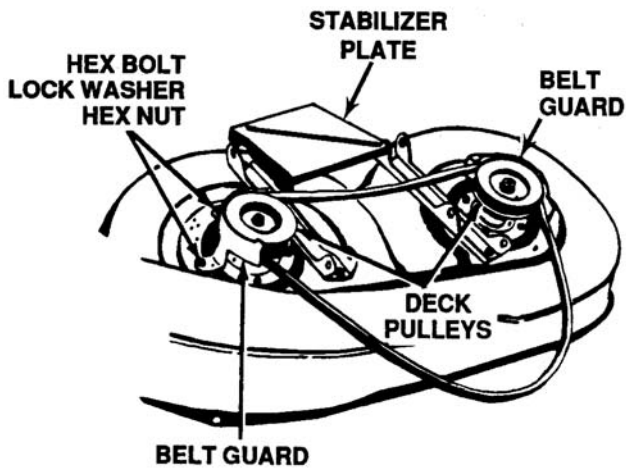


Figure 12-42. Removing Belt Guards

11. Remove and replace the belt, reassemble following the instructions in reverse order.

12-9.7 1989 and prior units use belt, part number 754-0433, for the 38-inch deck. From 1990 through 1992 model F 38-inch deck, the deck belt, part number 754-0329A, will work on these units. This belt will be cross referenced to a new part number 754-0433. This belt was changed due to problems with older units being unable to disengage the blades after installing belt, part number 754-0329A. The belt, part number 754-0433, will work on both prior and present 38-inch deep deck units.

12-9.8 Deck Leveling Adjustment (See Figure 12-43).

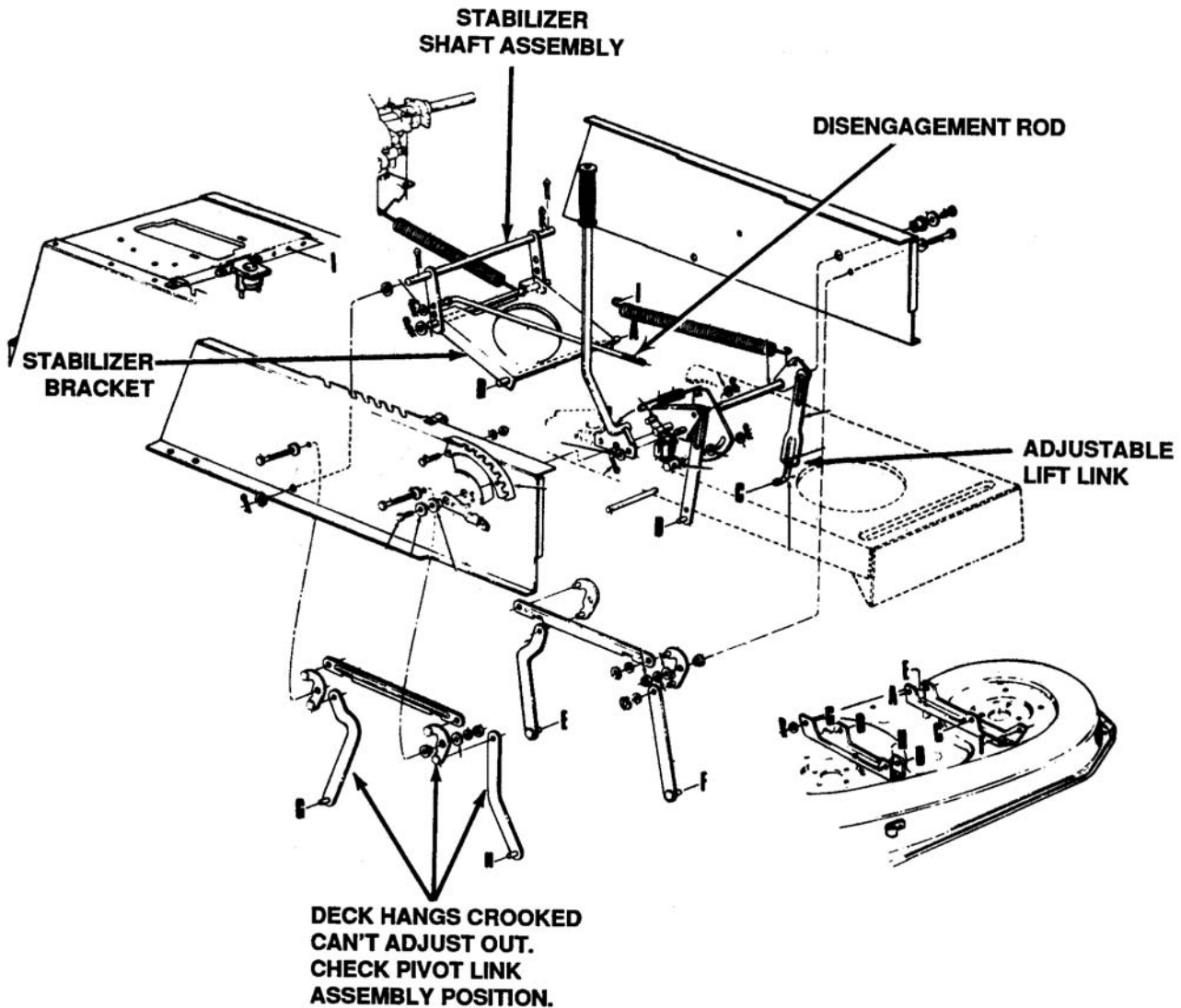


Figure 12-43. Model Series 600 Deck Attachment

1. Move and lift the disengagement lever forward (lower the cutting deck). Make certain the deck wheels (if so equipped) are not resting on the ground.
2. With unit on hard, level surface, measure the distance from the bottom edge of the center of the left side of deck to the ground. Measure the same distance on the center of the right side of the deck (just behind the chute area on side discharge units). Or, place the blades in a straight line and measure distance from the outside edge of the blade tips to the ground.
3. Disconnect the bottom of the adjustable lift link from the deck, on the left side of the unit, by removing the hairpin clip and flat washer. See Figure 12-44.
4. Pull the adjustable lift link out of the deck hanger channel.

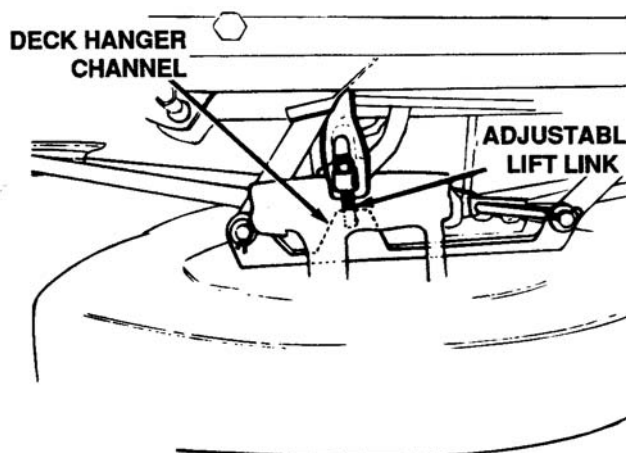


Figure 12-44. Deck Leveling Adjustable Lift Link

5. Thread the adjustable link in or out as necessary to level the deck. Reassemble the link. Check the adjustment and readjust as necessary.

### 12-9.9 Cutting Deck Engagement Adjustment (See Figure 12-43).

1. Place the lift lever in the highest cutting height position (first slot in the index bracket).
2. Disconnect the disengagement rod from the stabilizer shaft assembly by removing the hairpin clip and flat washer. See Figure 12-45.

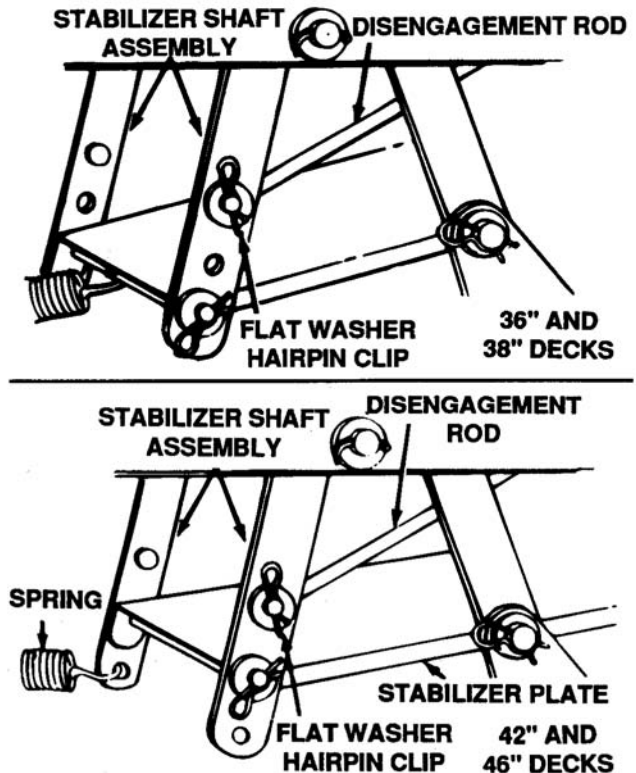


Figure 12-45. Deck Disengagement Adjustment Rod

3. Thread disengagement rod in or out of ferrule until ferrule is against the back of the slot in lift shaft assembly and disengagement rod lines up with holes in stabilizer shaft assembly. Shorten disengagement rod for less belt tension, lengthen for more belt tension.

### ➡ NOTE

Lower the lift lever (and the deck) so you can turn the disengagement rod easily. Then reposition the lift lever in the first cutting height position to check the adjustment.

4. When correct adjustment is reached, secure the disengagement rod with flat washer and hairpin clip.
5. Check adjustment by pulling all the way back on the lift lever. The deck should move upward and forward and the deck belt should be slack. Move the lift lever to any of the engaged positions. The lift lever should fall easily into any of the slots in the index bracket.



**WARNING**

After starting the engine, make certain the blades are not in the disengaged position, and that the blades are engaged when lift lever is moved forward to any of the engaged positions. If necessary readjust the disengagement rod.

**12-10. 42-INCH SIDE DISCHARGE DECK FOR 600 AND 700 SERIES FRONT ENGINE LAWN TRACTOR.**

12-10.1 This deck offers the same features as the 38-inch deep deck with added bolt on baffles. This

**1986 THRU 1996 805 DECKS  
FOR 600 AND 700 SERIES LAWN TRACTORS  
THIS DECK WILL ACCEPT THE 097 MULCHING KIT.**

will improve the deck vacuum and enhance bagging performance. The front baffles will retrofit 1990 42-inch decks. See Figure 12-46. It also will include all new lift assembly features and will accept the 063 twin bag grasscatcher. This deck will not interchange with 1989 and prior units because of the new design lift system and deck. The transaxle was moved back in the frame approximately 1/2 inch.

**NOTE**

When ordering 42-inch deep deck assembly, baffles, part numbers 17861A and 17961, are not included.

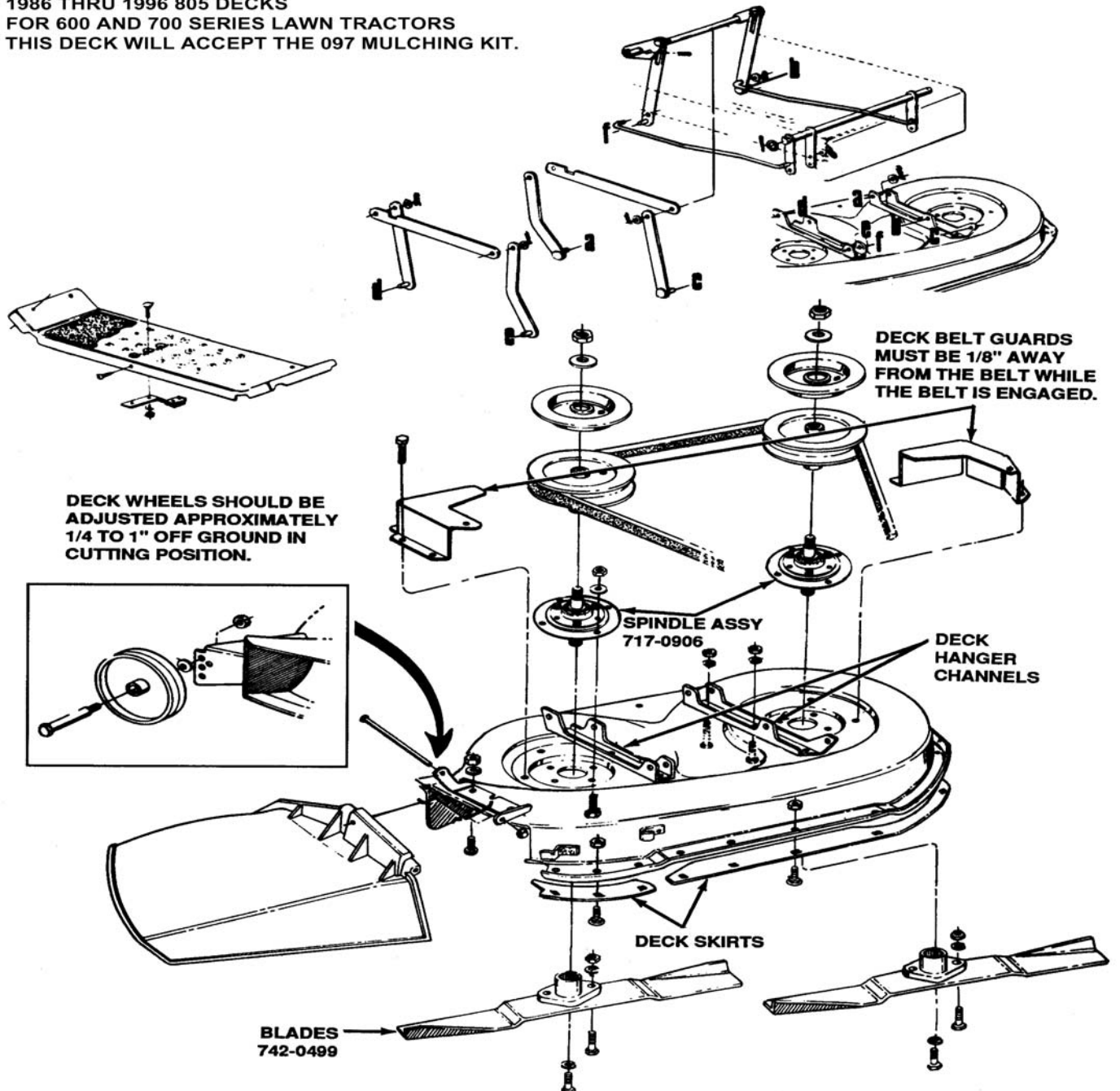
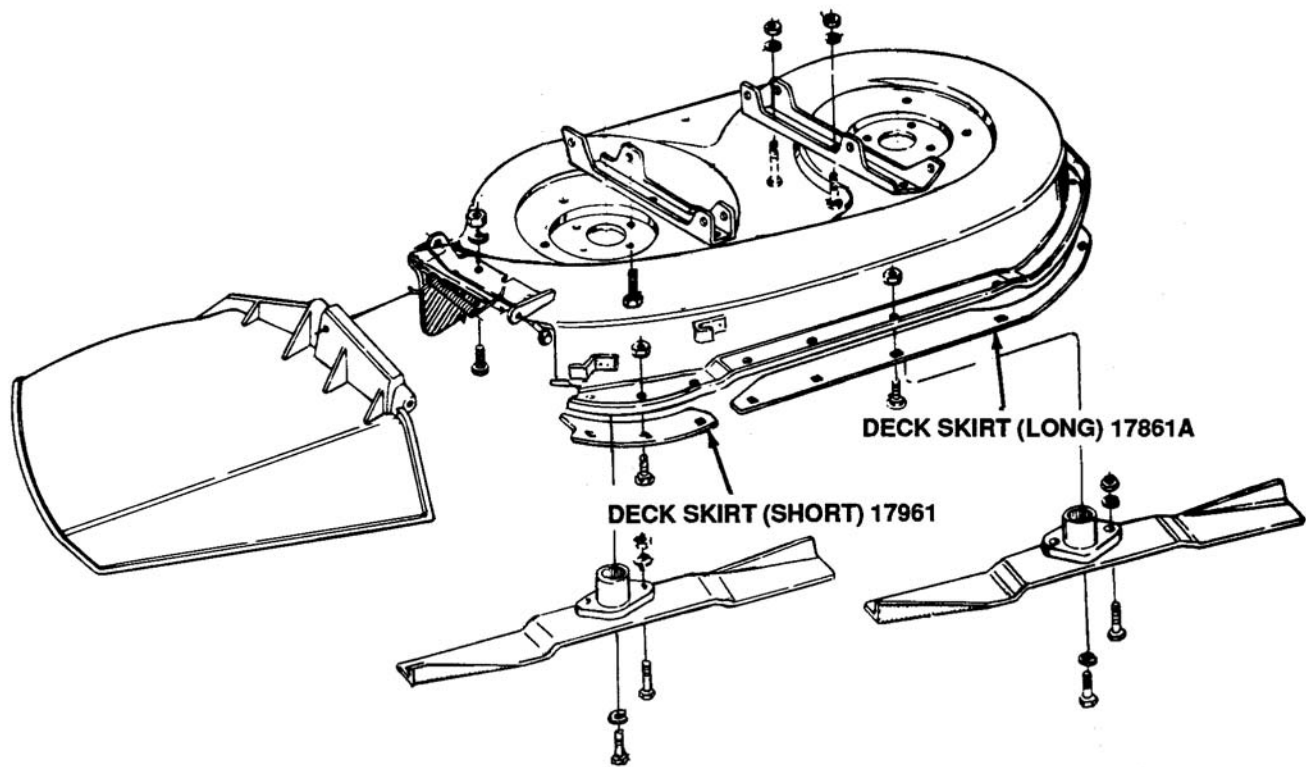


Figure 12-46. Model G 42-Inch Side Discharge Deck



**Figure 12-47. Location of Deck Skirts**

12-10.2 In 1990 a deck skirt kit, part number 753-0513, was added to the product line to improve the vacuum of the deck. The change was incorporated in 1991. When ordering deck skirts there are two sizes, a short, part number 12961, and a long, part number 17861A. See Figure 12-47.

**12-10.3 Deck Leveling Adjustment.** Refer to paragraph 12-9 covering 38-inch side discharge deck.

**12-10.4 Deck Belt Removal and Replacement.** Refer to paragraph 12-9 covering 38-inch side discharge deck.

**12-10.5 Deck Engagement Adjustment.** Refer to paragraph 12-9 covering 38-inch side discharge deck.

**12-11. MODEL SERIES 600 “H” 46-INCH SIDE DISCHARGE DECK FOR 600 AND 700 SERIES FRONT ENGINE LAWN TRACTOR (See Figure 12-48).**

**12-11.1 Deck Leveling Adjustment.** Refer to paragraph 12-9 covering 38-inch side discharge deck.

**NOTE**

The 42-inch deck stabilizer plate mounts in the second hold of the stabilizer shaft assembly. The 38-inch mounts in the bottom hole.

**12-11.2 Deck Belt Removal and Replacement.** Refer to paragraph 12-9 covering 38-inch side discharge deck.

**12-11.3 Deck Engagement Adjustment.** Refer to paragraph 12-9 covering 38-inch side discharge deck.

**12-12. MODEL 803 44-INCH SIDE DISCHARGE MOWING DECK FOR MODEL 700 SERIES LAWN TRACTORS.**

12-12.1 This deck was designed specifically for the 700 series tractor. The deck is similar to the 935, 44-inch side discharge, except for the mounting brackets. These two decks are not interchangeable. See Figure 12-50.

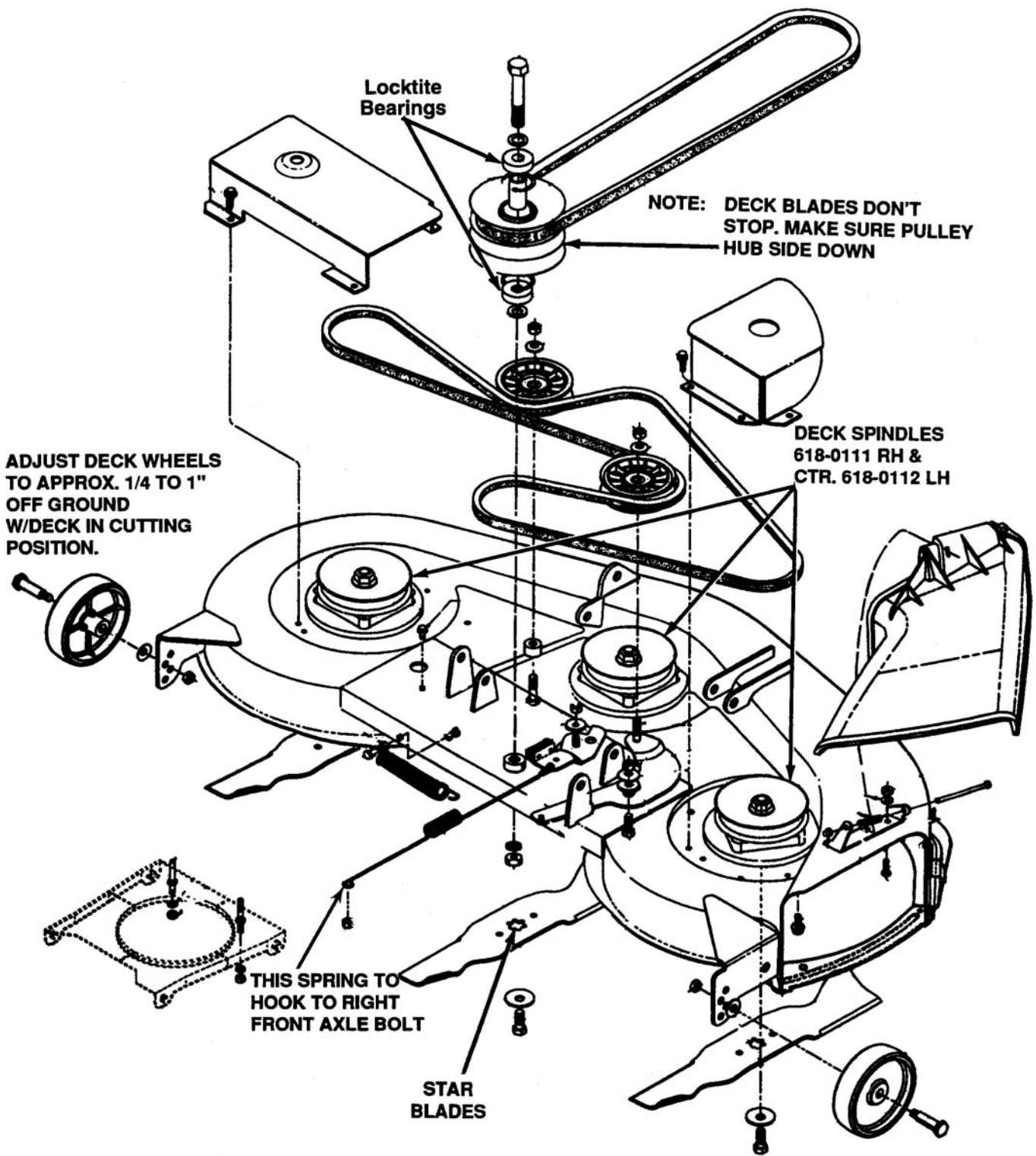


Figure 12-48. Model Series 600 "H" 46-Inch Deck

## New 1996 Deck "H" (46")

The 46" deck has not been changed except that now it has a mulching plug and different blades that are all purpose and need not be changed when mulching. The 46" deck still has the bolt on baffle in front which has performed exceptionally well. The new molded mulching plug for the 46" deck is similar to the 38" plug but in comparison is much longer.

The plug number is #731-1636 and the "NEW" accessory kit number is 190-118-000. The spindle assembly for the 46" deck is #618-0240 and #618-0241. These spindle assemblies have a new patented star design with the external stud, similar to those on the 38"/42" decks. The new spindles will not service an older star spindle due to the change in the star design.

The "New" three in one blades are (2) #742-0611 and (1) #742-0612. They will mulch, side discharge, and bag a higher capacity of grass. These blades are not the high-lift design. Beginning in 1997, some 46" decks will be shipped with mulching kits. These units that include the kit will be shipped with the three in one blades mounted on the unit and the mulching plug installed. The bagging blades will be shipped in a separate box similar to the old mulching kits. If the customer later buys a bagging kit, he will then mount the (2) 16.28" #742-0644 and the (1) #742-0645 blades. These blades will be mounted if a mulcher kit is not specified for the unit.

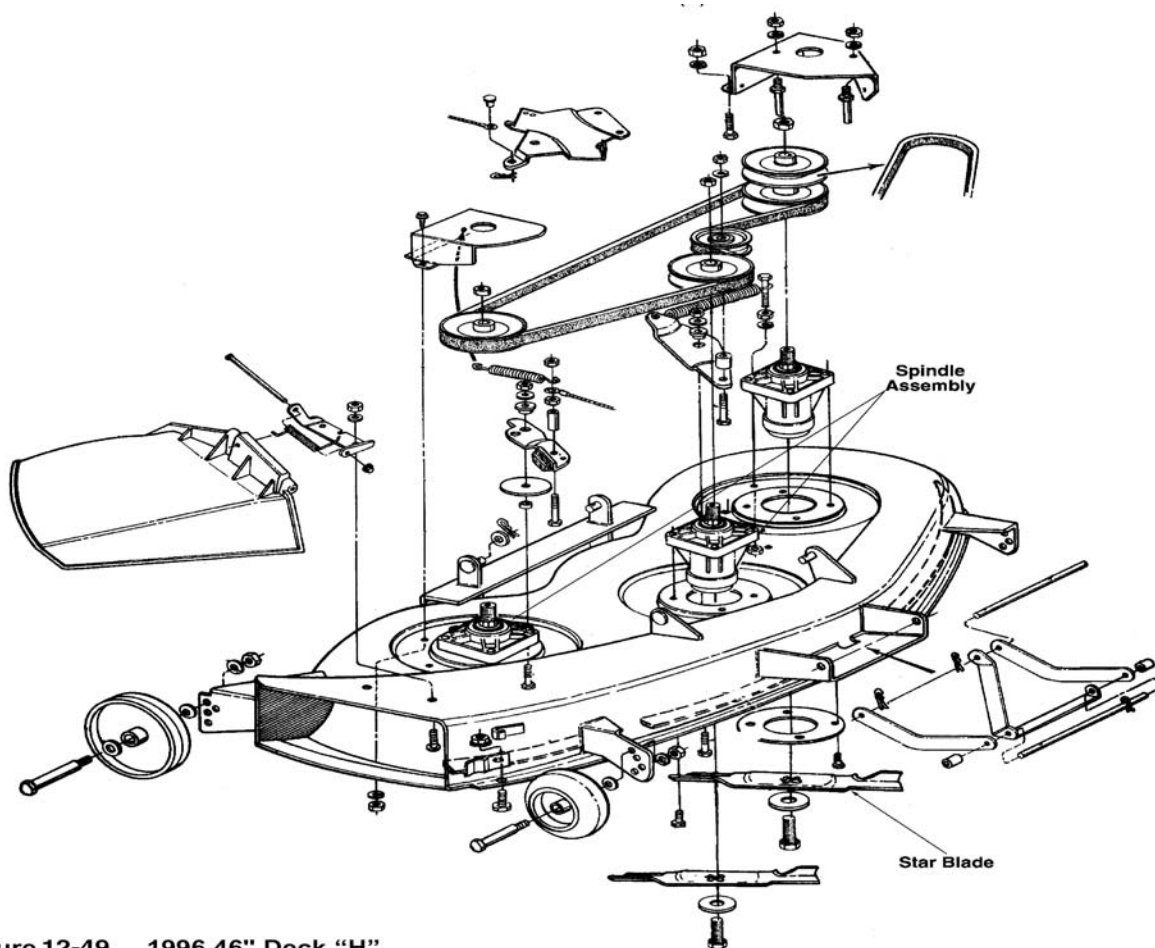


Figure 12-49. 1996 46" Deck "H"

The mulcher kit number 190-117-000 is for 46" decks for 1990-1996.

This kit contains:

1. Mulching Plug
2. (3) Mulching Blades
3. (3) New Spindles, with the "NEW" Star Design
4. Instructions

The mulcher kit number 190-118-000 is for 46" decks 600 and 800 series for 1997.

This kit contains:

1. Mulching Plug
2. (3) Mulching Blades
3. Instructions

Mulcher Kit 190-113-000 is for 46" decks 800 series for 1996 and prior.



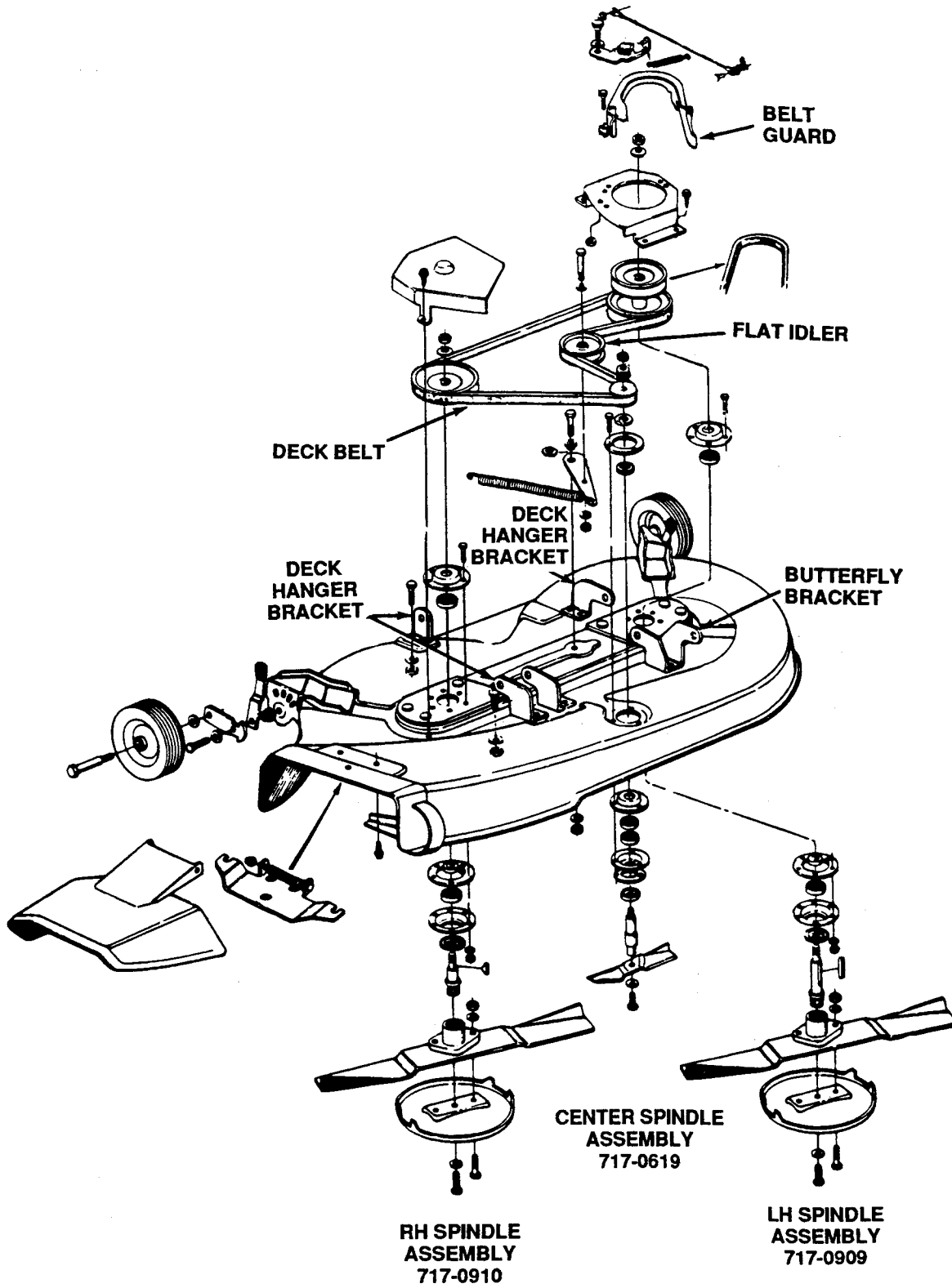


Figure 12-50. Model 803 44-Inch Side Discharge Deck

### 40" REAR DISCHARGE DECK

If you encounter a deck drive problem, check the deck idler arm for alignment.

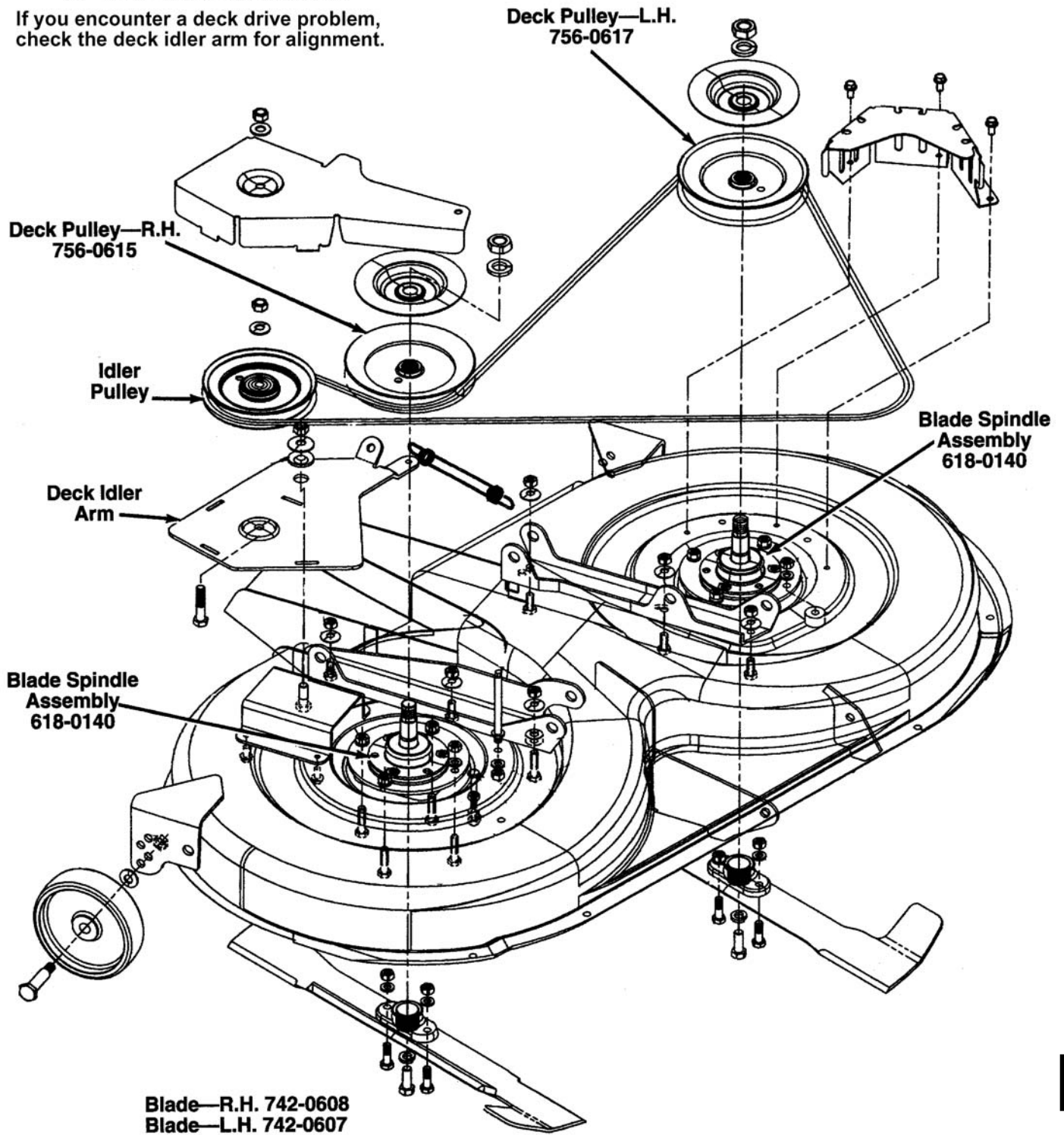


Figure 12-51. Models 760 thru 769 Series Rider Deck

## 12-12A.Models 760 thru 769 Series Rider



### 12-12A.1 LEVELING THE DECK

With unit on hard, level surface, measure the distance from the bottom edge of the center of the left side of deck to the ground. Measure the same distance on the center of the right side of the deck. Or, place the blades in a straight line, and measure the distance from the outside edge of the blade tips to the ground.

If adjustment is needed, proceed as follows.

1. Remove the hairpin clip and flat washer from the bottom of the adjustable lift link on the left side of the deck. (Hairpin clip and flat washer are on the inside of the lift link.)
2. Pull the adjustable lift link out of the deck hanger channel. See Figure 12-52. Turn the adjustable lift link up or down as necessary to level the deck. Usually only one or two turns are needed.
3. Insert the end of the adjustable lift link into the hole in the deck hanger channel. Recheck the adjustment. Readjust if necessary.
4. When deck is level, secure end of adjustable lift link with flat washer and hairpin clip.

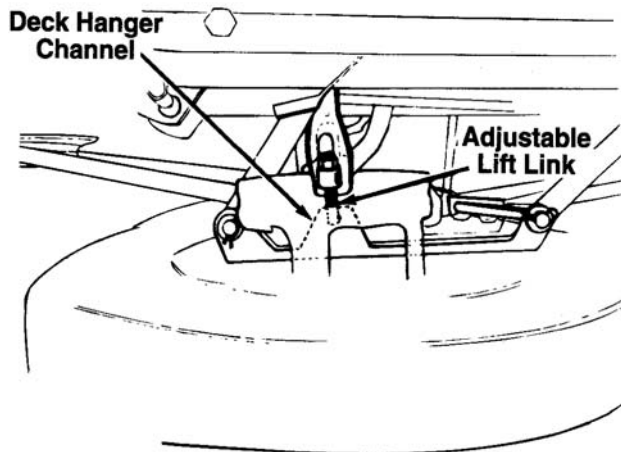


Figure 12-52. Leveling the Deck

### 12-12A.2 CUTTING CONTROLS

#### A. LIFT LEVER

The lift lever is used to raise and lower the cutting deck and to engage and disengage the blades. Pulling it all the way back and locking it disengages the blades.

The lift lever **must** be in the **BLADES OFF** position when starting the engine, when shifting into reverse and if the operator leaves the seat.

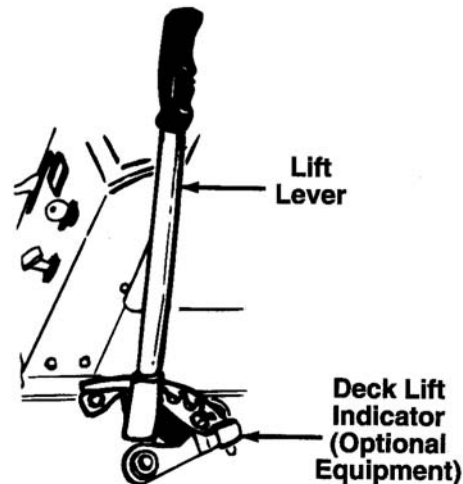


Figure 12-53. Cutting Controls

#### B. DECK LIFT INDICATOR (Optional Equipment)

If so equipped, the deck lift indicator marks the position being used for the lift lever. Select the lift lever position desired, press the indicator lever outward, move it to the position immediately below the lift lever and release the indicator lever.

#### C. SETTING THE CUTTING HEIGHT

1. Select the position for the lift lever which gives the desired cutting height. Move the deck lift indicator (if so equipped) so that the lift lever can be returned to the same position after it is raised.
2. Move the deck wheels (if so equipped) to the hole

### 12-12A.3 OPERATING THE CUTTING BLADES

**IMPORTANT:** A safety switch has been installed on the grass collector support. The engine will shut off if the grass collector is not in place with the lift lever engaged.

The cutting blades may be engaged while the lawn tractor is moving or standing still. DO NOT engage the cutting blades abruptly as the sudden belt tension on the pulley may cause the engine to stall.



### WARNING

The mower cannot be operated without the entire grass collector in place.



### NOTE

Under normal usage bag material is subject to wear, and should be checked periodically. Be sure any replacement bag complies with the mower manufacturer's recommendations. For replacement bags, use only factory authorized replacement bag.

## Models 760 thru 769 Series Rider

### 12-12A.4 CUTTING DECK ENGAGEMENT ADJUSTMENT

The cutting deck engagement may be adjusted to make certain deck is disengaged when lift lever is in the BLADES OFF position, or to obtain more drive in the cutting positions. Correct adjustment as follows.

With the engine off, place the lift lever in the highest cutting position (first position). Remove the cotter pin and flat washer which secure the disengagement rod to the engagement link. Shorten the rod by threading it in the ferrule until the rod lines up with the hole in the engagement link. For more belt tension the disengagement rod must be lengthened. To decrease belt tension the disengagement rod must be shortened.

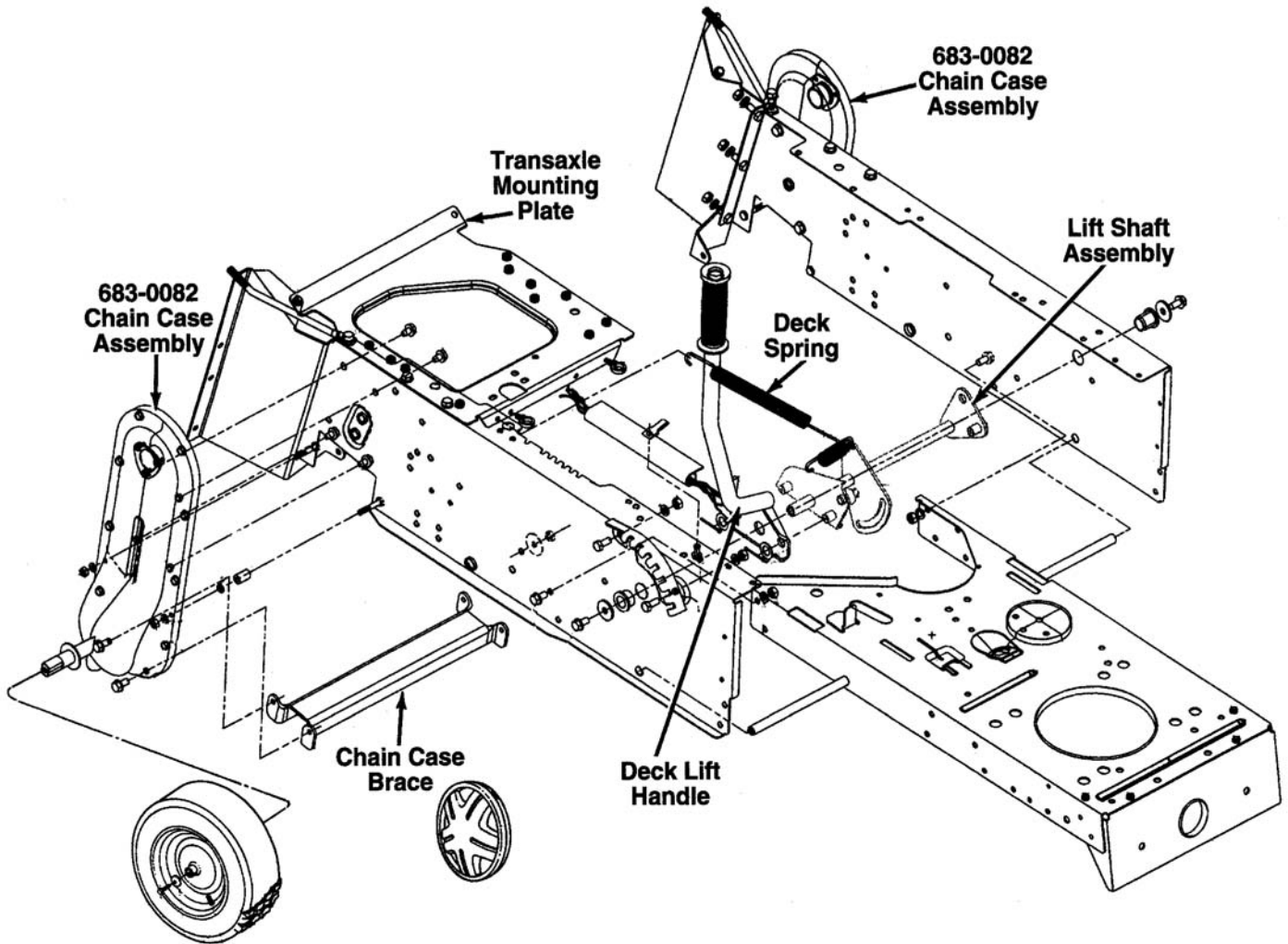


Figure12-54. Models 760 thru 769 Deck Attachment

Check the adjustment by placing the lift lever in the BLADES OFF position. The deck should move up and forward, allowing the belt to become loose. Start and test for disengagement. Repeat procedure as necessary.

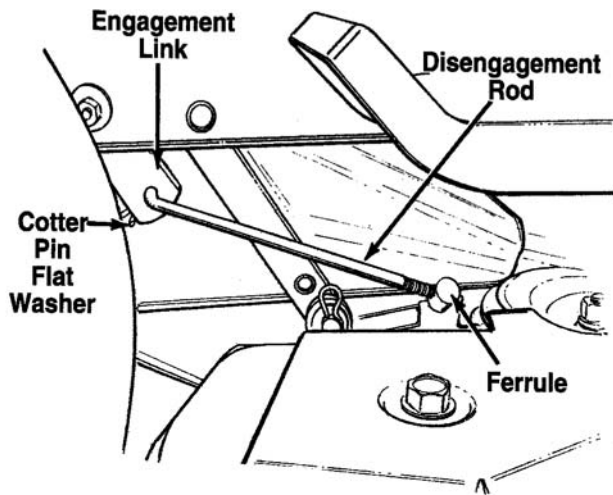


Figure 12-55. Deck Engagement Adjustment

### 12-12A.5 Sharpening

When sharpening the blades, follow the original angle of grind as a guide. It is extremely important that each cutting edge receives an equal amount of grinding to prevent an unbalanced blade. An unbalanced blade will cause excessive vibration when rotating at high speeds, may cause damage to the mower and could break, causing personal injury.

The blade can be tested for balance by balancing it on a round shaft screwdriver. Remove metal from the heavy side until it balances evenly.

#### ➡ NOTE

It is recommended that the blade always be removed from the adapter for the best test of balance.

### Blade Mounting Torque

Center Bolt: 450 in. lbs. min., 600 in. lbs. max.  
Blade Adapter Bolts (if applicable): 200 in. lbs. min., 350 in. lbs. max.

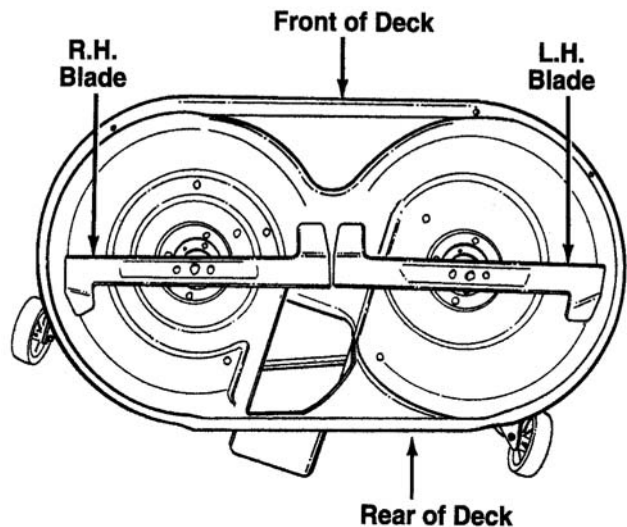


Figure 12-56. Blade View

### 12-12A.6 DRIVE BELT REMOVAL AND REPLACEMENT



#### WARNING

Disconnect the spark plug wire and ground it against the engine. Block the wheels of the unit.

#### Models 760 thru 769 Series Rider

#### DECK BELT

1. Place the lift lever in the BLADES OFF position.
2. Remove the belt keeper pins from the engine pulley belt guard.

#### ➡ NOTE

*When reassembling, make certain belt keeper pins are assembled in the same locations from which they were removed.*

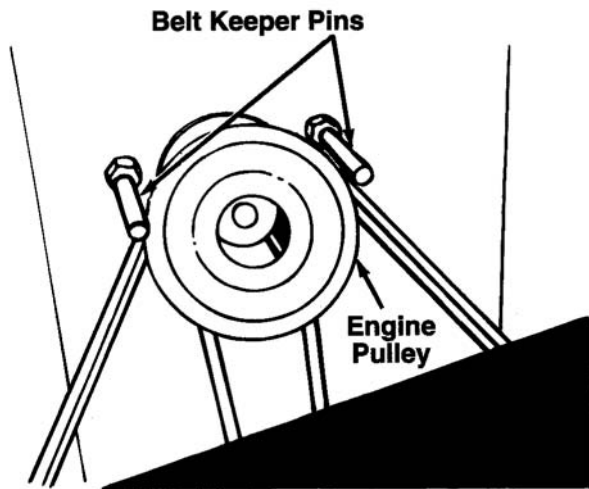


Figure 12-57. Deck Belt Assembly

3. Unhook the deck belt from the engine pulley.
4. Place the lift lever in the BLADES ON (all the way forward) position.
5. Remove the cotter pin and flat washer which secure the disengagement rod to the engagement link.
6. Disconnect the six deck links by removing the hairpin clips and flat washers.
7. Disconnect the deck from the stabilizer plate assembly by removing the hairpin clips and flat washers and sliding out the rod.

8. Place the lift lever in the BLADES OFF position.
9. Slide the deck from beneath the lawn tractor.
10. Remove the left hand belt guard by removing the self-tapping screws.
11. Remove the right hand belt guard by removing the hex nut and flat washer.

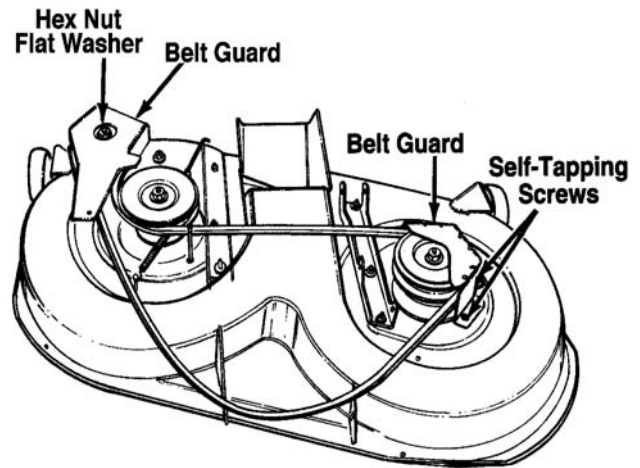


Figure 12-58. Deck Belt Assembly

12. Remove and replace the belt, reassemble following the instructions in reverse order.

# ATTACHMENTS

## Grass Collectors

OEM-190-601, OEM-190-602, OEM-190-821

### ASSEMBLY AND INSTALLATION:



The 601 twin bagger for 38" and 42" decks does not come with blades. Use the blades that came with the tractor.

1. Identify the pieces included in the carton. See Figure 12-59.



**Figure 12-59.**

2. Tilt the seat forward.
3. Position the hooked ends of the bracket assembly over the shoulder bolts located at the rear of the rider.
4. Insert the clevis pin through the bracket assembly and hitch plate and secure with hair-pin clip. See Figure 12-60.



**Figure 12-60.**

5. Place the cover assembly's support tube through the outer set of holes in the left side of the bracket assembly.



The inside holes are for units equipped with 46" decks.



The support tube needs to rest on the right side of the bracket assembly. Keep cover open while attaching the bags. See Figure 12-61.



**Figure 12-61.**

6. Hook grass bags into slots on cover assembly and close the cover.



The 821 bagger will come with three bags. See Figure 12-62.



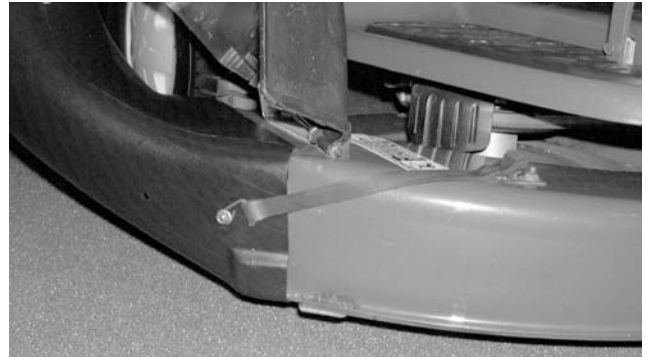
**Figure 12-62.**

7. Raise the deck to the highest cutting position and lift up the chute deflector. Place the top edge of the discharge chute over the opening on the deck. Push down on the discharge chute so that the front edge fits snugly around the deck opening. See Figure 12-63.



**Figure 12-63.**

8. Secure the discharge chute by hooking the retainer strap over the clip on the deck. See Figure 12-64.



**Figure 12-64.**

9. Insert the upper end of the chute tube into the hole in the cover assembly, then place the lower end of the chute tube over the discharge chute. Secure by placing the ends of the retaining straps on the discharge chute over the clips on the chute tube. See Figure 12-65.



**Figure 12-65.**



# FRONT BUMPER

OEM-190-603

1. Identify the different components.
2. Hook the notched ends of the bumper onto the shoulder bolts on the front of the tractor frame. See Figure 12-66.
3. Align the holes in the bumper with the holes in the tractor frame and insert the clevis pins. Secure with hairpin clips. See Figure 12-67



Figure 12-66.



Figure 12-67.

# TRAPAC

OEM-190-60A

1. Identify the different components.
2. Position the hooked ends of the bracket assembly over the shoulder bolts.
3. Insert the clevis pin through the holes in the bracket assembly and hitch plate. Secure the bracket assembly with the hairpin clip.
4. Pivot the seat forward. See Figure 12-68.
5. Slide the tool box onto the bracket assembly. See Figure 12-69.

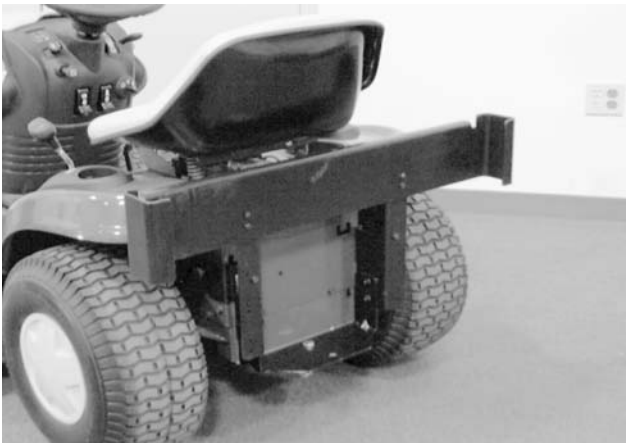


Figure 12-68.



Figure 12-69.

# 42" DOZER BLADE

OEM-190-620

## ASSEMBLY, INSTALLATION AND TROUBLESHOOTING

### ➔ NOTE

Prior to performing blade assembly and installation, it is recommended to remove the deck assembly.

### ➔ NOTE

These instructions are meant to be used along with those in the owners guide. Some steps have been modified to help simplify the process. Refer to the owners guide for hardware descriptions and locations.

### ➔ NOTE

Install hardware finger tight until instructed to tighten.



Figure 12-70.

1. Place the wear plate against the front edge of the blade and insert one carriage bolt in each end, head towards front of blade, and secure with hex lock nuts.

### ➔ NOTE

The wear plate is not reversible or adjustable. The skid shoes are adjustable (see adjustments section).

2. Place the reinforcement plate in position and insert four carriage bolts, head towards front of blade, through the blade and reinforcement plate. Secure with hex lock nuts.

3. Place the skid shoes against either side of the blade and insert the carriage bolts through the top holes of the blade and skid. Secure with flat washers and hex lock nuts.
4. Insert carriage bolts through wear plate, blade, and skid. Secure with flat washer and hex lock nuts. See Figure 12-71.
5. Insert hex bolts through blade, reinforcement plate, and front support bracket. Tighten carriage bolts and hex bolts securing wear plate and reinforcement plate using a 1/2" socket. See Figure 12-71.

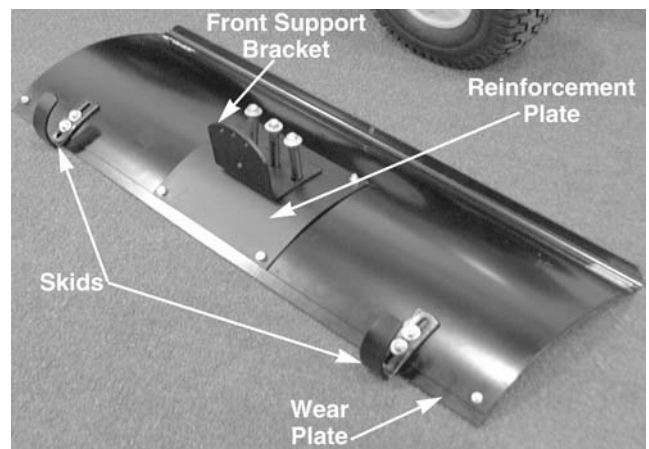


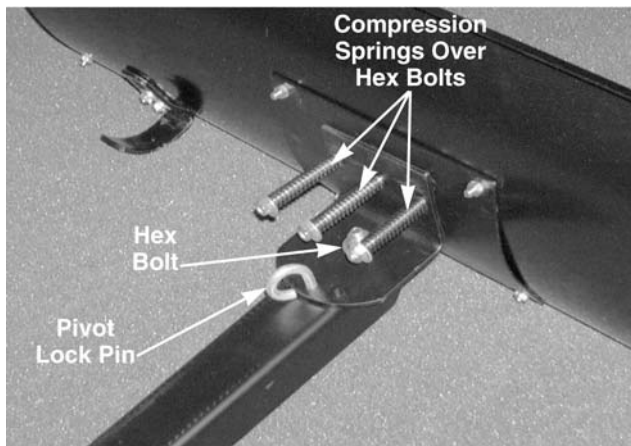
Figure 12-71.

6. Place compression springs over hex bolts and secure with flat washers and hex lock nuts. See Figure 12-71.
7. Insert hex bolt through push bar channel and front support bracket. Secure with flat washer and hex lock nut. Tighten using a 3/4" flat wrench on top and a 3/4" socket and 6" extension on the bottom. See Figure 12-72.

### ➔ NOTE

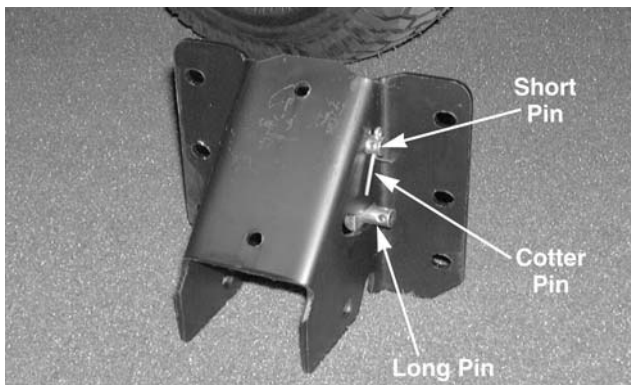
Do not overtighten the hex bolt because the push bar channel needs to pivot.

8. Insert the pivot lock pin through one of the holes in the front support bracket and push bar channel. Secure it with a hairpin clip. See Figure 12-72.



**Figure 12-72.**

9. Place the lift link inside the pivot support bracket. Insert the long pin through the slot in the support bracket and the short pin through the hole just above the slot.
10. Secure with lift link to the pivot support bracket with a cotter pin.



**Figure 12-73.**

11. Secure the support brackets to the frame in the rear holes with two .75" long hex bolts, lock washers, and hex nuts. Secure in the center and front holes with the 1" long hex bolts, lock washers, and hex nuts. Use a 1/2" socket to tighten the rear bolts and a 9/16" socket to tighten the middle and front hex bolts. See Figure 12-74.

**➡ NOTE**

The right and left hand support brackets are secured to the frame with four bolts behind the

pivot bar and one in front of the pivot bar. The support brackets angle inward.

**➡ NOTE**

The tractor tie rod will run between the two support brackets. When removing the attachment from the tractor it will be necessary to either lift the front of the tractor over the frame support brackets or remove the four hex bolts securing the upper and lower support brackets to the frame support brackets. See Figure 12-74.



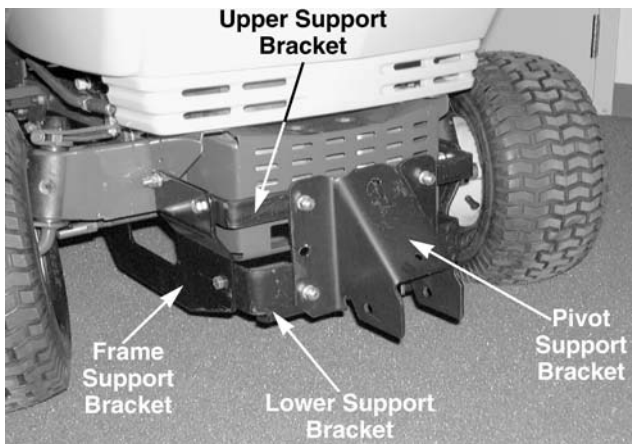
**Figure 12-74.**

12. Secure the upper and lower support brackets to the pivot support bracket with four hex bolts, lock washers, and hex nuts. Tighten using a 9/16" socket. See Figure 12-75.

**➡ NOTE**

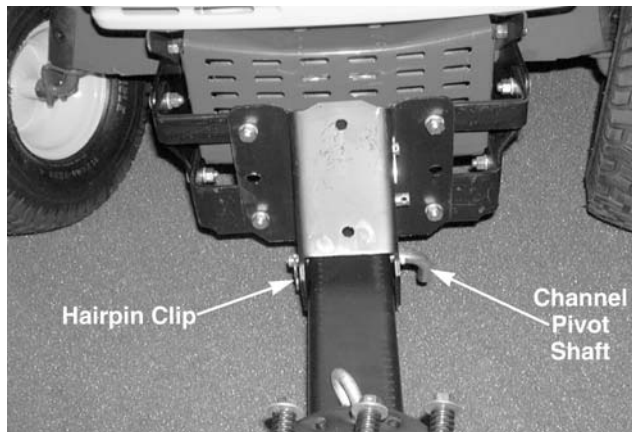
If the upper and lower support brackets contact the muffler heat shield, replace the brackets with kit number 753-0839. The brackets included in this kit will extend the attach hole distance from 1.25" to 2.25".

13. Secure the upper and lower support brackets to the frame support brackets with four hex bolts, lock washers, and hex nuts using a 9/16" socket. See Figure 12-75.



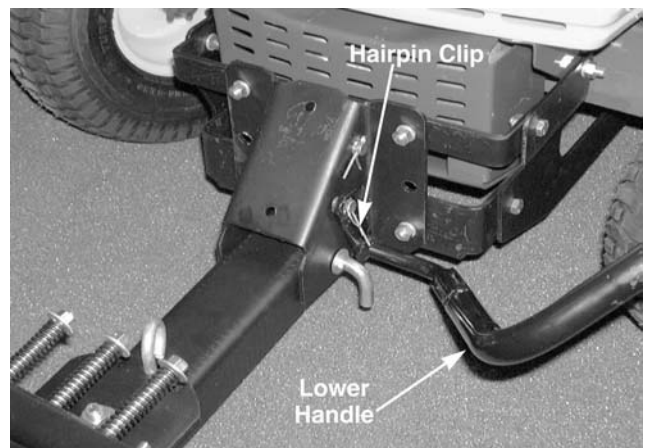
**Figure 12-75.**

14. Slide flat washer onto channel pivot shaft and insert the shaft through the holes in the pivot support bracket and push bar channel. See Figure 12-76.
15. Secure the channel pivot shaft with a hairpin clip. See Figure 12-76.



**Figure 12-76.**

16. Insert the end of the lower lift handle through the slot in the pivot support bracket and the hole in the push bar channel. The hole in the link on the end of the handle goes over the long pin on the lift link. See Figure 12-77.
17. Secure the lower handle with a hairpin clip. See Figure 12-77.

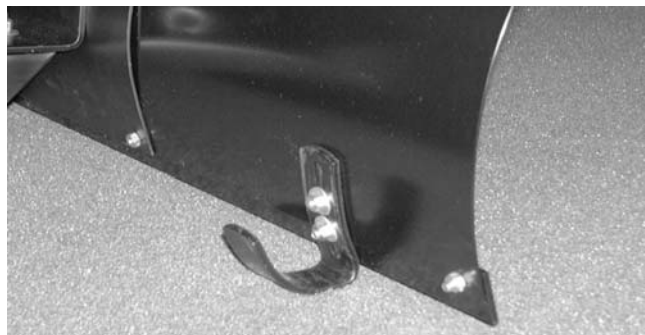


**Figure 12-77.**

18. Slide the grip onto the upper lift handle then secure it to the lower lift handle with the hex screw.

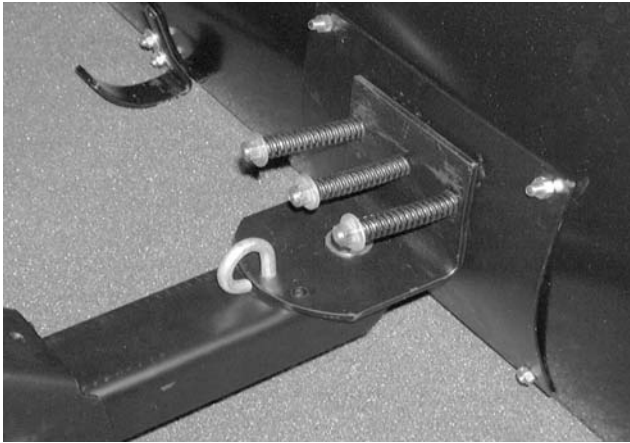
## Adjustments

1. Adjust the skid shoes so the wear plate is approximately 1/8" to 1/4" above the ground when the blade is fully lowered. Tighten the hex lock nuts securing the skid shoes to the blade using a 1/2" socket. See Figure 12-78.



**Figure 12-78.**

2. The normal adjustment for the spring tension is for the top of the hex nuts to be flush with the end of the hex bolts. To tighten the blade trip action, tighten the hex nuts using a 9/16" socket. See Figure 12-79.



**Figure 12-79.**

3. For the best blade performance, use with 62 lb. rear wheel weights, part number OEM 190-215, and tire chains (see chart below for correct chains for each tire size).

Part Number	Tire Size
OEM-190-657	18" x 9.5"
OEM-190-325	20" x 8.0"
OEM-190-664	18" x 6.5"
OEM-190-754	18" x 8.5"
OEM-190-915	20" x 10"

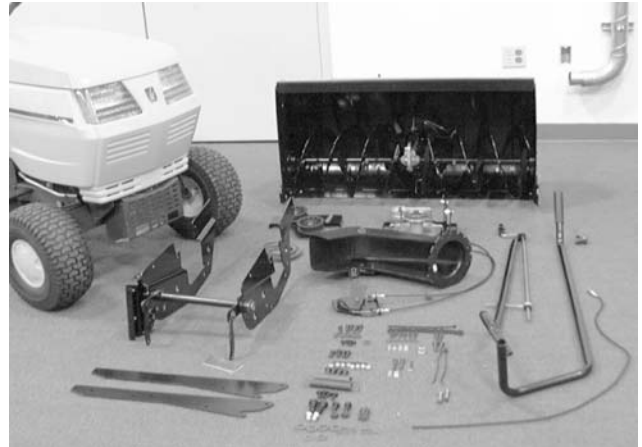
### ASSEMBLY, INSTALLATION, AND TROUBLESHOOTING

**➔ NOTE**

Prior to installing the snow thrower, it is necessary to remove the deck assembly and engine belt keepers.

**➔ NOTE**

These instructions are meant to be used along with those in the owners guide. Some steps have been modified to help simplify the process. Refer to the owners guide for hardware descriptions and locations.



**Figure 12-80.**

1. Secure the front of the support carriage to the frame using a 3/4" wrench and 3/4" socket.

**➔ NOTE**

Using a partner, lift the front of the tractor over the carriage assembly.

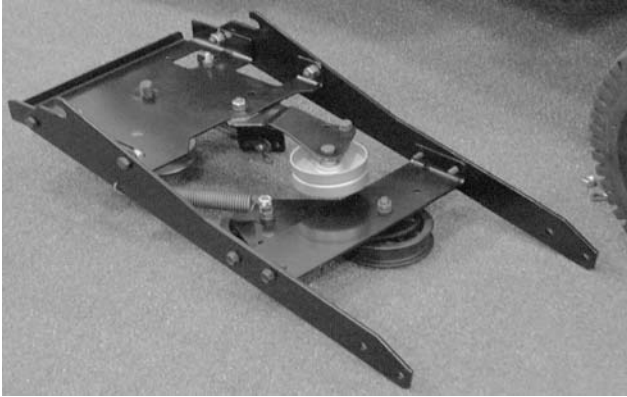
2. Secure the rear of the support carriage to the frame using a 1/2" wrench and 1/2" socket. See Figure 12-81.



**Figure 12-81.**

3. Insert hex bolt part way into the bottom hole of the grill mounting bracket (either side). Lift carriage assembly until it is against the bolt then tighten using a 1/2" wrench and 1/2" socket.
4. On top of the rear idler bracket assembly, loosen the left hex nut and remove the right hex nut using a 7/16" deep well socket.
5. Secure side plates to the rear idler bracket assembly using a 9/16" wrench and 9/16" socket.

6. Secure front idler bracket assembly to side plates using a 9/16" socket.
7. Attach extension spring between hex nuts on the flat idler, leaving slightly loose, and hole on right side plate. See Figure 12-82.



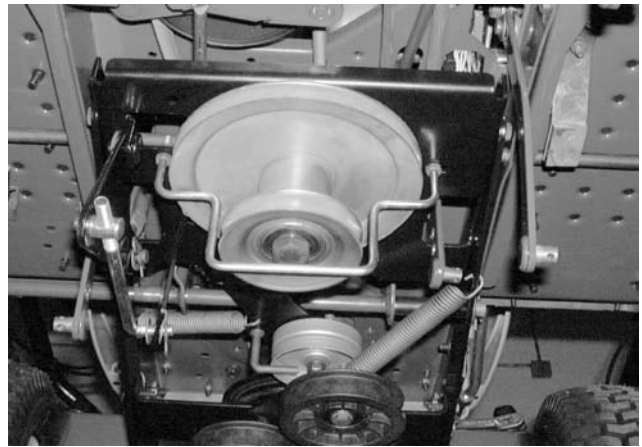
**Figure 12-82.**

8. Slide slots of side plates onto rod under tractor.

**➔ NOTE**

The front deck links must come through the slots of the rear idler bracket assembly. The ends of the side plates go inside the support carriage.

9. Secure the front of the side plates to the support carriage using a 9/16" socket.
10. Remove the control rod from the idler bracket by removing the hairpin clip. Lower the engagement lever to the lowest position.
11. Thread the adjustable lift link all the way up and insert the adjustable lift link into the hole in the idler engagement bracket. Secure with the hairpin clip from the deck assembly. See Figure 12-83.



**Figure 12-83.**

12. Insert the control rod into the idler bracket and secure with hairpin removed in step 10.
13. Tilt auger housing forward and roll the tractor up to the housing. Line up the hole in the small lift link on the support carriage with the hole in the bottom lift link. Insert lift pin through both holes and secure with cotter pin.
14. Line up the hole in the bottom lift link with the bottom rear hole in the support carriage. Place flat washer over hex bolt and insert into hole. Place other flat washer on hex bolt. Secure with slotted nut. Using a 1/2" wrench, tighten slotted nut until snug, then back off approximately 1/3 turn or until one of the slots in the slotted nut lines up with the hole in the bolt.
15. Insert the cotter pin through the slot in nut and hole in bolt. Secure with cotter pin.
16. Place hex bolt through hole in top link and hole in support carriage. Secure with hex lock nut using a 1/2" socket and 1/2" wrench.

**➔ NOTE**

Make certain the hex nut is loose enough to allow the top link to pivot.

17. Lubricate the snow thrower chute opening.
18. Loosen the two hex nuts on the chute crank spiral bracket using a 1/2" wrench.
19. Place discharge chute over chute opening of snow thrower housing with the opening in the discharge chute facing forward. Line up the spirals of the chute crank with the notches in

the discharge chute. Place the chute flange keepers beneath flange discharge chute, and insert hex bolts up through chute flange keepers and discharge chute flange. Secure all three flange keepers finger tight with lock nuts, then tighten using a 7/16" socket and 7/16" wrench.

**➔ NOTE**

Leave lock nuts loose enough to allow easy turning of discharge chute.

**➔ NOTE**

Make sure the hex lock nuts securing the upper chute to the lower chute are not over-tightened. This could cause the plastic tab within the cable guide, for the chute tilt control, to break where the barrel on the end of the cable fits into the plastic retainer.

20. Install chute crank support tube and rod on left top link of snow thrower support tube and secure with carriage bolts, washers, and nuts using a 1/2" socket and 1/2" wrench.
21. Remove chute crank rod.
22. Place chute tilt handle assembly on support tube and secure with carriage bolts, washers, and flange lock nuts using a 1/2" socket.
23. Secure cables of chute tilt handle assembly to support tube using cable tie.
24. Insert end of chute crank rod into universal joint and secure with cotter pin.

**➔ NOTE**

It may be necessary to pull back on chute rod to line up end of chute rod with the universal joint.

25. Line up chute crank spirals with notches in chute and tighten nuts on chute crank spiral bracket using 1/2" wrench.
26. Place lift handle into lift handle mounting bracket on the right side of snow thrower support. Line up holes on lift handle and mounting bracket and secure with hex bolts and lock nuts using a 1/2" socket.
27. Place "Z" end of pivot release cable into hole of lift latch. Loosen nuts on cable and place cable

into slot of mounting bracket with one hex nut above the slot and one lock washer and hex nut below. Tighten finger tight. See Figure 12-84.



**Figure 12-84.**

**➔ NOTE**

To release the latch when raising or lowering the snow thrower, push down on the lift handle before squeezing the trigger assembly. This will take the pressure off of the pivot release cable and prevent any damage to the cable or trigger assembly. See Figure 12-85.



**Figure 12-85.**

28. Thread the release cable through the trigger assembly.
29. Slide the flat weld nut into the trigger housing.
30. Hold flat weld nut in position, place the trigger assembly against the lift handle, secure with truss machine screw.



- Secure pivot release cable to lift handle using two cable ties.

#### INSTALLING THE BELTS:

- Pivot the belt guard to the left. See Figure 12-86.

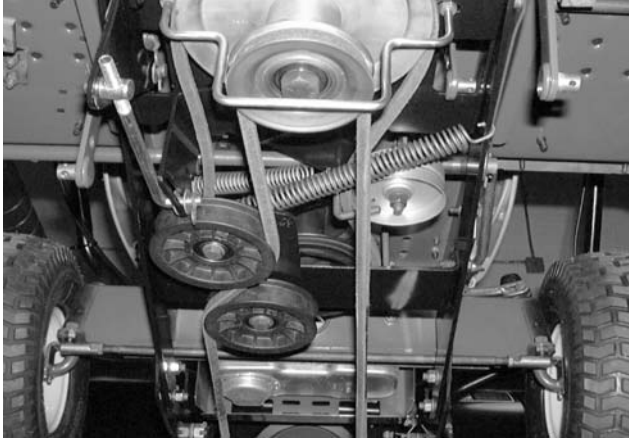


Figure 12-86.

- Loosen the belt keeper and work the belt past the keeper and onto the engine pulley, idler pulley, and top pulley on the idler bracket assembly.
- Lower the snow thrower to the ground.
- Route the long belt, or auger belt, around the auger pulley.



Figure 12-87.

- Loosen the nuts that secure the belt guards to the front idler bracket using a 1/2" wrench.
- Route the belt around idler pulleys and bottom pulley on rear idler bracket assembly. See Figure 12-88.

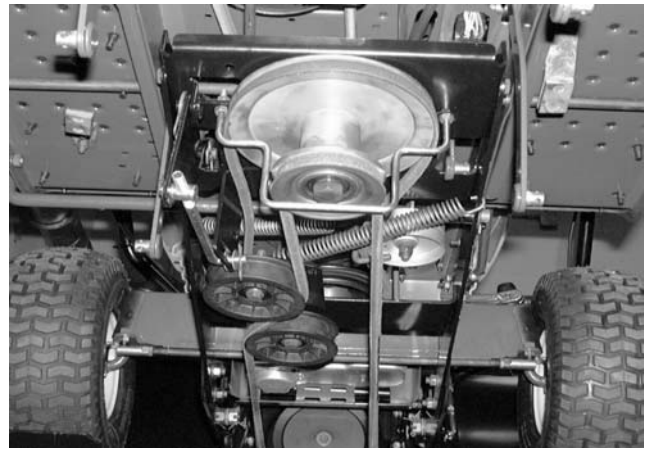


Figure 12-88.

#### NOTE

The flat side of the belt goes against the idler pulley. See Figure 12-89.

#### NOTE

The auger belt may "whip," come free, or wear prematurely from rubbing on the edge of the "v" idler. To correct this, replace the v idler with plastic flat idler part #756-0627. As of 1999 both idlers are flat idlers. This keeps the belt from rubbing and allows for better alignment of the auger belt between the double pulley and the two front "v" idler pulleys. The routing of the belt stays the same with the narrow "v" side of the belt traveling on the left of the rear flat idler and the wider flat side of the belt traveling on the right side of the front flat idler.

#### NOTE

The auger belt might "whip" or come free. The belt originally used in production in 1996 was part number 754-3039 and was 103" long. The belt currently being used is part #754-0455 and is 102" long. In 1996, tension was kept on the auger belt with an extension spring that ran from the frame to a "v" idler arm assembly on the front left side of the attachment. In October of 1997 this extension spring was eliminated (reference service kit 753-0716) and tension was changed to the current production design. When installing the kit, also use belt number 754-0455, 102" long.

#### NOTE

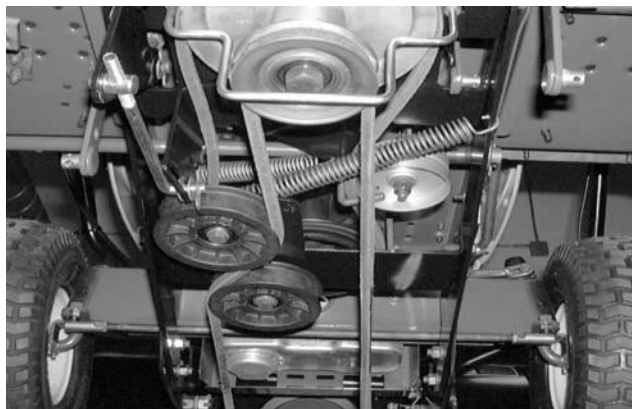
During 1997 and 1998 production, three spacers, part number 711-0242, were installed



between the idler support bracket and the idler pivot arm. This was to allow for movement of the belt as the snow thrower was raised and lowered. The spacers attempted to even the plane between the double pulley and two front "v" idlers. With current production now using two flat idlers on the pivot arm, only one spacer should be used instead of three.

38. Place extension spring into hole in idler bracket and, using a short piece of rope, into hole in left frame (just behind left support carriage bracket).

39. Reinstall all belt keepers and belt guard. See Figure 12-89.

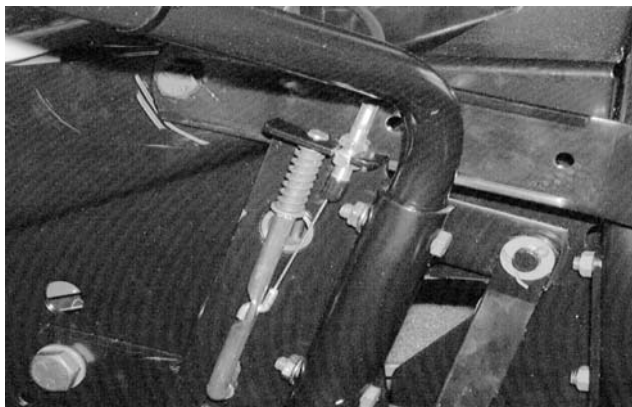


**Figure 12-89.**

#### **ADJUSTMENTS:**

##### **Pivot Release Cable:**

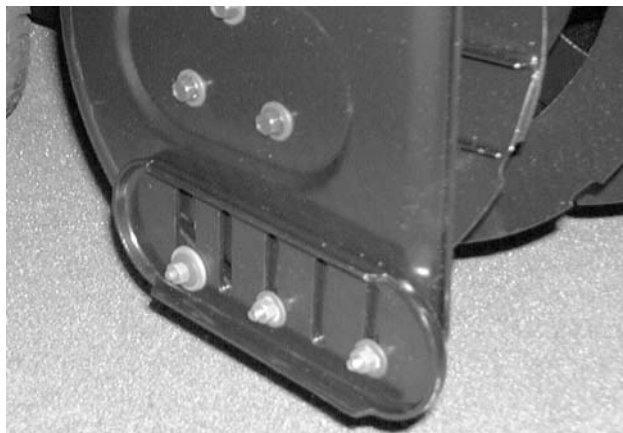
Squeeze trigger on trigger assembly. If lift latch does not latch securely, loosen upper hex nut several turns and tighten lower hex nut using two 1/2" wrenches. If pivot release cable has slack in it, loosen lower hex nut several turns and tighten upper hex nut. If lift latch is already latched securely, tighten the lower hex nut. See Figure 12-90.



**Figure 12-90.**

##### **Skid Shoes:**

Raise auger housing off the ground and loosen the six hex nuts securing the skid shoes to the housing using a 9/16" wrench. Lower the housing onto a piece of cardboard and tighten skid shoes so they are touching the ground. See Figure 12-91.



**Figure 12-91.**

##### **Disengagement (manual pto):**

Remove the control rod from the idler bracket assembly by removing hairpin clip and washer. Thread control rod out of ferrule a few turns. Reinstall control rod and test engagement. See Figure 12-92.



**Figure 12-92.**

## NOTES

---

---

---

---

---

---

---

---

---

---

---

---

---

---

---

---

---

---

---

---

---

---

---

---



# POWER EQUIPMENT DICTIONARY

## MOWER TERMS:

**Full Baffled Housing:** A front and rear welded housing underneath the deck to create an entire circular deck. This increases the air flow to effectively discharge grass.

**Blade Lift:** A raised area, behind the cutting tips, which creates a lift and pulls the grass up to the blade. The proper lift is more important to the cutting quality than even a sharp edge.

**Vacuum Lift Action:** This is created by a combination of a baffled deck design and the rear lift of the blade. The deep vacuum action lifts the grass for cleaner, sharper cutting and efficient discharge.

**Cloth Catcher:** These wide-mouth easy dump catchers offer superior bagging performance because of excellent air flow during cutting and allow for maximum fill of the catcher.

**Hard Top Catcher:** More durable than cloth-type is vented downward and drives its dust into the grass instead of the operator. The hard plastic top provides durability, stability and balance.

**Hi-Vac Deck:** For excellent cutting and bagging performance. Brings grass into catcher from top thus creating better air flow plus easy bag fill.

**Steel Housing:** Sheet steel, stamped and formed into a housing configuration (won't crack or chip).

**Cast Aluminum Deck:** Lightweight and easy to maneuver. Aluminum provides a no rust material extended unit life.

**Rolled Deck (Tapered):** Bottom edge of steel housing is rolled under the inside for better control of grass flow and cutting, additional strength, won't snag or damage shrubbery.

**9-Position Individual Height Adjustment:** A lever at each wheel allows setting height of cut for taper cuts, cut trimming, and cutting extra high grass. The rear wheels should be set one notch higher than the front for extra high grass conditions.

**Single Lever Height Adjuster:** Adjusts all four wheels with one lever. This spring loaded system is our most convenient and easy to operate height adjust system. Synchronized all wheel adjustment.

## CPSC Mandatory Blade Safety Standards:

Since July 1, 1982, all manufacturers produce only mowers that comply with the Consumer Products Safety Commission mandatory requirements. Basically, the blade must stop (either with the engine continuing to run or stopping) within 3 seconds of the user releasing a handle-mounted control. There are three acceptable alternatives:

1. **Extended Rope Start, or Manual Restart (ERS):** When user releases handle control, blade and engine stop within 3 seconds. To start or restart, operator must engage handle control and pull starter rope, which is mounted on the handle.
2. **Battery/Electric Start (EAS):** Self recharging battery start eliminates manual type starting. Simply engage handle controls to start. Engine and blade stop when handle control is released. An alternator recharges the battery as mower is being used. Starter normally requires recharging only first time each season and prior to winter storage. 110 volt recharger included.
3. **Blade Brake Clutch (BBC):** When user releases handle control, blade stops within 3 seconds but engine continues to run. Requires starting the engine only once.

**Rear Drive:** A multi-speed drive system. Changing drive speeds is made easy by fingertip controls located on the upper handle. The operator maintains full traction/drive control without letting go of the handle.

**Internal Rear Belt to Gear/Chain Drive:** An enclosed system to power-propel the mower where power is transferred to both drive wheels from the engine through a belt to a geared transmission.

**Rear Baggers:** Rear bag catchers allow grass cutting closer to fences, buildings, trees and shrubs from either side of the mower, and can get into narrower areas.

**Cog Drive:** Plastic pinion that engages cog tire. Convertible Mower: Converts from rear bagging to side discharge style mower. Gives the versatility of two mowers in one. If a mulching kit is available the mower would be a three-in-one.

**Convertible Mower:** Converts from rear bagging to side discharge style mower. Gives the versatility of two mowers in one. If a mulching kit were available the mower would be a three-in-one

**Deluxe Throttle Control:** Allows operator to set engine speed without slipping out of position. Has ratchet-setting throttle adjustment. Handle-Mounted Clutch: Makes engagement of self-propelled mechanism easier. Engages self-propelled mechanism with one hand.

**Handle-Mounted Clutch:** Makes engagement of self-propelled mechanism easier. Engages self-propelled mechanism with one hand.

**Internal Drive:** Results in better straight line cutting with less fatigue. Propels chain internally to rear axle.

**Knurl Drive:** Provides positive control and good traction on wet grass while mowing uphill without clogging. Steel pinion engages a smooth tire.

**Steel Ball Bearings Wheels:** Provides easier maneuverability while operating unit. Steel bushing is comprised of steel bearings. Promotes longer life.

**Self Starter:** Mechanical device that runs of the recoil spring. No battery or electric cords required.

## **Tractor Terms**

**Auto Drive:** Foot pedal drive control that drives like a car.

**Austempered Steel Blade:** A special heat treated process which increases life, durability, and keeps steel from being brittle.

**Clutch/Brake Pedal:** Eliminates the need for two pedals. Synchronized clutch and brake on one pedal.

**Zero-Turn:** Extremely tight turning radius

**In-Line Shift:** Makes shifting gears easier. Straight-line pattern.

**Transmatic:** Combination of transaxle and multi-speed drive means effortless, no clutch on the go shifting with virtually an infinite number of speeds available between high and low.

**Hydrostatic Transmission:** System which utilizes a self lubricating oil propulsion design mounted on

a hydrostatic drive transmission. Hydrostatic drives hold preset constant speeds even on hills and uneven terrain. Eliminates clutching for safer operation. Changing forward/reverse direction without clutching.

**4-Wheel Steering (All Wheel Steer):** Provides maximum maneuverability by allowing all four wheels to turn while steering. Permits near hair-pin turns, the tractor neatly pivots to allow close trimming around small areas. Allows more stability on slopes, less turf defacement in tight turns.

**Pivoting Front Axle:** Center mounted pivot on rear engine riders, lawn tractors and garden tractors which provides better stability. The pivoting action acts like an automotive shock absorber which allow the wheels to adjust to uneven ground contour while maintaining an even uniform cut. Helps prevent scalping.

**Ammeter:** A gauge that shows whether the battery is being charged (+) or discharged (-).

**Belt PTO:** PTO stands for power take-off. A belt is the driving force to whatever is to be driven.

**Electric Assist:** Allows the customer to raise or lower attachments by just a flip or a switch.

**Floating Deck:** Instead of being bolted rigidly to the tractor, the deck is mounted so that it will move up and down with the contour of the lawn to prevent scalping and insure an even cut.

**Hour Meter:** Records the running time of the tractor. Also called Hobbs meter. Should be used in conjunction with the maintenance schedule in the owner's manual.

**Height Adjustment with Memory:** Use the height control lever to set the cutting height you want. Set the memory latch. Then, each time you go out to cut grass and lower the mower, it will be the same height until you change it.

**Manual Hitch:** A hitch system that is operated manually. Takes more effort to raise attachments than the electric assist system.

**Single Lever Lift System:** Tractor comes with lift lever that will raise and lower certain attachments, including the mower deck and snow/dozer blade, reducing operator effort.

**PTO (Power Take Off):** A means of powering an attachment using a belt, with the engine as a power source.

**Gear and Pinion Steering:** A very smooth type steering where a gear on the end of the steering shaft meets another gear called a sector gear. Reduces steering effort compared with conventional steering.

**Shift-on-the-Go:** A shifting system where you do not have to push in the clutch every time you change speeds. You simply move the shift lever from one gear to another.

**Sleeve Hitch:** Used on garden tractors. After mounting hitch to tractor, attachments mount to the hitch with a single pin.

**3 Point Hitch:** Used on garden tractors. After mounting hitch, attachments mount to hitch at three points.

**Rear Engine Rider:** Used strictly for mowing and some lawn care. You can use light weight pull attachments. Will not accept snow removal equipment. Offers excellent frontal visibility.

**Lawn Tractor:** Used for lawn care, but will also take snow removal equipment such as a snow blade and snow thrower.

**Garden Tractor:** Will accept ground engaging equipment, such as a plow. It will also take the large pull-type attachments. Usually contains heavy duty transmissions for stamina in towing and other chores.

**Transaxle:** A gear box that combines both the transmission and differential in the same housing. Driven by a belt rather than a chain (as used on a transmission). Usually has larger gears for heavier jobs.

**Transmission:** A gear box with a separate drive chain that drives a differential attached to rear wheels.

**Turf-Saver Tires:** Won't skid in the grass, thus improving traction and helping to avoid scuff marks on the lawn.

**Turning Radius:** When making a hard left turn with mower engaged, the amount of uncut grass when the circle is complete. Take 1/2 the diameter, and that would be the turning radius.

**Universal Hitch Pin:** 1/2 inch diameter for use with all tractors and riders.

**Clutch/Brake Pedal:** Eliminates the need for two pedals. Synchronized clutch and brake on one pedal.

## MISC. TERMS

**Bolo Tines:** Provides better tine wear in hard or rocky soil. Steel tines are heat treated.

**Flails:** "Free floating" steel hammer knives, sharpened on all edges to cut and pulverize. Chipper Shredder component.

**MPH:** Miles per hour speed of air flowing out of the unit.

**CFM:** Cubic feet of air per minute flowing out of the blower chute. This is a better measure of blower effectiveness. High MPH can be generated through a straw, but CFM, or volume of air per minute, is more indicative of the units ability to move objects.

**Curb-Hopping:** Adjustable front wheels and curb-hopping rear wheel allow the edger to be used with stability close to raised curbs.

**Edging Depth:** The edging depth in inches, that the blade can trench.

**Chain Drive:** Provides more direct power to the tines. Stamped chain case that is permanently lubricated.

**Depth Bar:** Allows full control during operation. Adjusts tilling depth.

**Dual Direction Tines:** Tines move in either forward or reverse direction for optimum tilling in either hard or soft soil.

**Gear Drive:** Provides extra weight for deep tilling and lower center of gravity for greater stability. Gear case constructed of rugged cast iron of galvanized steel.

**Reverse Direction Tines:** Provides greater stability when tilling and eliminates skipping. Tines rotate in the opposite direction from the drive wheels. Also known as counter rotating tines.

**Differential Gear:** A certain arrangement of gears connecting two axles in the same line and dividing force between them, allowing one axle to turn faster than the other. It is used in the rear axles of

automobiles to permit a difference in axle speeds while turning curves.

**Bushel:** One bushel equals 8 gallons.

**Gasoline:** We recommend regular unleaded gas. Do not leave gas in tank over the winter unless fuel stabilizer is used; start each season with fresh gas (don't use fuel that is over 4 months old). DO NOT USE Gasohol that is more than 10% alcohol or methanol.

**Oil:** Use SAE 30 or 10W-30 weight detergent oil (not 10W-40). It is very important to change oil after the first two hours of use in a new mower and then after every 25 hours of operation. Always consult owners guide for fill capacity.

**Fuel Stabilizer:** For all 2 and 4 cycle engines this product allows for easy starts when put in full tank of gas and stored during long periods of time.

**Cutting Height:** It's not recommended to cut off more than the upper third of the grass at one cutting. In most grasses the cutting height should be lower in the cool spring, higher in the hot weather in heavily shaded areas.

**Mowing Direction:** During cutting, mow in a counter-clockwise manner to prevent clippings from being recycled into the cutting path. The cutting blade isn't forced to pick up wet clippings as it mows the uncut grass. If mower wheels compact the soil, leaving tracks, alternate the mowing pattern each time you mow.

**Collecting Clippings:** Heavy clippings left on the lawn can smother the grass, preventing needed air and moisture from reaching the roots. Clippings harbor lawn insects, disease, fungi, and are unsightly. Mulching mowers do not cause this problem since the grass clippings are cut finely and return nutrients to the soil.

**Spark Plug:** Should be changed every spring for easier starting and engine efficiency.

**Air Filter:** Replace the air filter every year, more often if needed. This helps the engine start easier, run better, last longer and uses less gas.

**Mower Blade:** Worn blades should be replaced, not only for the new cutting edge but also for the lift designed into it that restores air turbulence. A worn blade won't cut well or bag, causes engine vibration, and loss of power.

## ENGINE TERMS

**Automatic Choke:** Method of automatically priming the carburetor for surer starts.

**Automotive Type Air Filter (Paper Type):** A larger filter area (90 sq. inches) than conventional oil bath sponge filters. Will last longer and does a better job keeping engine running cleaner, enhancing engine life. Requires little or no maintenance. For dusty/sandy areas, a washable/reusable pre-cleaner is available to extend the life of the paper air filter.

**Cast Iron Cylinder Liner:** Provides better oil retention and superior wear. Dissipates heat more efficiently for longer engine life and lower maintenance cost.

**Mechanical Governor:** Internal flyball weights on the crankshaft automatically call for more fuel to increase the engine's output when more power is needed, for example, cutting thick, tall grass, helping to keep blade speed constant.

**Mechanical Compression Release:** A mechanical device which acts on the camshaft to greatly reduce internal air pressure during the starting cycle, significantly reducing the effort required to start the engine. It closes automatically during engine operation to retain full power.

**Operator Zone:** The area behind the handle where the user must be positioned when he operates the mower.

**Overhead Valve Engine:** Valves are located in the head of the engine rather than in the cylinder block itself. This enables the engine to develop more torque (power) than a conventional "L-head" engine with similar cubic inch displacement. It allows the engine to run cooler and more efficiently for longer life.

**Polymer Gas Tank:** Prevents rust and condensation in the fuel system.

**Positive Lubrication:** Oil is pumped to vital engine parts when the engine is started. Lubricates the engine with each turn of the crankshaft.

**Horsepower:** Horsepower is a technical term referring to the rate at which an engine can perform work. The larger the horsepower rating of an engine, the greater is its ability to handle the job.

**Solid State Ignition:** Solid state circuitry eliminates points and condensers in conventional ignition systems, which become less efficient and wear

out. A self-contained module eliminates moving parts. In addition, it creates a hotter spark for more dependable starting. Eliminates costly electrical tune-ups. Simply change the spark plug.

**Top Breather:** Prevents oil overflow and maintains lubrication of vital parts when mowing alongside steep grades in either direction at any safe angle.

**Muffler Deflector:** Protects operator. Deflects the exhaust away from the operator.

**Extended Oil Fill:** Makes it easier to add oil to engine. Long tube extends to top of engine. Many extended oil fills feature automotive style dipstick.

**Industrial Commercial Engine:** Features rugged cast iron sleeves, heavy-duty dual element air cleaner, and heavy duty valves for extended engine life.

**Pre-Cleaner For Air Filter:** Is recommended in dusty, sandy conditions, and extends the life of the air filter, more economical.

**Spark Plug Boot:** Keeps spark plug clean and protects the engine from shorting out when contact is made with shrubs or trees. Rubber boot completely covers spark plug.

**Counter-Balanced Engine:** Counterweights are added to the crankshaft of the engine so that when the piston moves in one direction, the counterweight moves in the opposite direction, reducing vibration for smoother running.

**Displacement:** As with automobiles, the only way to accurately compare their various engines is to compare their various displacements. The displacement of an engine is measured in cubic centimeters of cubic engines. Displacement is the measure of the difference in cubic area of the cylinder when the piston has been fired all the way down and when it is all the way up. It is the area in which the explosion is made. Thus, the greater this area, the more power is generated.

## TERMS FOR HYDROSTATIC TRANSMISSIONS

**Axial Piston:** Type of design for hydraulic motors and pumps in which the pistons are arranged parallel with the spindle (input or output shaft).

**Bantam Duty:** A descriptive term relating to the product capacity (meaning: light duty).

**Bypass Valve:** A valve whose primary function is to open a path for the fluid to bypass the motor or pump. Also referred to occasionally as the free-wheel valve or dump valve.

**Case Drain Line (Return Line):** A line returning fluid from the component housing to the reservoir.

**Cavitation:** A concentrated gaseous condition within the fluid causing the rapid implosion of a gaseous bubble.

**Center Section:** A device that acts as the valve body and manifold of the transmission.

**Charge Pump:** A device that supplies replenishing fluid to the fluid power system (closed loop).

**Charge Pressure:** The pressure at which replenishing fluid is forced into a fluid power system.

**Charge Relief Valve:** A pressure control valve whose primary function is to limit pressure in the charge circuit.

**Check Valve:** A valve whose primary function is to restrict flow in one direction.

**Closed Loop:** A sealed and uninterrupted circulating path for fluid flow from the pump to the motor and back.

**Decay Rate:** The ratio of pressure decay over time.

**End Cap:** See "Center Section"

**Entrained Air:** A mechanical mixture of air bubbles having a tendency to separate from the liquid phase.

**Gerotor:** A positive displacement pump frequently used as a charge pump.

**Hydraulic Motor:** A device that converts hydraulic fluid power into mechanical force and motion by transfer of flow under pressure.

**Hydraulic Pump:** A device that converts mechanical forces and motion into hydraulic fluid power by producing flow.

**Hydrostatic Transaxle:** A multi-component assembly including a gear case and a hydrostatic transmission.

**Hydrostatic Pump:** See "Hydraulic Pump"



**Hydrostatic Transmission:** The combination of a hydraulic pump and motor in one housing to form a device for the control and transference of power.

**Inlet Line:** A supply line to the pump.

**Integrated Hydrostatic Transaxle (IHT):**  
The combination of a hydrostatic transmission and gear case in one housing to form a complete transaxle.

**Manifold:** A conductor that provides multiple connection ports.

**Neutral:** Typically described as a condition in which fluid flow and system pressure is below that which is required to turn the output shaft of the motor.

**Pressure Decay:** A falling pressure.

**Priming:** The filling of the charge circuit and closed loop of the fluid power system during start up, frequently achieved by pressurizing the fluid in the inlet line.

**Purging:** The act of replacing air with fluid in a fluid power system by forcing fluid into all of the components and allowing the air a path of escape.

**Rated Flow:** The maximum flow that the power supply system is capable of maintaining in at a specific operating pressure.

**Scoring:** Scratches in the direction of motion of mechanical parts caused by abrasive contaminants.

**Swash Plate:** A mechanical device used to control the displacement of the pump pistons in a fluid power system.

**System Charge Check Valve:** A valve controlling the replenishing flow of fluid from a charge circuit to the closed loop in a fluid power system.

**System Pressure:** The pressure that overcomes the total resistance in a system, including all losses.

**Valve:** A device that controls fluid flow direction, pressure, or flow rate.

**Variable Displacement Pump:** A pump in which the displacement per cycle can be varied.

**Volumetric Displacement:** The volume for one revolution.



***MTD SERVICE LLC***

P.O. Box 361131 • Cleveland, Ohio 44136-0019