

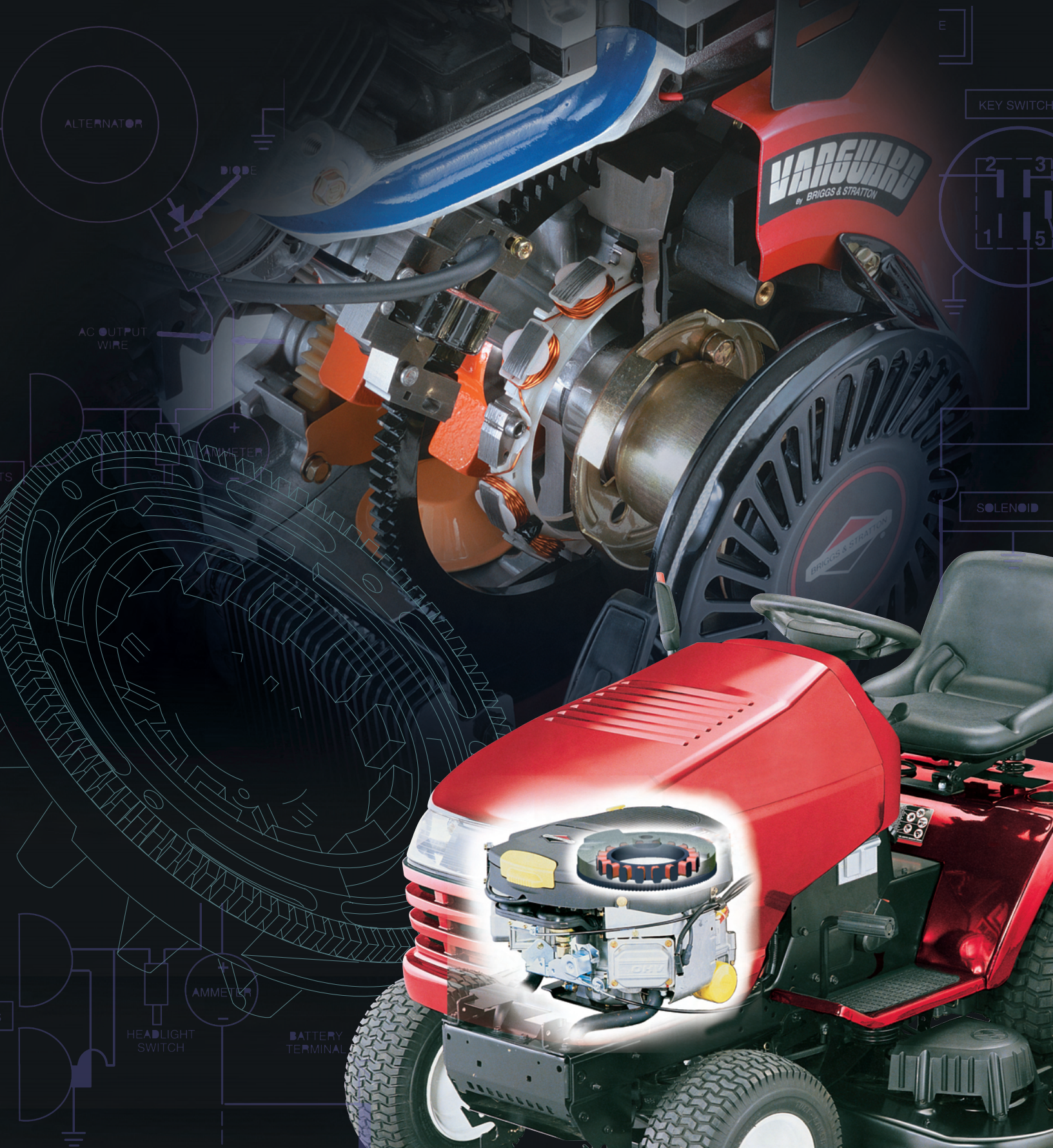

Customer Education

ENGINE ALTERNATOR REPLACEMENT GUIDE



ALTERNATOR

DIODE

AC OUTPUT WIRE

VOLTMETER

AMMETER

HEADLIGHT SWITCH

BATTERY TERMINAL

KEY SWITCH

SOLENOID

ThePowerPortal.com

Your "One Stop" Information Source

Briggs & Stratton has developed a powerful and flexible private web-based portal for its family of products, ThePowerPortal.com.

POWER PORTAL FEATURES

- Secure, on-demand, 24x7 access to meaningful information and functions for all of our products.
- Role-based security that will dynamically generate an interface and content which is specific to the various roles of the user.
- Interact via the internet for a variety of business transactions.
- Here is a glimpse of the available features on the brands for which you provide sales and/or service for.

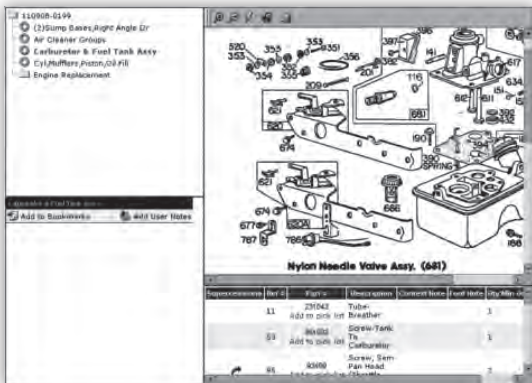

- Brand specific product registration & rebate submission
- Eclaim - electronic warranty claim filing for engines and end products
- E-parts - service parts and/or whole goods look-up and ordering
- Tech press search
- Re-powering and replacement engine look-up
- 1,000s of technical and service documents

Use Briggs & Stratton Genuine Parts

Briggs & Stratton engine warranty does not cover engine damage caused by non-original parts. Briggs & Stratton recommends the use of genuine Briggs & Stratton parts for warranty claims.



- **IDENTICAL GENUINE PARTS ARE USED IN MANUFACTURING BRIGGS & STRATTON ENGINES**
- **GENUINE PARTS ARE ENGINEERED AND TESTED FOR EXACT FIT AND PERFORMANCE**
- **1-YEAR LIMITED WARRANTY ON ORIGINAL PARTS (USA-CANADA ONLY)**

Table of Contents

Continuity Checks - Switches $\rightarrow + \text{)))$	2
DC Voltage Battery Test $v \text{ ---}$	2
Resistance Checks Ω	2
Diode Checks $\rightarrow + \text{)))$	3
DC Shunt	4
How Does A Shunt Work?	4
Ohm's Law Formula	5
DC Shunt Instructions	7
No-Load Starter Current Draw 12 Volt Starter Motors $300mV \text{ ---}$	8
Starter Current Draw – 12 Volt Starter Motors $300mV \text{ ---}$	9
AC Voltage Output Check $v \sim$	10
DC Amperage Output Check $A \text{ ---}$	11
Checking DC Amperage Output	12
16 & 20 Amp Regulated Alternator	12
Starter Motor Current Draw 120 Volt Starter Motors $A \sim$	13
Electric Starter Kits Quick Reference	14
Alternator Identification	15
Engine/Alternator Replacement Information	17
Replacing Briggs & Stratton Engines	17
Briggs & Stratton Engine Replacing Engine Of Another Manufacturer	21
Performance Control™ Electronic Governor	40
AWG Wire Sizes	41
Metric Wire Gauges	41
Load Carrying Capacities	41
Glossary of Terms	44

CONTINUITY CHECKS - SWITCHES \rightarrow Ω

1. Insert RED test lead into $v \Omega \rightarrow$ receptacle in meter.
2. Insert BLACK test lead into **COM** receptacle in meter.
3. Rotate selector to \rightarrow Ω position.
4. When meter test leads are attached to switch terminals and switch is in "ON" position, a continuous \rightarrow tone indicates continuity. With switch in "OFF" position, no tone indicates no continuity (incomplete circuit). An incomplete circuit will be displayed as "OL".

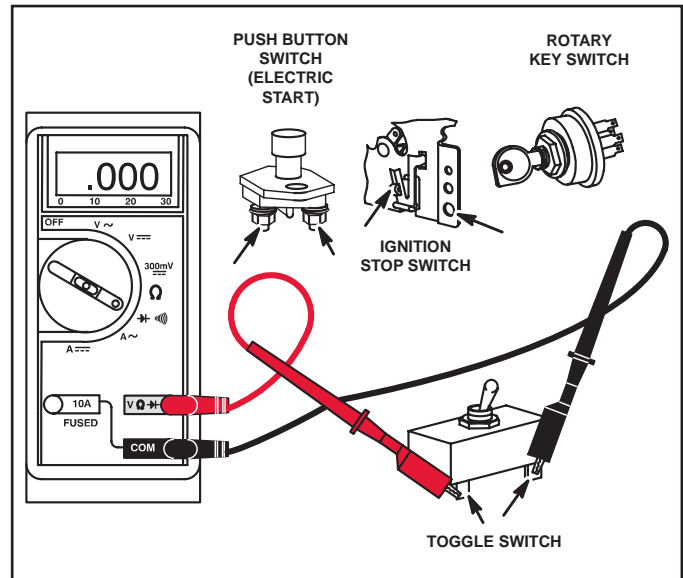

Continuity Checks

DC VOLTAGE BATTERY TEST $v \text{---}$

1. Insert RED test lead into $v \Omega \rightarrow$ receptacle in meter.
2. Insert BLACK test lead into **COM** receptacle in meter.
3. Rotate selector to $v \text{---}$ position.
4. Connect RED test lead to + (positive) terminal on battery and BLACK test lead to - (negative) terminal. Battery voltage can be checked as shown.

Battery posts, terminals and related accessories contain lead and lead compounds, chemicals known to the State of California to cause cancer and birth defects or other reproductive harm. WASH HANDS AFTER HANDLING.

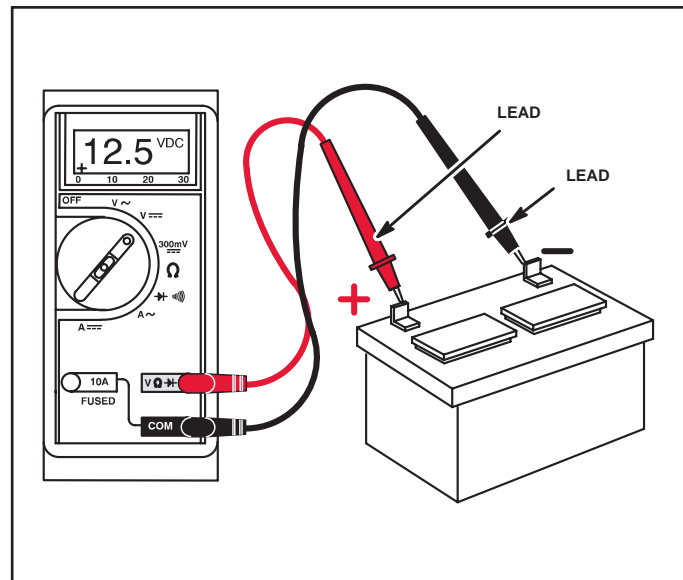

DC Voltage Battery Test

RESISTANCE CHECKS Ω

1. Insert RED test lead into $v \Omega \rightarrow$ receptacle in meter.
2. Insert BLACK test lead into **COM** receptacle in meter.
3. Rotate selector to Ω position.
4. Attach test leads to component being tested.
5. Meter will display amount of ohms resistance in component being tested.

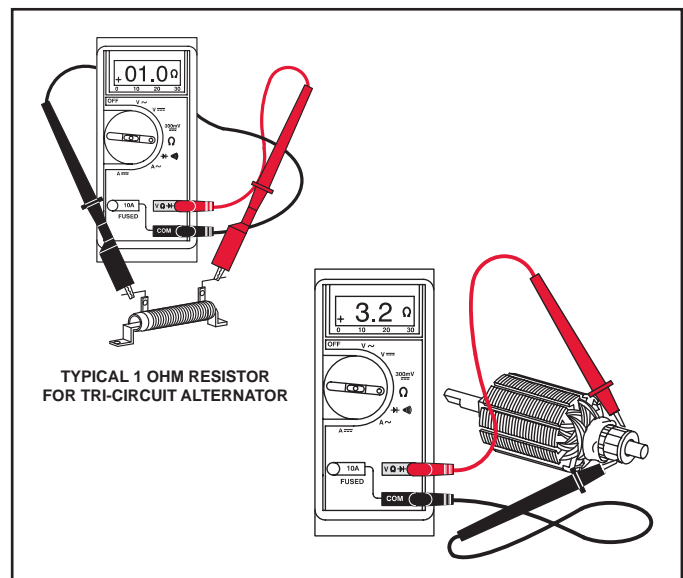

Resistance Checks

DIODE CHECKS

In the Diode Test position, the meter will display the forward voltage drop across the diode(s). If the voltage drop is less than 0.7 volt, the meter will “beep” once, as well as display the voltage drop. A continuous tone indicates continuity (shorted diode). An incomplete circuit (open diode) will be displayed as “OL”.

1. Insert RED test lead into $v \Omega \rightarrow$ receptacle in meter.
2. Insert BLACK test lead into **COM** receptacle in meter.
3. Rotate selector to  position.
4. Attach RED test lead to point “A” and BLACK test lead to point “B”. (It may be necessary to pierce wire with a pin as shown.)
 - a. If meter “beeps” once, diode is OK.
 - b. If meter makes a continuous tone, diode is defective (shorted).
 - c. If meter displays “OL”, proceed to step 5.
5. Reverse test leads.
 - a. If meter “beeps” once, diode is installed backwards.
 - b. If meter still displays “OL”, diode is defective (open).

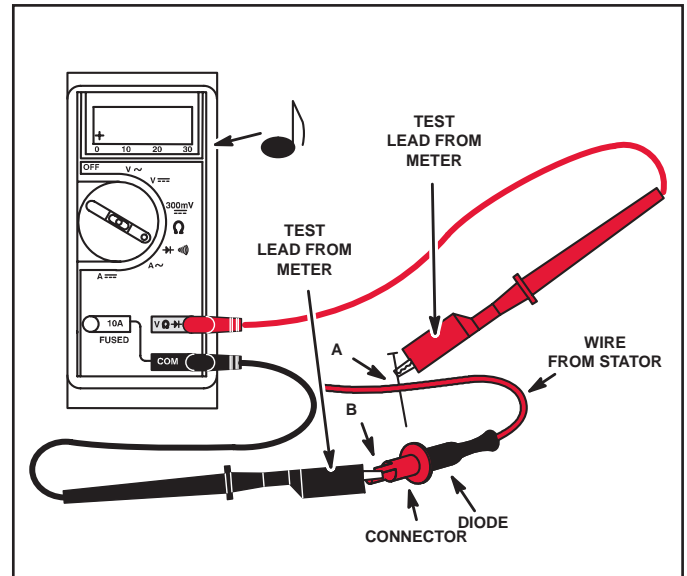

3 Amp DC

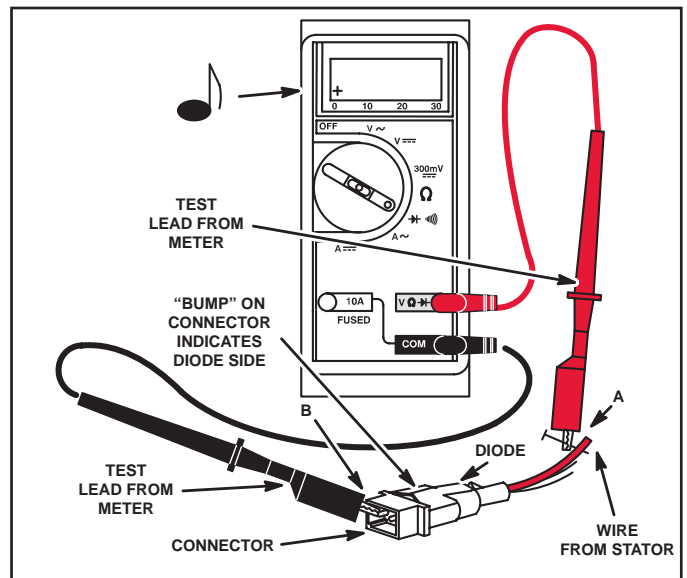

Dual Circuit – Charging Unit

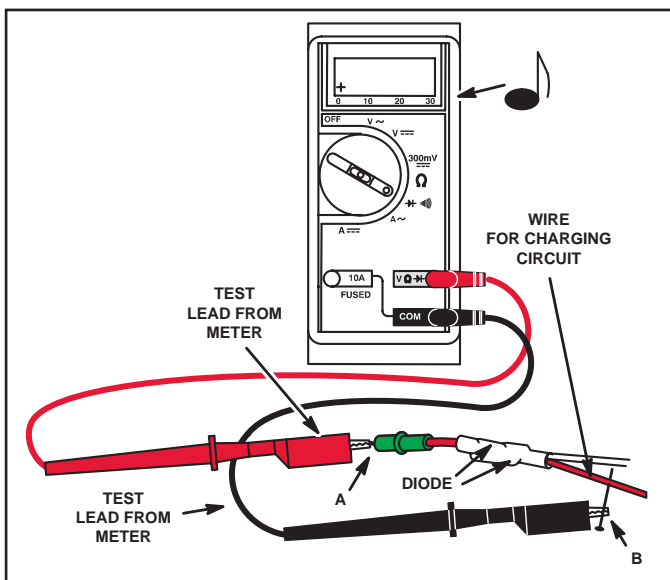

Tri-Circuit – Charging Circuit

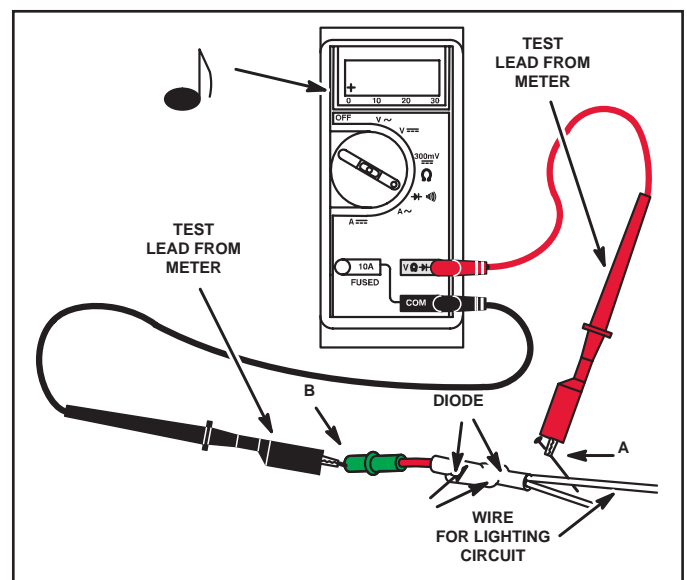

Tri-Circuit – Lighting Circuit

RED TEST LEAD	BLACK TEST LEAD	BEEP
B	A	Yes
C	B	Yes
C	D	Yes
D	A	Yes

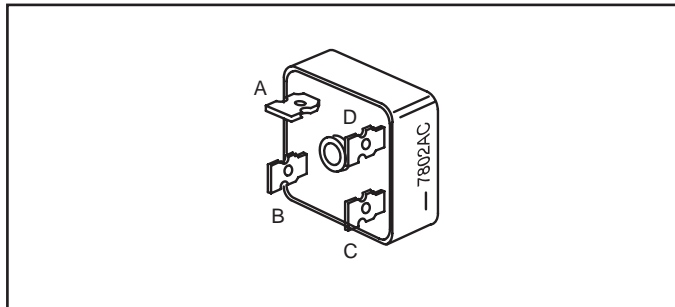

120 Volt Rectifier

NOTE: Metal cased rectifiers must also be tested for “grounds”, as follows:

With BLACK test lead probe contacting rectifier case, touch each terminal, A – D, with RED test lead probe. Meter should display “OL” at each terminal. If meter makes a continuous tone at any terminal, rectifier is defective (“grounded”).

DC SHUNT

Have you ever wanted one tool in your toolbox that would make your life so much easier that it would pay for itself after the first couple of uses? That tool might well be the **19359** DC shunt. The DC shunt is a device that enables the technician to make several electrical tests with only one hook-up to the equipment. By using the DC shunt, we can test for system draw with the key switch off, system draw with the key switch on, starter peak amp and steady amp draw, and alternator charging. All of these tests can be done in about 30 seconds taking all the guess work out of the process.

Electricity is one of those mysterious entities that most of us are at best, very leery of or at worst, down right frightened of. But once we have a basic understanding of electrical theory, and acknowledge that electricity has to follow strict physical properties, electrical testing becomes one of the easiest troubleshooting problems we will encounter.



HOW DOES A SHUNT WORK?

Several years ago we introduced the **19359** DC Shunt as a complement to the Fluke Digital Multi-meter. Though a very effective and useful tool, two questions usually come up:

Why is a reading taken in millivolts to read amperage?

Can I use the shunt with another brand of meter?

The shunt works by adding a measured load (resistance) to a DC series circuit. Any load in a circuit will cause a voltage drop across that particular part of the total load. The two meter connecting posts are across part of the total load. The load in this case is the resistance to the flow of electrons through the shunt body between the posts. The meter must be set to the millivolt scale in order to obtain the correct reading. This is actually a much safer approach than working with higher amperage.

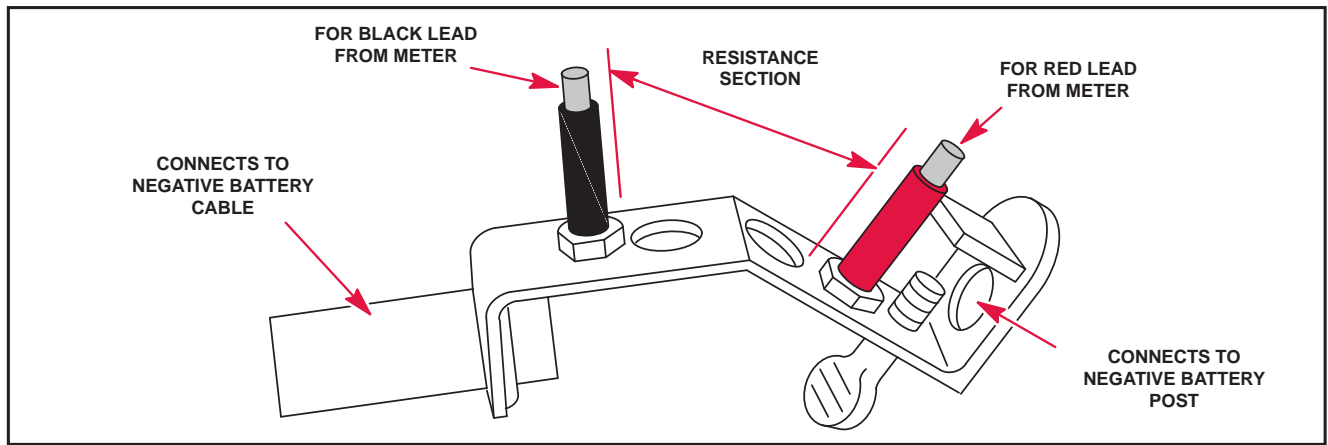

Previous Style

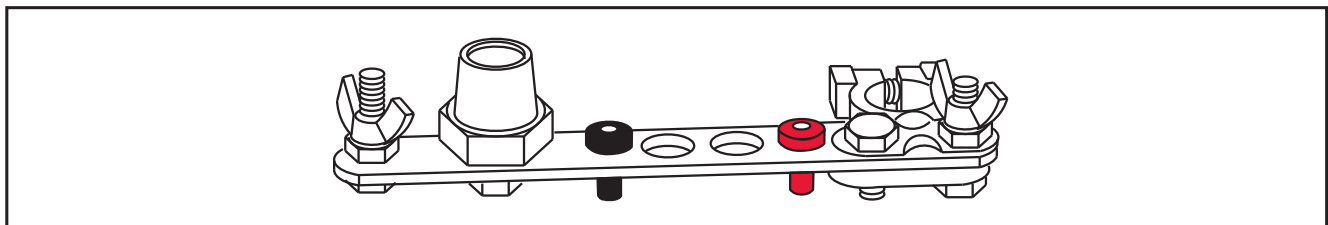

Current Style

Note: Meter and battery connections to shunt are the same as the previous DC shunt as shown above.

OHM'S LAW FORMULA

Some background information may help to make this clearer. Ohm's Law states that 1 volt of electrical pressure is required to move 1 amp of current (electron flow) through 1 ohm of resistance. Expressed mathematically, $E=IxR$ or volts equals amps multiplied by resistance.

$$1 \text{ volt} = 1 \text{ amp} \times 1 \text{ ohm}$$

The DC shunt is designed to have a predetermined resistance of 0.001 ohm between the meter connection posts. When we use the shunt to check the alternator charge rate, amps is the unknown. Changing Ohm's Law around to determine the current gives us:

$$1 \text{ amp} = \frac{1 \text{ volt}}{1 \text{ ohm}}$$

Let's take a look at units of measure. The prefix "milli" is Latin for 1/1000 of a unit. For example, 0.001 inch could be called a milliinch. Therefore, 1/1000 of an amp equals 0.001 amp or one milliamp. Also, one millivolt is 1/1000th of a volt or 0.001 volt. Applying these units of measurement for Briggs & Stratton shunt into Ohm's Law gives us:

$$1 \text{ amp} = \frac{1 \text{ millivolt}}{1 \text{ milliohm}} = \frac{0.001 \text{ volt}}{0.001 \text{ ohm}}$$

The above equation shows that across the posts on the Briggs & Stratton shunt, 1 milliohm equals 1 amp of current flowing in the circuit. This is why the test meter is set to the millivolt range.

Now, let's add charging current from the alternator system flowing through the shunt. Resistance through the shunt will stay the same. We know the current will change. Since the shunt measures voltage drop, we have to be interested in the voltage or pressure in the system. The resistance value of the shunt is set so that we know there is a 1 to 1 ratio between amps and millivolts. Therefore, a reading of 2 millivolts on the meter face is equal to 2 amps of current, 3 equals 3, etc.

From this discussion, it should be clear that any meter capable of reading millivolts can be used with the DC shunt.

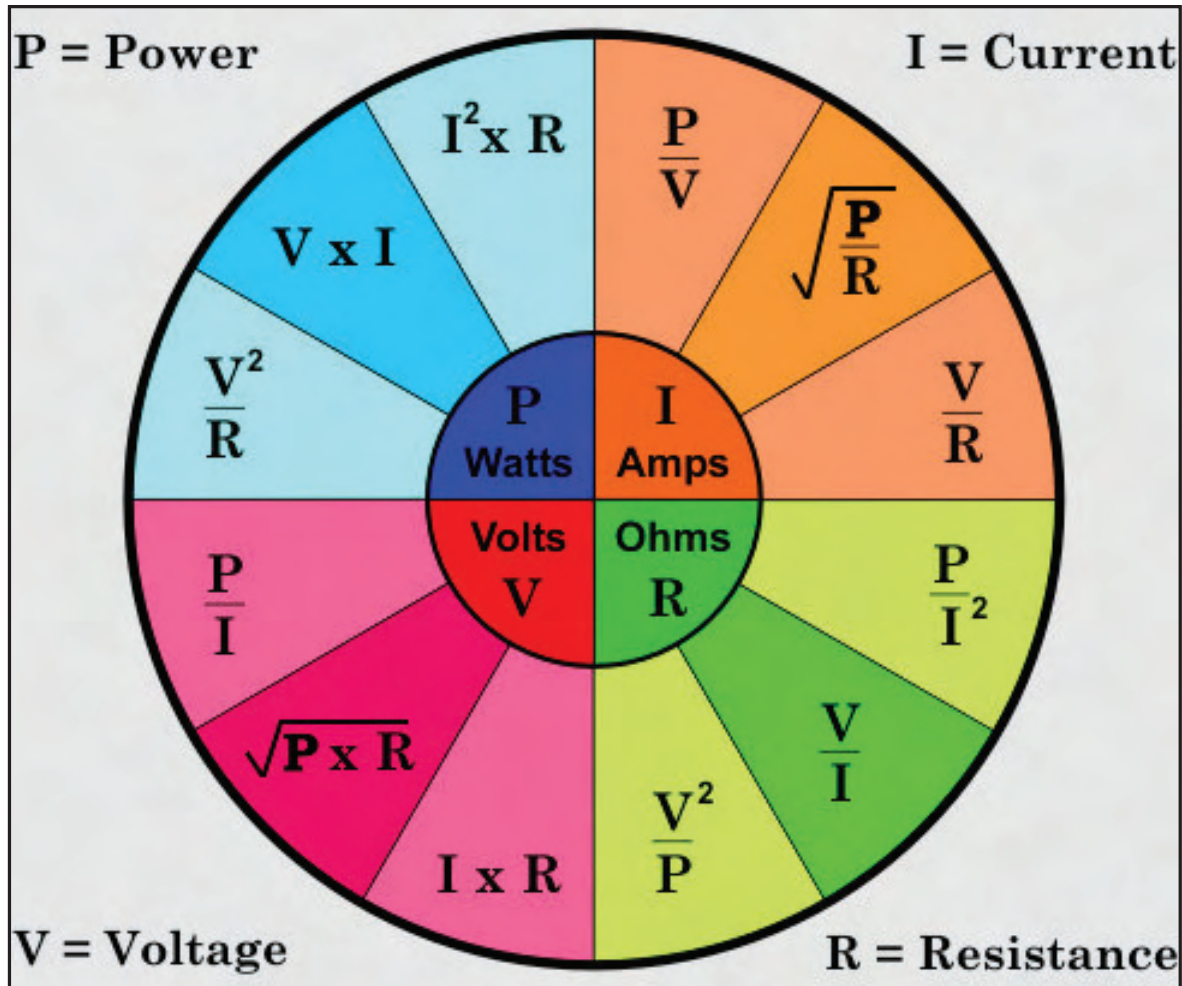

DC SHUNT INSTRUCTIONS

The DC shunt, part number **19468** readily adapts to standard mount, side mount or tab type battery terminals. The shunt must be installed on the - (negative) terminal of the battery.

For standard terminals, attach ring terminal on shunt to post terminal on battery. For tab terminal batteries, attach shunt to battery terminal using 1/4" – 20 stud and wing nut. For side terminal batteries, remove post terminal from shunt and thread into side terminal on battery. Attach battery cable to shunt using 3/8" – 16 nut from post terminal.

The Digital Multimeter will withstand DC input of 10 – 20 Amps for up to 30 seconds. To avoid blowing fuse in meter, use the DC shunt when checking current draw of 12 volt starter motors or DC output on 16 Amp regulated alternator.

Charging output can be checked with the engine running. All connections must be clean and tight for correct amperage readings.

1. Install shunt on negative battery terminal.

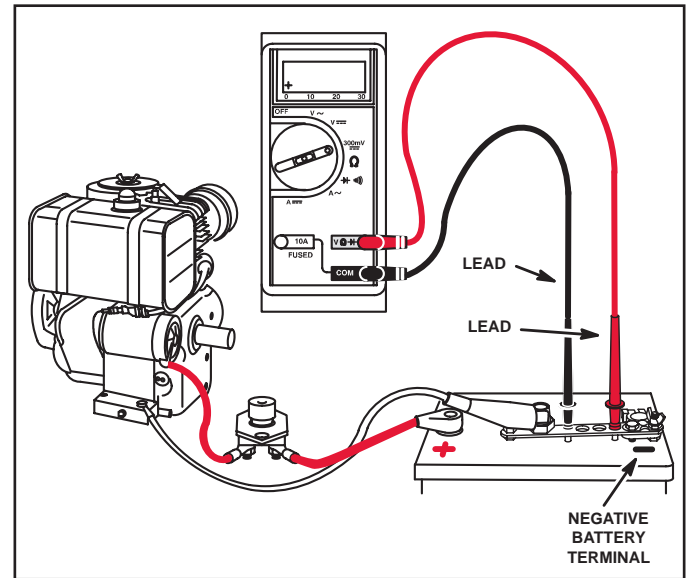

2. Insert RED test lead into $v \Omega \rightarrow$ receptacle in meter and RED receptacle on shunt.
3. Insert BLACK test lead into **COM** receptacle in meter and BLACK receptacle on shunt.
4. Rotate selector switch to 300mV --- position.

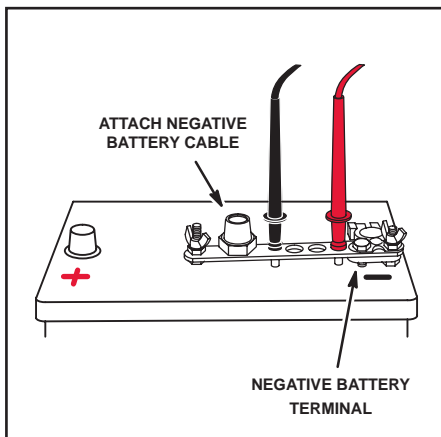

Standard Mount

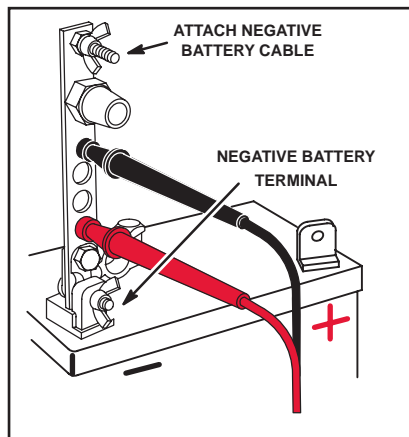

Tab Mount

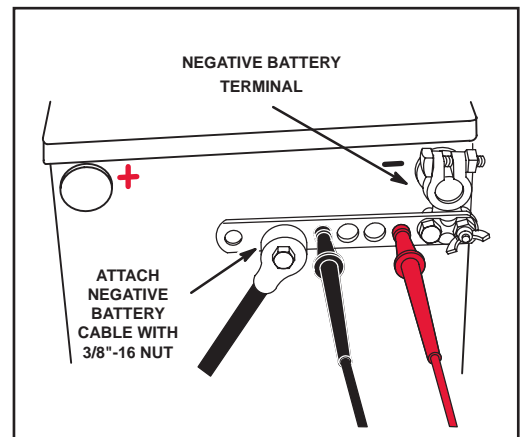

Side Mount

NO-LOAD STARTER CURRENT DRAW 12 VOLT STARTER MOTORS 300mV_{DC}

(STARTER MOTOR REMOVED FROM ENGINE)

To check the no-load amperage draw of a 12 volt starter motor that is removed from the engine, a fixture as shown in the figure should be used. See the diagram for the parts necessary to make a test set-up.



CAUTION: DO NOT clamp motor housing in a vise. Starter motors contain two ceramic magnets which can be broken or cracked if the motor housing is deformed or dented.

NOTE: When checking starter current draw, battery voltage must not be below 11.7 volts.

1. Install shunt on - (negative) battery terminal.
2. Insert RED test lead into Ω receptacle in meter and RED receptacle on shunt.
3. Insert BLACK test lead into **COM** receptacle in meter and BLACK receptacle on shunt.

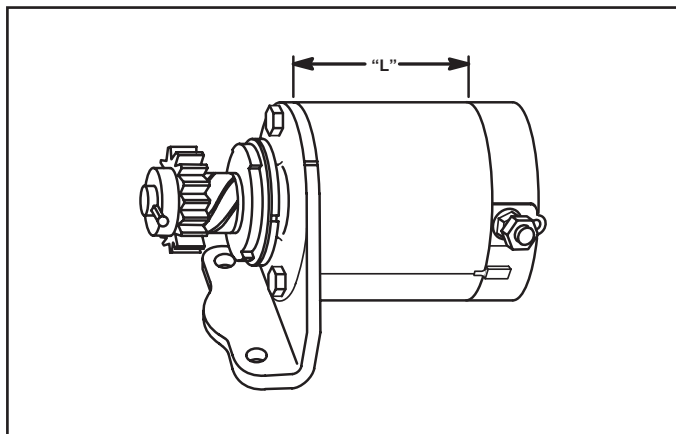

Starter Motor Housing Length

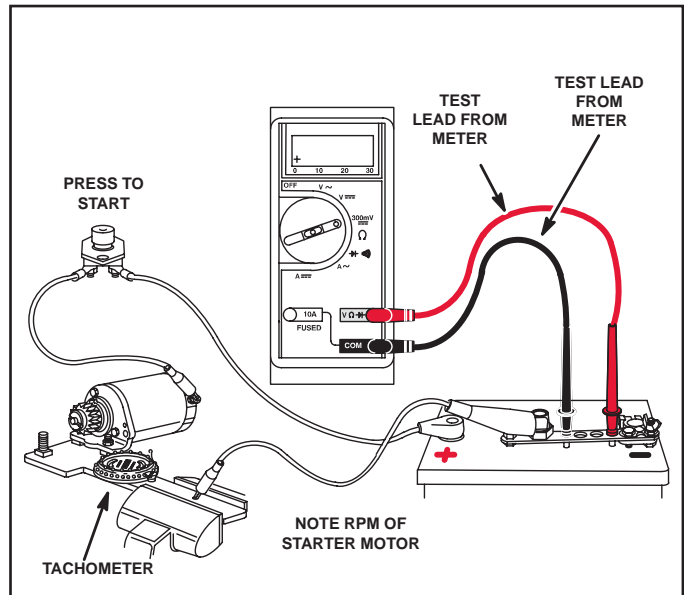

12 Volt Starter Current Draw – DC Shunt

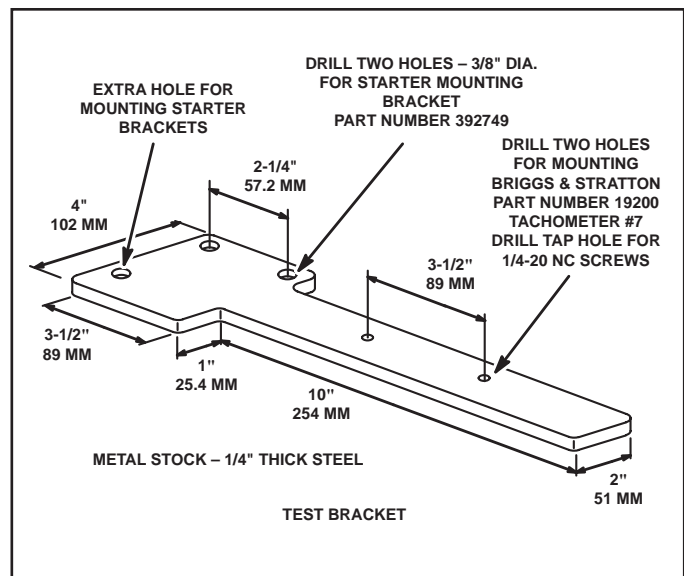

How to Make the Test Mounting Bracket

TABLE 1

12 VOLT STARTER MOTOR SPECIFICATIONS

MOTOR HOUSING LENGTH	MINIMUM RPM	MAXIMUM AMPERAGE
3" (76 mm)	6500	18
3-5/8" (92 mm)	6500	18
3-3/4" (95 mm)	6500	19
4-3/8" (111 mm)	6500	20
4-1/2" (114 mm)	6500	35

4. Rotate meter selector to 300mV_{DC} position.
5. Activate the starter switch:
 - a. Note RPM on vibration tachometer.
 - b. Note amperage on meter.
6. Note starter motor housing length and refer to

Table 1 for test specifications for starter motor being tested.

7. If the starter motor does not meet the specifications shown in the chart, refer to the Repair Instruction Manual, Section 7, for service and repair procedure.

STARTER CURRENT DRAW – 12 VOLT STARTER MOTORS **300mV**

(STARTER MOTOR MOUNTED ON ENGINE)

To check the amperage draw of a starter motor mounted on the engine, the procedure is similar to checking the starter motor off the engine. The battery cable and key switch harness installed in the equipment may be substituted for the test harness shown.

When making this current draw test, it is important to monitor the engine RPM, amperage draw and battery voltage. On all 12 volt starter systems, make sure the test is performed with the correct oil in engine, and belts removed from the PTO shaft. Remove the spark plug(s) and ground the spark plug wire(s) using Ignition Tester(s), Tool part number **19368**. Also the engine temperature should be at least 68 to 70° F (20° C).

NOTE: When checking starter current draw, battery voltage must not be below 11.7 volts.

1. Install shunt on - (negative) battery terminal.
2. Insert RED test lead into Ω receptacle in meter and RED receptacle on shunt.
3. Insert BLACK test lead into **COM** receptacle in meter and BLACK receptacle on shunt.
4. Rotate meter selector to position.
5. Activate the starter switch:
 - a. Note RPM on vibration tachometer.
 - b. Note amperage on meter.
6. If the amperage draw exceeds 100 amps and the engine RPM is less than 350, it could indicate a starter motor problem. Check the starting system, such as the battery, cables, solenoid and connections. Then proceed to check the starter motor by performing the no-load starter motor test as indicated on page 8 or refer to the Briggs & Stratton Repair Instruction Manual, Section 7.

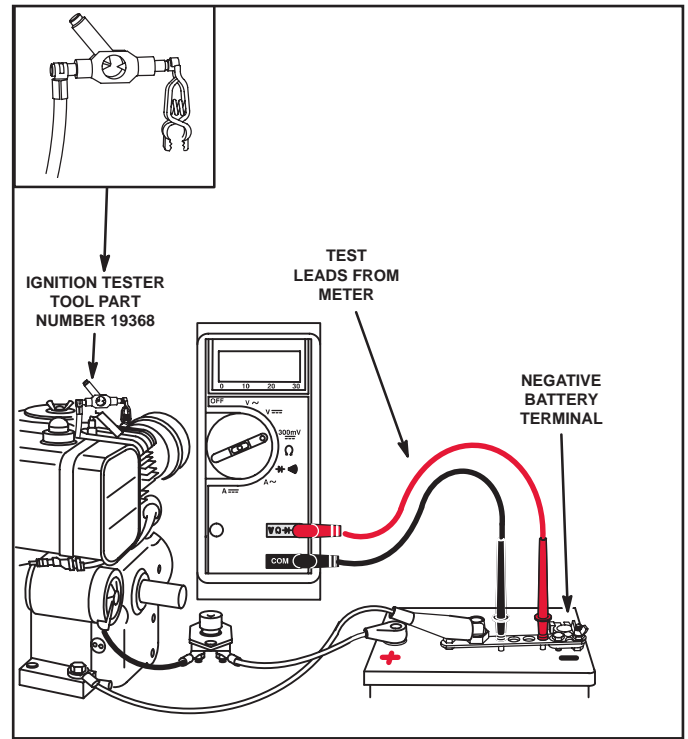

12 Volt Starter Current Draw – DC Shunt

AC VOLTAGE OUTPUT CHECK $v \sim$

1. Insert RED test lead into $v \sim$ receptacle in meter.
2. Insert BLACK test lead into **COM** receptacle in meter.
3. Rotate selector to position.
4. Attach RED test clip to alternator AC output terminal(s).
5. Attach BLACK test clip to engine ground.

NOTE: When checking AC voltage output of stator on 10-16 and 20 amp regulated or Quad-Circuit alternator systems, attach one meter test clip to each output pin terminal in YELLOW connector from stator. Test clip leads may be attached to either output pin.

6. With engine running at 3600 RPM, AC output reading should be close to specification listed for alternator type in Table 2.

ALTERNATOR	AC OUTPUT AT 3600 RPM
AC ONLY	14 VOLTS
DUAL CIRCUIT	14 VOLTS
• 5 AMP REGULATED	28 VOLTS
• 9 AMP REGULATED	40 VOLTS
TRI-CIRCUIT	28 VOLTS
QUAD-CIRCUIT	30 VOLTS
• 10 AMP REGULATED	20 VOLTS
• 16 AMP REGULATED	30 VOLTS
• 16 AMP REGULATED	26 VOLTS

• Alternator output is determined by flywheel alternator magnet size.

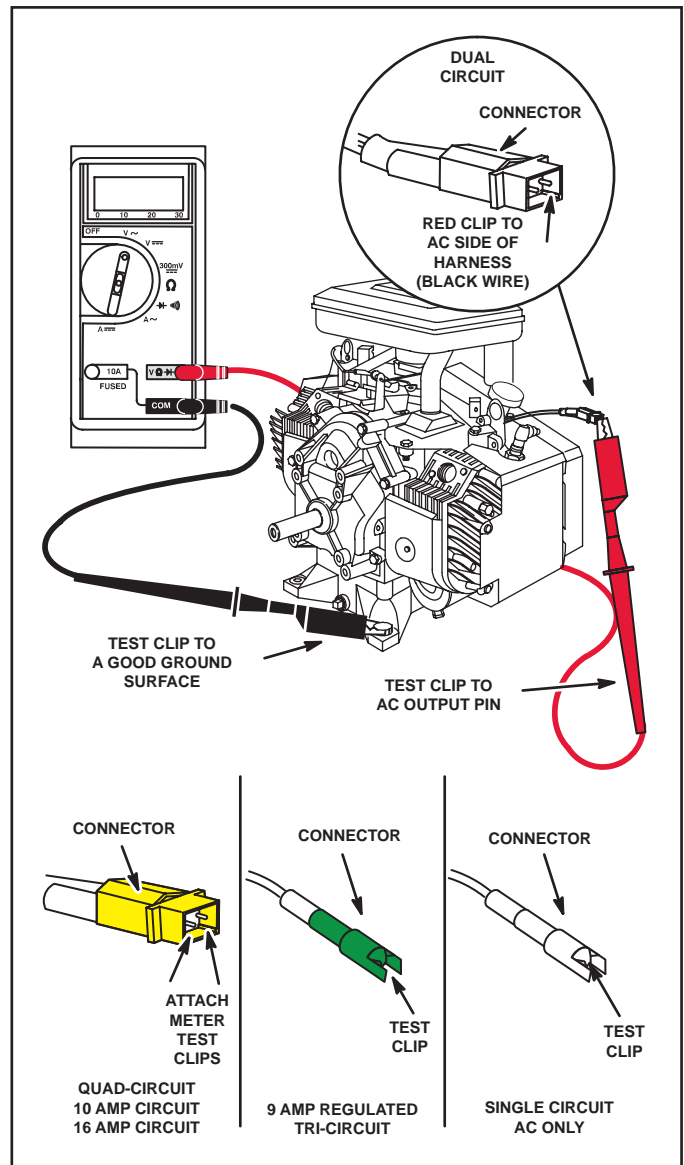

AC Voltage Output Check

DC AMPERAGE OUTPUT CHECK **A**---

See Note Below For 1/2 Amp and System 3 & 4 Alternators

See Page 14 for Special Instructions on Checking DC Amperage Output of 16 and 20 Amp Regulated System

1. Insert RED test lead into **10A** receptacle in meter.
2. Insert BLACK test lead into **COM** receptacle in meter.
3. Rotate selector to **A**--- position.
4. Attach RED test clip to DC output terminal.
5. Attach BLACK test clip to + (positive) battery terminal. (See note for System 3 & 4 alternators.)
6. With engine running at 3600 RPM, DC output reading should be close to specifications listed for alternator type shown in Table 3.

NOTE: 1/2 AMP AND SYSTEM 3 & 4 DC AMPERAGE OUTPUT CHECK:

Follow DC output check procedure as described above through step 4.

At step 5, attach BLACK test clip to ground.

At step 6, with engine running at 2800 RPM, DC output should be no less than 0.5 amp.

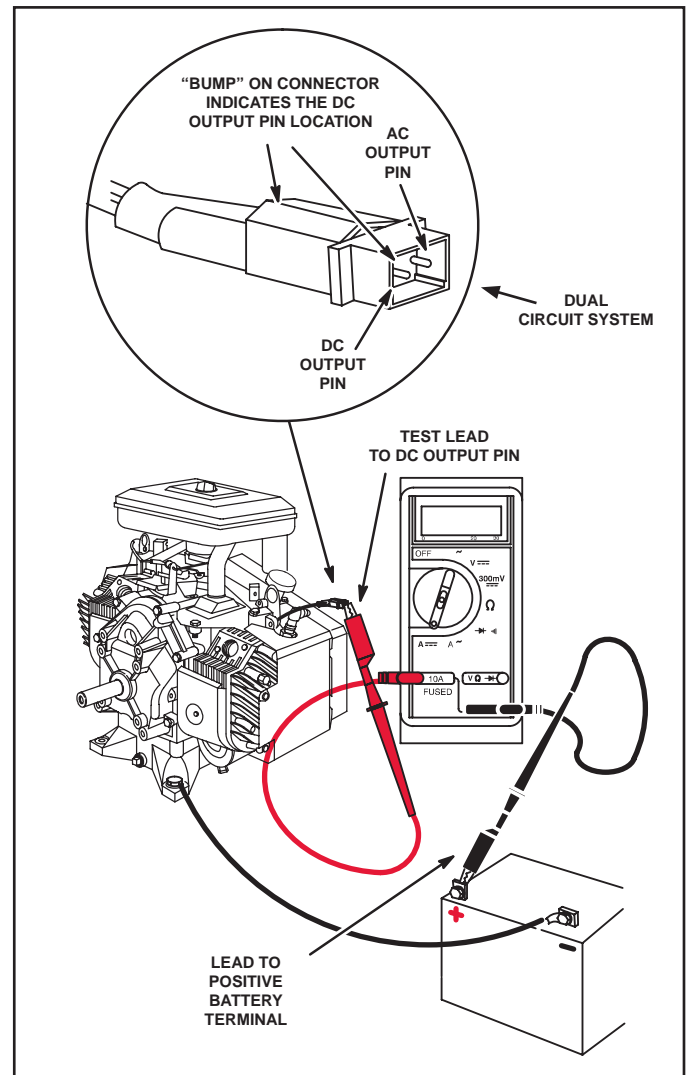

DC Amperage Output Check

TABLE 3	
ALTERNATOR TYPE	DC OUTPUT
1/2 AMP, SYSTEM 3 & 4	.5 AMP
DC ONLY (VANGUARD™) (1.2 AMP)	1.2 AMP
DC ONLY (MODEL 130000) (1.5 AMP)	1.5 AMP
DC ONLY (3 AMPS)	**2-4 AMPS
DUAL CIRCUIT	**2-4 AMPS
*QUAD-CIRCUIT	**3-8 AMPS
*5 AMPS REGULATED	**3-5 AMPS
*9 AMPS REGULATED	**3-9 AMPS
*10 AMPS REGULATED	**3-10 AMPS
*16 AMPS REGULATED	**3-16 AMPS
*20 AMPS REGULATED	**3-20 AMPS

* Connect test leads before starting engine. Be sure connections are secure. If a test lead vibrates loose while engine is running, the regulator/rectifier may be damaged.

** Amperage will vary with battery voltage. If battery voltage is at its maximum, the amperage will be less than the higher value shown.

CHECKING DC AMPERAGE OUTPUT

16 & 20 AMP REGULATED ALTERNATOR

To avoid blowing fuse in meter when testing DC output of 16 and 20 amp system the DC Shunt, Tool part number **19468**, is required.

The DC Shunt must be installed on the - (negative) terminal of the battery. All connections must be clean and tight for correct amperage readings.

1. Install shunt on negative battery terminal.
2. Insert RED test lead into $v \Omega \rightarrow$ receptacle in meter and RED receptacle on shunt.
3. Insert BLACK test lead into **COM** receptacle in meter and BLACK receptacle on shunt.
4. Rotate selector to $300mV\text{---}$ position.
5. With engine running at 3600 RPM, DC output reading should be close to specifications listed in Table 3.

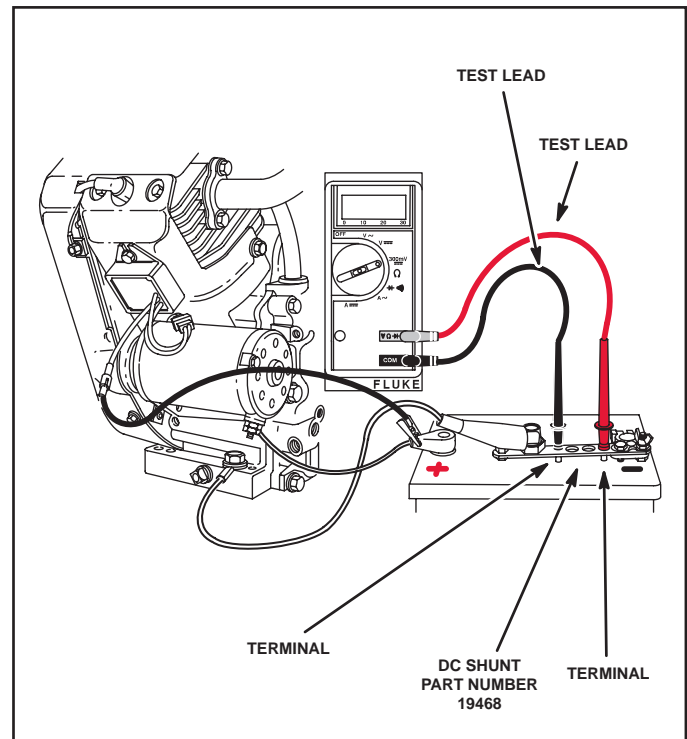

**DC Amperage Output Check
16 and 20 Amp System – DC Shunt**

STARTER MOTOR CURRENT DRAW 120 VOLT STARTER MOTORS A ~

Use Line Current Adapter, Tool part number **19358**, when checking current draw on 120 volt starter motors. Use the same test fixture used in the 12 volt starter test to check the current draw and free running RPM of motor.

! The following test procedure must be used to avoid any accidental shock hazard to the service technician.

1. Insert BLACK test lead from adapter, Tool part number **19358**, into the **COM** receptacle in meter.
2. Insert white test lead from adapter, Tool part number **19358**, into the **10A** receptacle in meter.
3. Plug the adapter cord (female end) into the switch box receptacle of the starter motor.
4. Plug the adapter cord (male end) into the previously tested wall outlet.
5. Rotate selector to A ~ position.
6. Refer to specifications, Table 4, and note maximum allowable amperage draw for motor being tested.
7. Depress starter switch button. When meter reading stabilizes, (approximately 3 seconds) amperage should not exceed the specification shown in Table 4.



CAUTION: If amperage is higher than specification in Table 4, immediately stop the test! An amperage reading higher than number in chart, indicates a shorted starter motor, which could be dangerous.

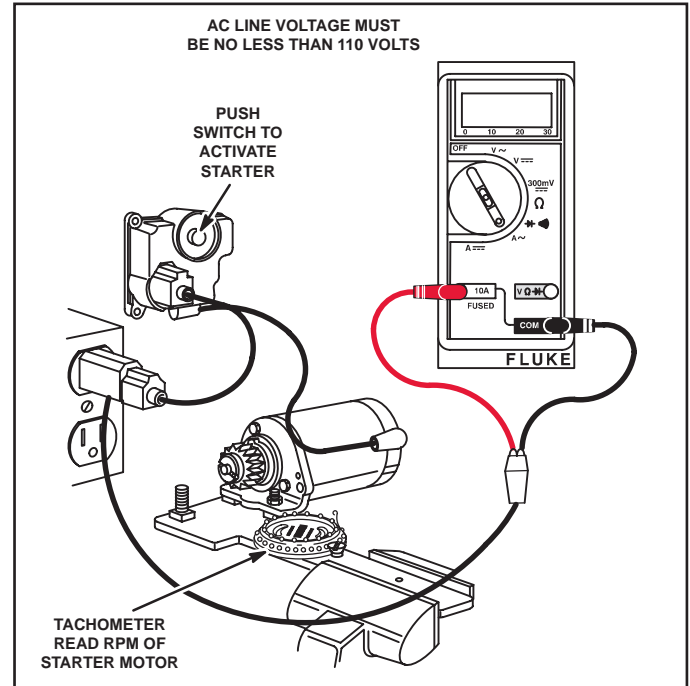

**120 Volt AC Starter Motor Current Draw
with Line Current Adapter**

TABLE 4		
120 VOLT STARTER MOTOR SPECIFICATIONS		
STARTER MOTOR IDENTIFICATION	MAXIMUM AMPERAGE	MINIMUM RPM
American Bosch SME-110-C3 SME-110-C6 SME-110-C8	3.5	7400
American Bosch 06026-28-M030SM	3.0	7400
Mitsubishi J282188	3.5	7800
Briggs & Stratton 3-1/2" (75.45 mm) Motor Housing	2.7	6500

8. If starter motor amperage is within specification, check RPM using vibration tachometer, Tool part number **19200**.
9. RPM should be close to specifications listed in Table 4.
10. If the starter motor does not meet the given specifications, refer to the Repair Instructions Manual, Section 7.

ELECTRIC STARTER KITS QUICK REFERENCE

ENGINE MODEL	STARTER ASSEMBLY#		STARTER GEAR ONLY#		DRIVE ASSY. # (BENDIX)	
Single Cylinder Engines						
190400-196499	497595	(Plastic Ring Gear)	695708	(Plastic Ring Gear)	696541	(C Ring Type)
190700-195799	693054	(Alum. Ring Gear)	693059	(Alum. Ring Gear)	696540	(Roll Pin Type)
252700-252799	693551	(Steel Ring Gear)	693713	(Steel Ring Gear)	693699	(Steel Ring Gear)
253700-253799	499521	(Plastic Ring Gear/Starter Housing is Over 4" in Length)				
194700-198799	499521	(Alum. Ring Gear/Starter Housing is Over 4" in Length)				
195400-195799	693552	(Steel Ring Gear/Starter Housing is Over 4" in Length)				
19E400-19E499						
19F400-19F499						
19G400-19G499						
19K400-19K499						
280700-289799						
28A700-28W799						
Single Cylinder Intek™ Engines						
120100-15D100	793667	120 volt (60Hz Starter Assembly)				
	699786	230 volt (50Hz Starter Assembly)				
20A100-21P200	795909	120 volt (60HZ Starter Assembly)				
	792157	230 volt (50Hz Starter Assembly)				
310700-310799	497595	(Plastic Ring Gear)	695708	(Plastic Ring Gear)	696541	(C Ring Type)
311700-311799	497595	(Alum. Ring Gear)	693059	(Alum. Ring Gear)		
312700-312799	693551	(Steel Ring Gear)	693699	(Steel Ring Gear)	693713	(Steel Ring Gear)
Opposed Twin Cylinder Engines						
400400-422499	497596	(3 5/8" Housing)	695708		696541	(C Ring Type)
400700-422799	498148	(4 3/8" Housing)			696540	(Roll Pin Type)
42A700-42E799					496181	(Steel Pinion Gear)
406700-461799						
V-Twin Vanguard™ Engines						
303400-303499	499521		695708		696541	(C Ring Type)
354400-354499	691564	(Steel Pinion Gear)	N/A	(Steel Pinion Gear)	496881	(Steel Pinion Gear)
350700-350799						
380400-381499						
380700-381799						
303700-303799	499521		695708		696541	(C Ring Type)
304400-304499	691564	(Steel Pinion Gear)	N/A	(Steel Pinion Gear)	496881	(Steel Pinion Gear)
350400-350499						
351400-351499						
351700-351799						
381400-381499	691564	(Steel Pinion Gear)	695708		696541	(C Ring Type)
381700-381799						
V-Twin Intek™ Engines						
405700-405799	499521		695708		696541	
406700-406799						
407700-407799						
445700-445799						

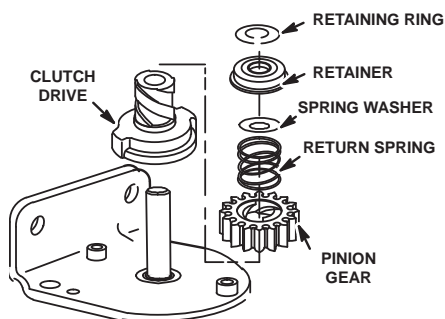

C-Ring Type

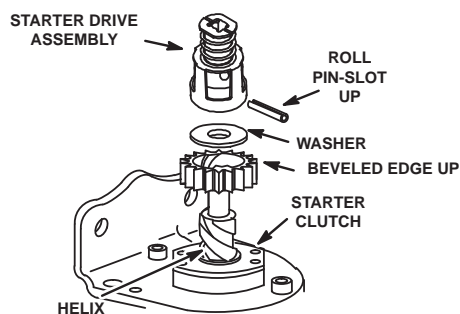

Roll Pin Type

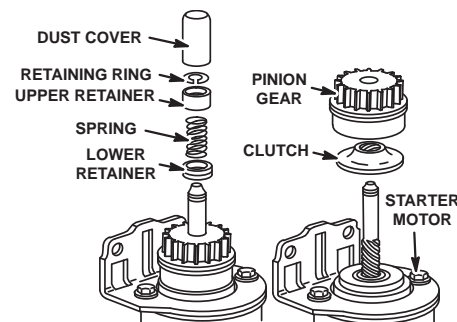

Steel Ring Gear

ALTERNATOR IDENTIFICATION

Briggs & Stratton engines are equipped with a number of different alternator systems to meet the requirements of equipment manufacturers. For example, a large lawn tractor with accessories may require a 16 amp regulated system, whereas a snow thrower with a single headlight requires an AC Only system. Knowing the type of alternator system an

engine is equipped with is important, particularly when an engine is being replaced.

Briggs & Stratton alternator systems are easily identified by the color of the stator output wire(s) and the connector.

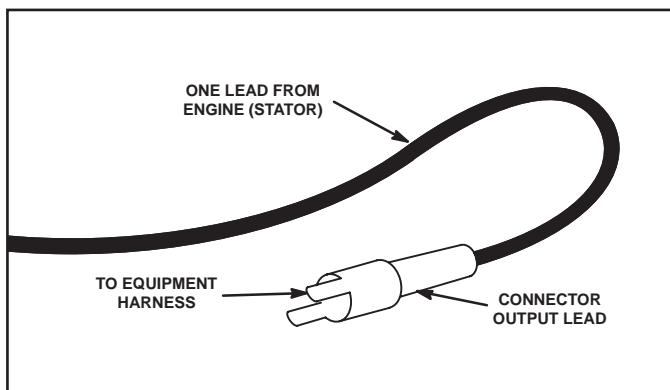
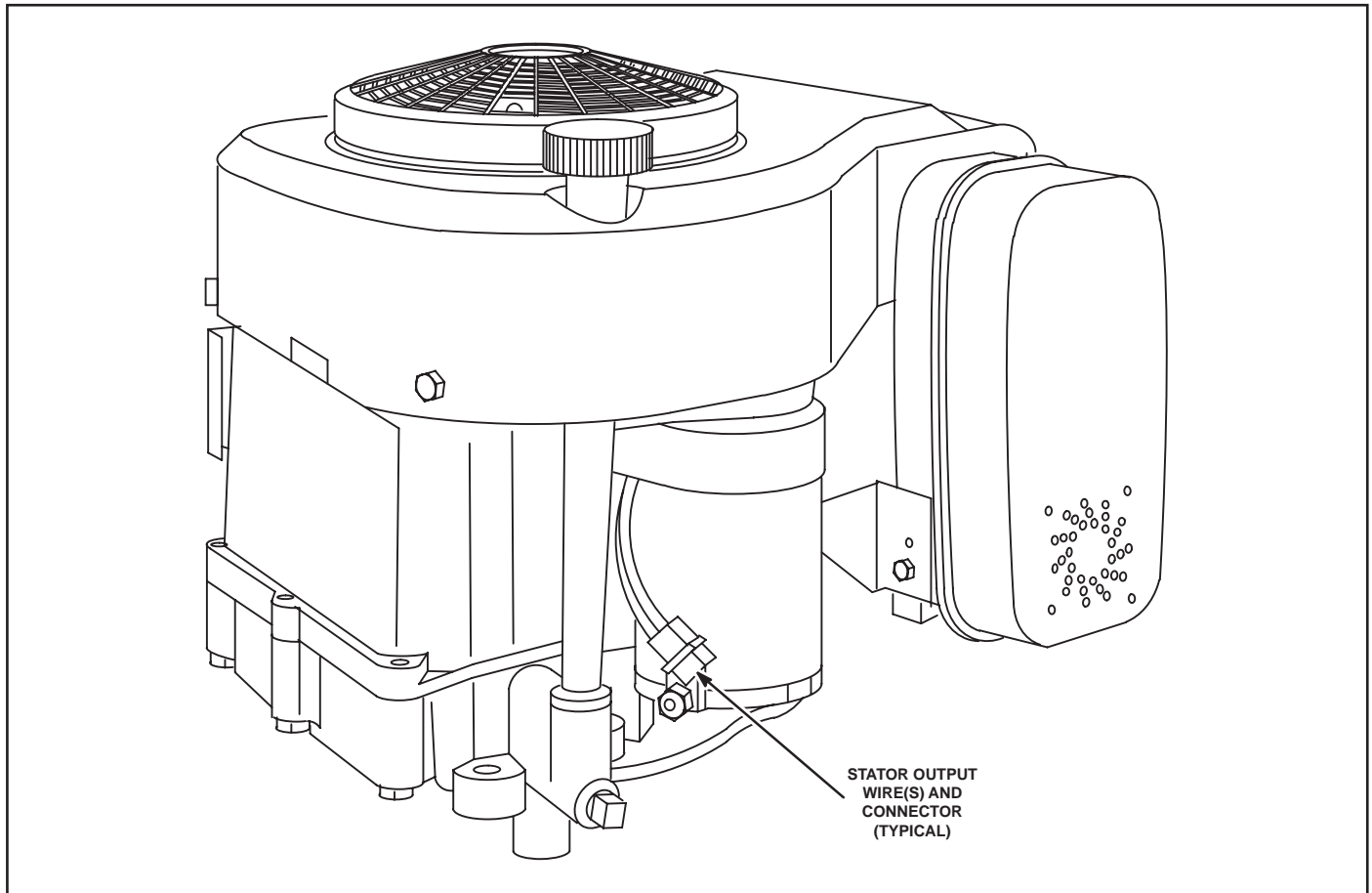

AC Only

- 14 Volts AC for lighting circuit.
- One BLACK lead from stator.
- White connector output lead.

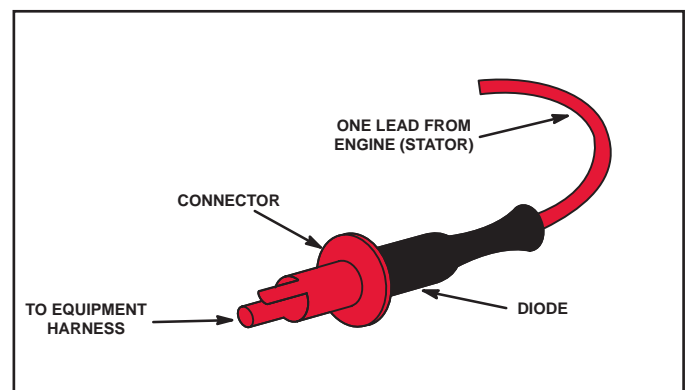

DC Only

- 3 amp DC unregulated for charging battery.
- One RED lead from stator.
- Diode encased at connector.
- RED connector output lead.

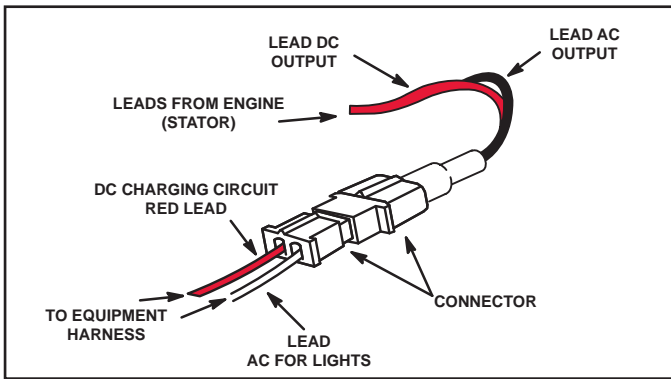

AC Only

- 3 amp DC unregulated for charging battery (ONE RED lead from stator).
- 14 Volts AC for lighting circuit (ONE BLACK lead from stator).
- Diode encased at connector.
- White connector with two pin terminals.

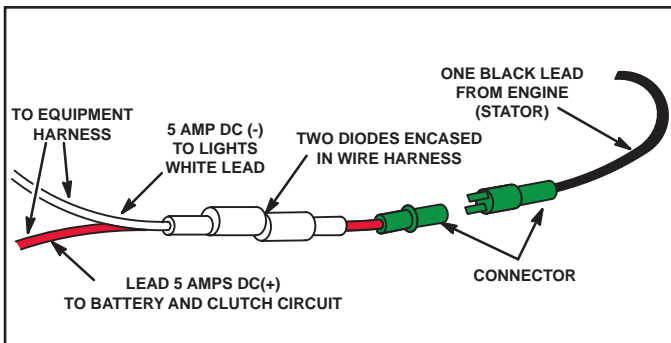

Tri-Circuit

- 10 amp AC.
- One BLACK lead from stator.
- GREEN connector.
- Two diodes encased in wire harness.
- RED and white output leads.

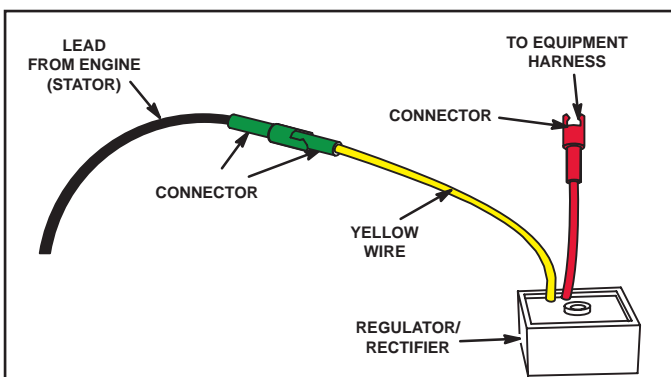

5 or 9 Amp Regulated

- 5 or 9 amp DC regulated for charging battery.
- Alternator output (5 or 9 amp) is determined by flywheel alternator magnet size.
- Uses same stator as Tri-Circuit system.
- One BLACK lead from stator.
- GREEN connector.

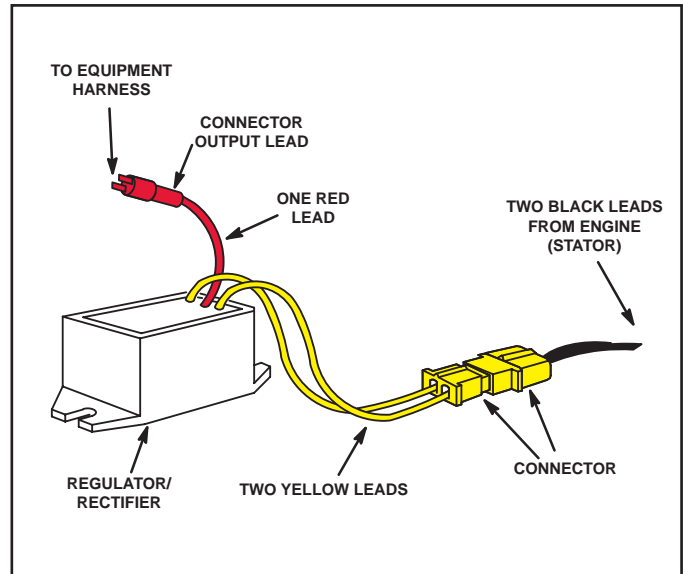

10 OR 16 Amp Regulated

- 10 or 16 amp DC regulated for charging battery.
- Alternator output is determined by the flywheel alternator magnet size.
- 10 and 16 amp system use the same stator, color coding and regulator/rectifier.
- Two BLACK leads from stator.
- YELLOW connector with two pin terminals.
- Two YELLOW leads to regulator/rectifier.
- One RED lead from regulator/rectifier to RED connector output lead.

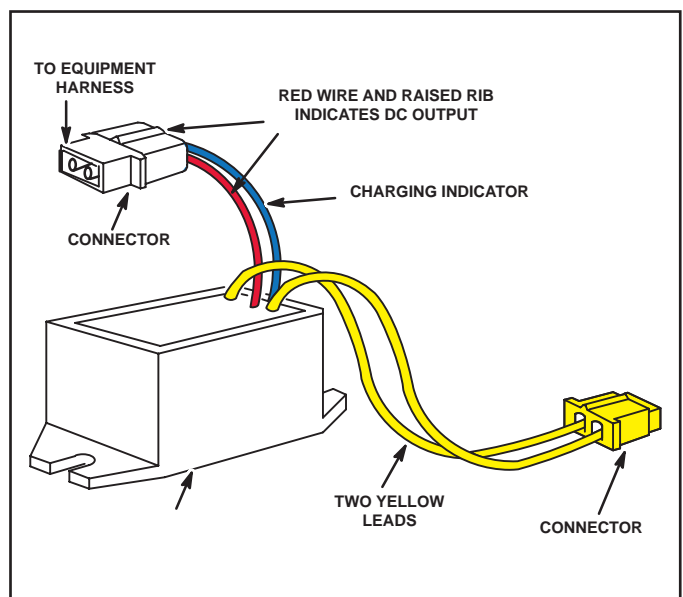

493219 Regulator/Rectifier Used With Charge Indicator Circuit

- Uses same stator as 10 and 16 amp system.
- DC output the same as 10 or 16 amp system.
- Charge indicator light and wiring supplied by equipment manufacturer.
- RED DC output wire to white connector.
- BLUE charge indicator wire to white connector.

ENGINE/ALTERNATOR REPLACEMENT INFORMATION

With the exception of the AC Only alternator, all of the alternator systems referred to in this book have a battery as part of the electrical system.

There are specialized applications that use an alternator without a battery. An example would be certain generators or welders that use alternator output to excite an electrical field. For the equipment to function, the alternator output must be very evenly matched to the equipment requirements. When replacing an engine in these applications, the alternator must be the same as the original.

REPLACING BRIGGS & STRATTON ENGINES

When replacing an older Briggs & Stratton engine on a piece of equipment with a newer Briggs & Stratton engine, sometimes the newer engine has an alternator system different from the alternator system on the original engine. This means that the output connector on the replacement engine is not compatible with the original wiring harness on the piece of equipment. For example, the original engine may have been equipped with a Dual Circuit system and the replacement engine is equipped with a

regulated system. We can integrate the two systems by making an adapter harness from readily available parts.

Generally an unregulated DC system (DC Only, Dual Circuit) should not be used to replace a regulated system because alternator output may not be sufficient for equipment requirements. However, because the equipment requirements are usually much less on an unregulated DC system, a regulated system may be used as a replacement. The regulator/rectifier prevents the battery from being over charged.

NOTE: The AC Only, DC Only, Dual Circuit, Tri-Circuit as well as the 5 and 10 amp regulated systems use flywheels with small alternator magnets. The 9 and 16 amp regulated systems use flywheels with the large alternator magnets. See figure below for magnet sizes.

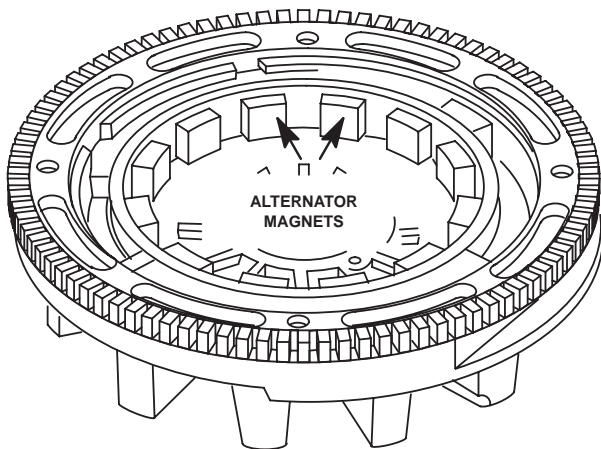

*Small Magnet	7/8" x 11/16" (22mm x 18mm)
*Large Magnet	1-1/16" x 15/16" (27mm x 24mm)

*V Twin Alternator Magnet Size: Small 7/8" x 21/32" (22 mm x 17 mm)
Large 7/8" x 29/32" (22 mm x 23 mm)

The following are alternator replacement combinations which require an adapter harness.
All of the necessary components are shown.

1. Original engine equipped with AC Only alternator.
Replacement engine equipped with Dual Circuit alternator.

Modify **398661** harness supplied with replacement engine by removing RED DC wire. Then, splice **393537** connector into white AC wire and connect to equipment harness.

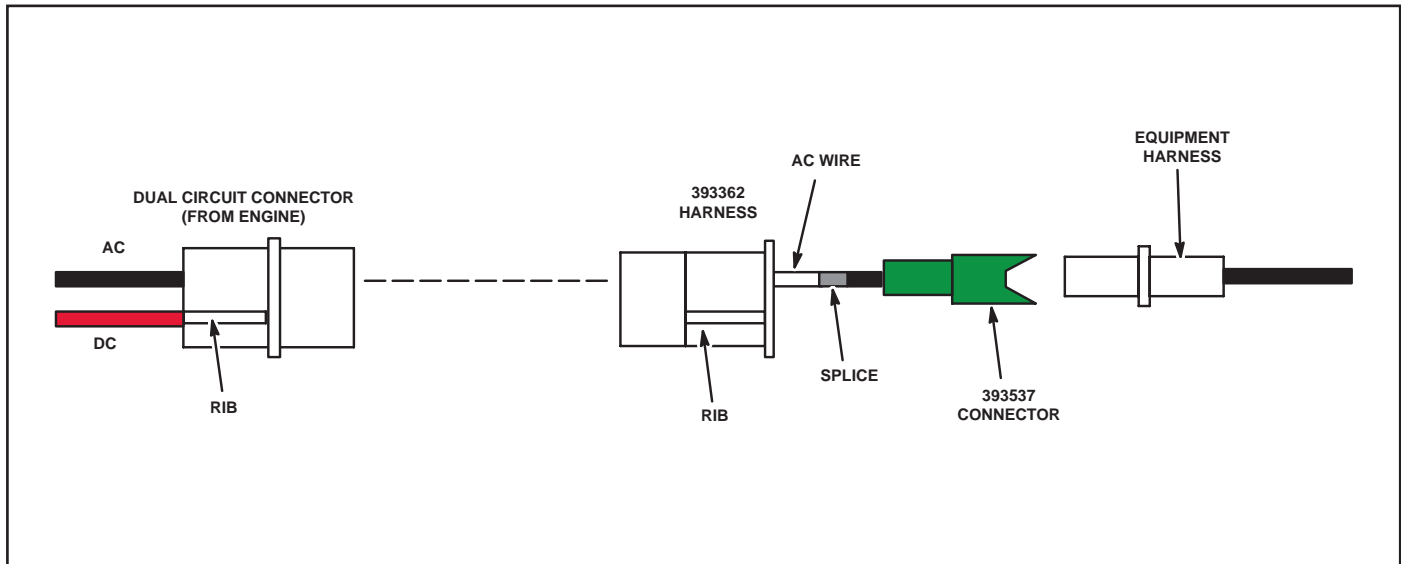

2. Original engine equipped with DC Only alternator.
Replacement engine equipped with Dual Circuit alternator.

Modify **398661** harness supplied with replacement engine by removing white AC wire. Then, splice **393537** connector into RED DC wire and connect to equipment harness.

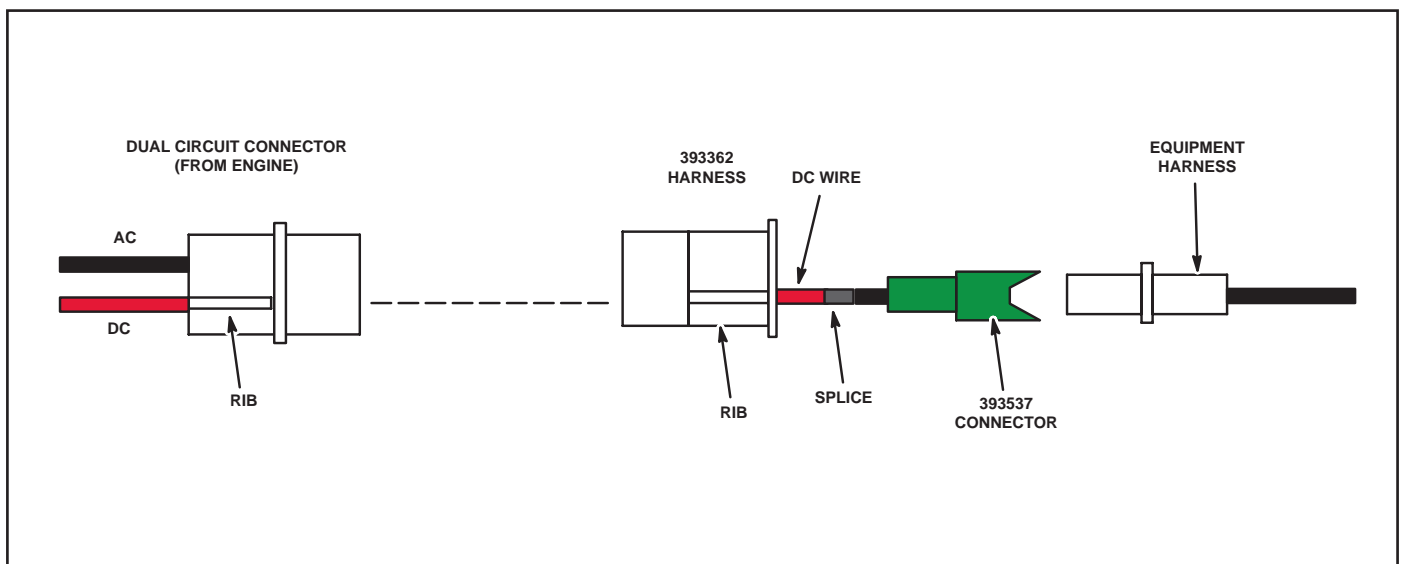

3. Original engine equipped with Dual Circuit alternator.
 Replacement engine equipped with 5, 9, 10 or 16 amp regulated system.

Modify **692306** harness supplied with replacement engine by splicing in **399916** connector assembly. Connect to equipment harness.

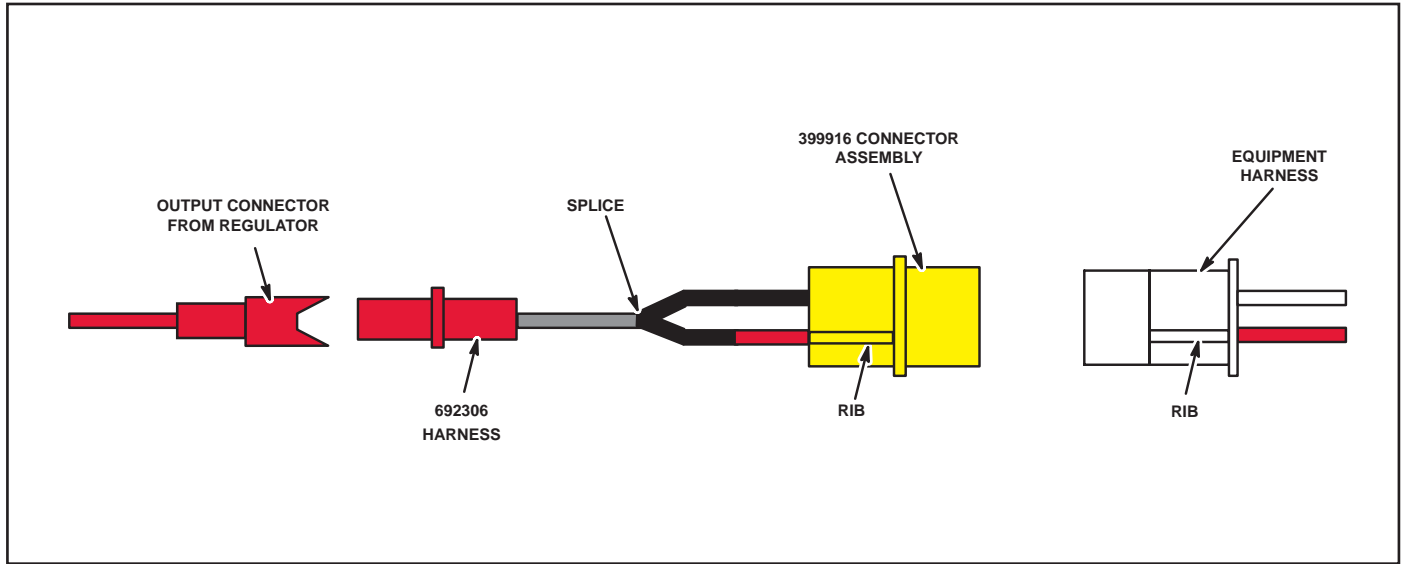

4. Original engine equipped with Tri-Circuit alternator.
 Replacement engine equipped with 5, 9, 10 or 16 amp regulated system.

Modify **692306** harness supplied with replacement engine by splicing into charging circuit wire and lighting circuit wire in equipment harness.

NOTE: THE DIODES MUST BE REMOVED FROM THE EQUIPMENT HARNESS.

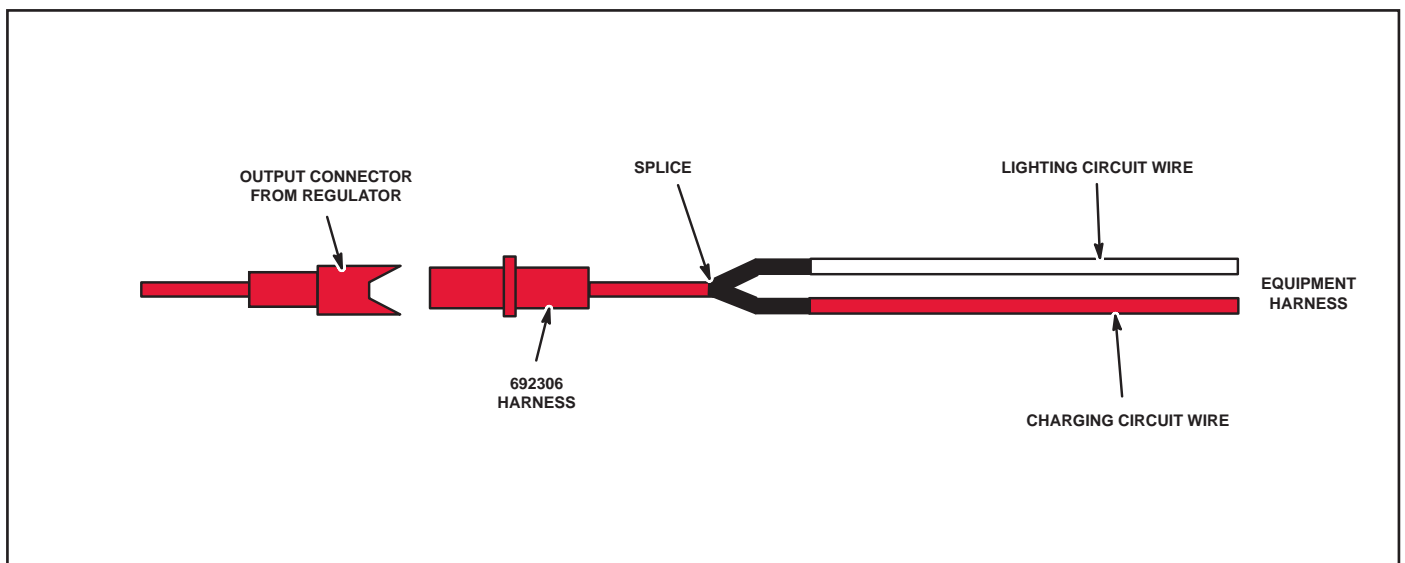

Diodes Must Be Removed From Equipment Harness

- Original engine equipped with Dual Circuit alternator.
Replacement engine equipped Tri-Circuit alternator.

Discard **691955** diode harness supplied with new engine. Install **794360** regulator/rectifier. Add **692306** harness and modify by splicing in **399916** connector assembly. Connect to equipment harness.

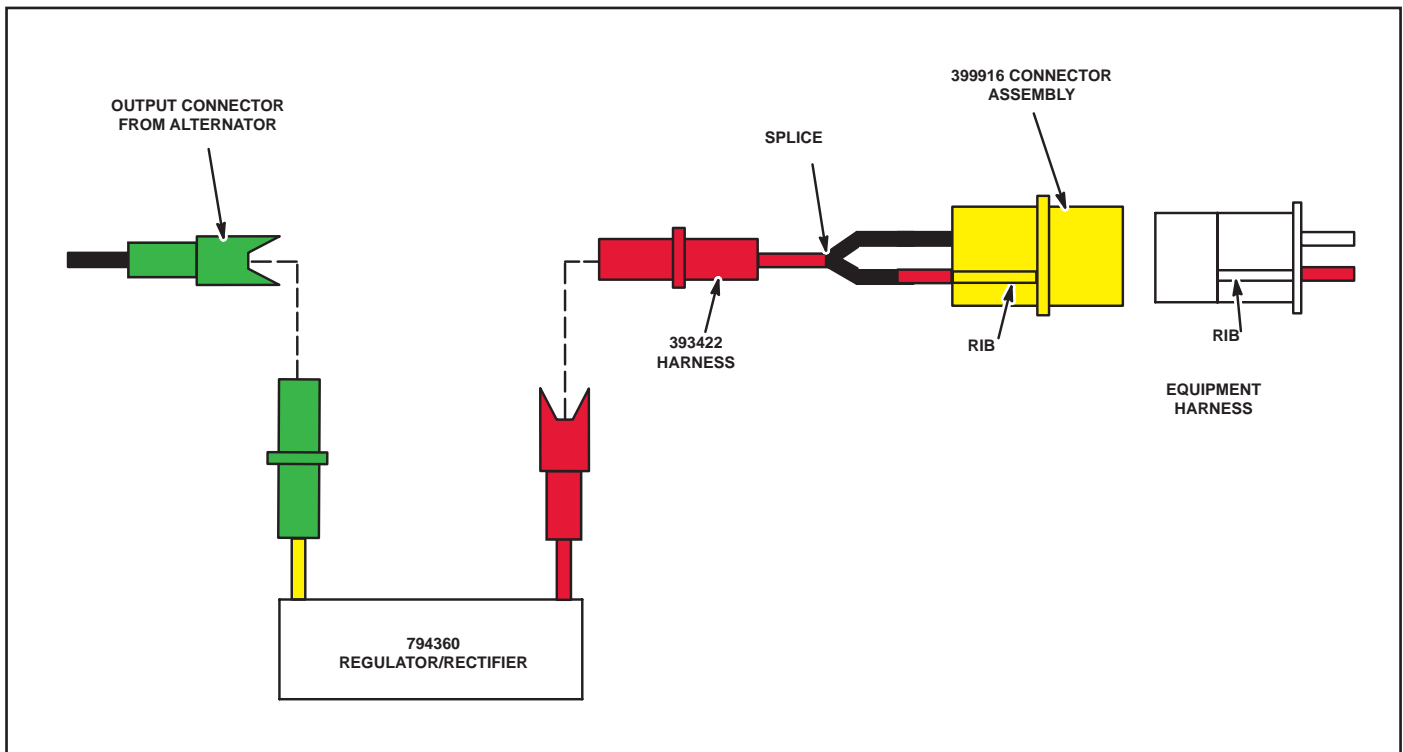

- Original engine equipped with 5 amp regulated system.
Replacement engine equipped with Tri-Circuit alternator.

Discard **691955** diode harness supplied with new engine. Transfer **491546** regulator/rectifier from original engine. Connect to equipment harness.

The following alternator replacement combinations require no modifications.

- Original engine equipped with DC Only alternator.
Replacement engine equipped with 5, 9, 10 or 16 amp regulated system.
Direct Replacement. Connect to equipment harness.
- Original engine equipped with 5 amp regulated system.
Replacement engine equipped with 9, 10 or 16 amp regulated system.
Direct Replacement. Connect to equipment harness.
- Original engine equipped with 9 amp regulated system.
Replacement engine equipped with 10 or 16 amp regulated system.
Direct Replacement. Connect to equipment harness.
- Original engine equipped with 10 amp regulated system.
Replacement engine equipped with 9 or 16 amp regulated system.
Direct Replacement. Connect to equipment harness.

BRIGGS & STRATTON ENGINE REPLACING ENGINE OF ANOTHER MANUFACTURER

When replacing the engine of another manufacturer with a Briggs & Stratton engine, the equipment requirements must be known so that the replacement alternator system has the same output as the original system provided.

Often the equipment wiring harness is not compatible with the Briggs & Stratton alternator output harness. To create a compatible system it may be necessary to modify the equipment wiring harness. To do this, a wiring diagram for the equipment is essential.

The original keyswitch may also create a problem. Even though the keyswitch harness connectors appear to be identical, there are internal differences to keyswitches. Therefore it is necessary to have a diagram of the keyswitch showing the terminal positions and their functions. For example, see the 5 terminal switch diagrams in Figure 1 and Figure 2. The keyswitch in Figure 1 is compatible with all Briggs & Stratton alternators. Note in Figure 2, that when the "brand X" keyswitch is in the START position there is no battery voltage available to the #2 switch terminal. Consequently, if the replacement Briggs & Stratton engine was equipped with a carburetor solenoid, it would not function. This is why it is important to have a diagram of the keyswitch when replacing engines, or replace the keyswitch with one that is compatible with all Briggs & Stratton alternator systems.

NOTE: The 5 terminal Briggs & Stratton keyswitch, part number **490066**, shown in Fig. 1 has been replaced by a 6 terminal keyswitch, part number **692318**. The additional terminal provides a direct connection for the charging lead at the keyswitch.

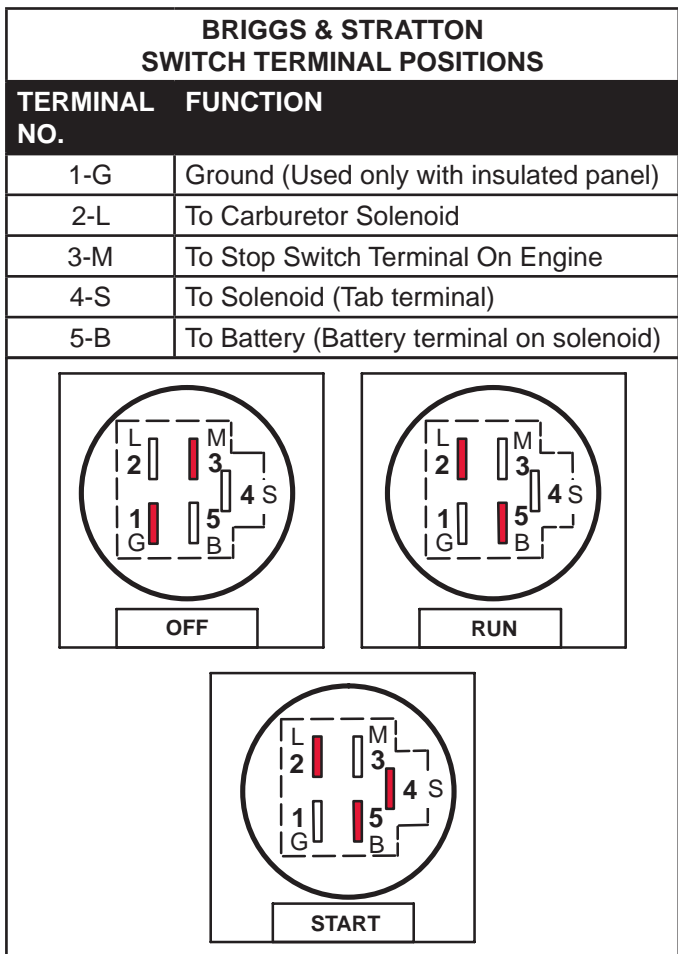

Figure 1

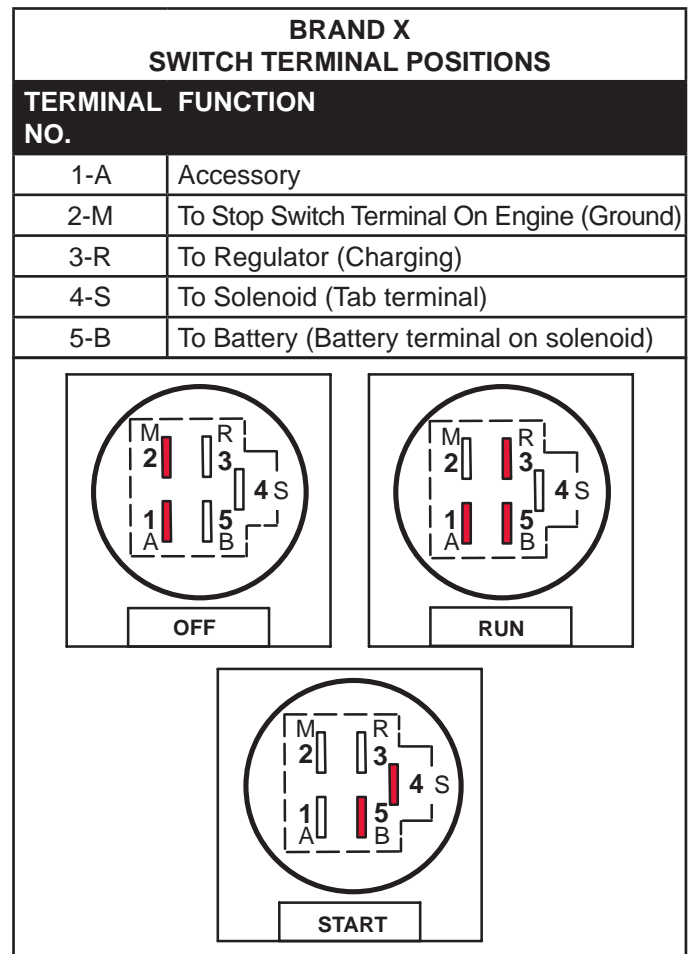
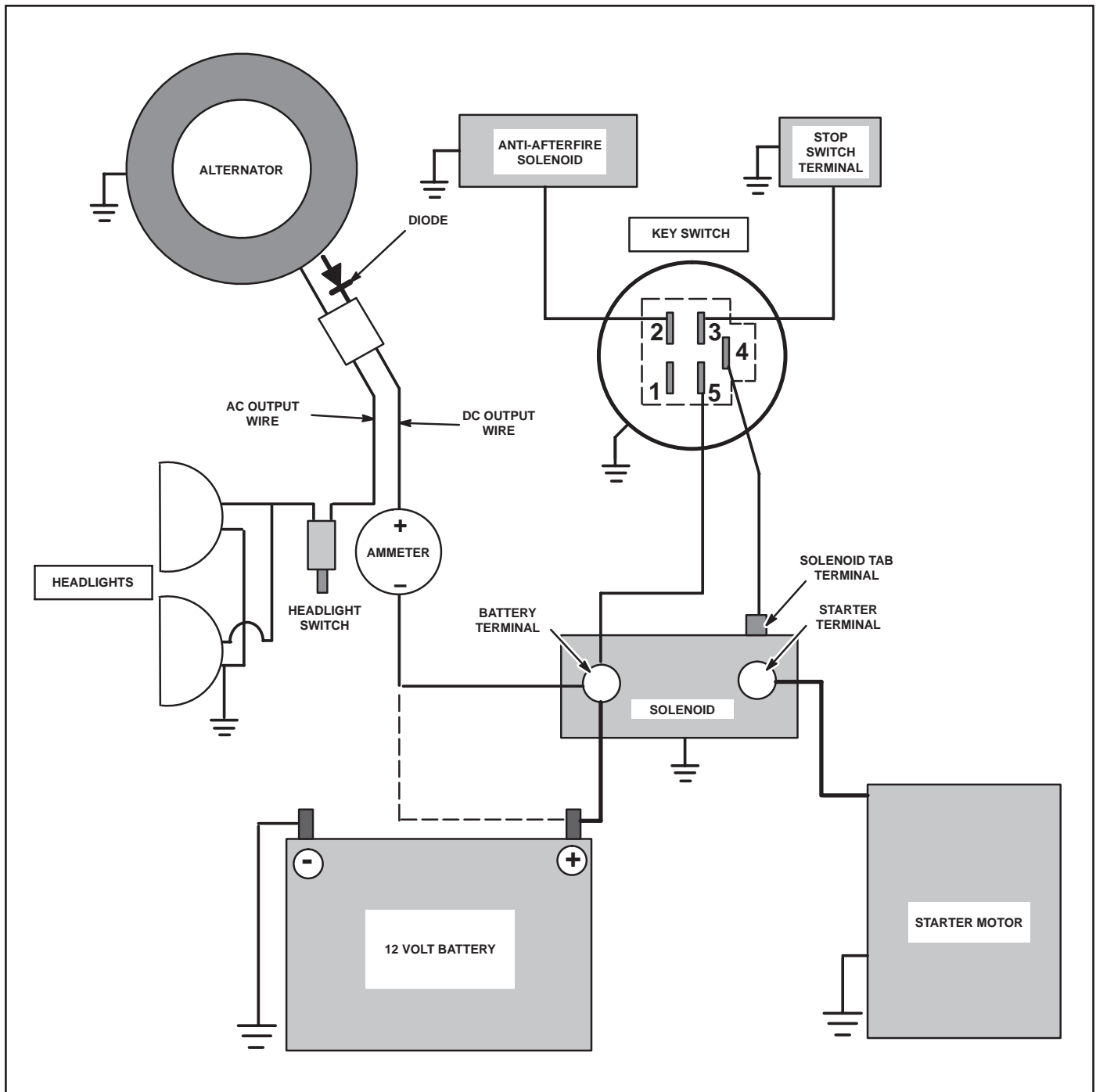

Figure 2

It is not possible to show all of the wiring diagrams or keyswitch combinations that are used by equipment manufacturers. However, the following wiring diagrams for the most popular Briggs & Stratton engines may be used as a guide when replacing an engine. The wiring diagrams show the type of keyswitch that is compatible with the alternator system shown.



Typical Dual Circuit Alternator
Wiring Diagram

Original 5 Pole Switch Superseded to 6 Pole Switch, Briggs & Stratton Part Number 692318

KEY SWITCH TEST	
SWITCH POSITION	CONTINUITY
1. OFF	*1 + 3
2. RUN	2 + 5
3. START	2 + 4 + 5

*Terminal 1 Grounded Internally
To Key Switch Case

TERMINAL NO.	FUNCTION
1	Ground (Used only with insulated panel)
2	To Carburetor Solenoid
3	To Stop Switch Terminal On Engine
4	To Solenoid (Tab terminal)
5	To Battery (Battery terminal on solenoid)

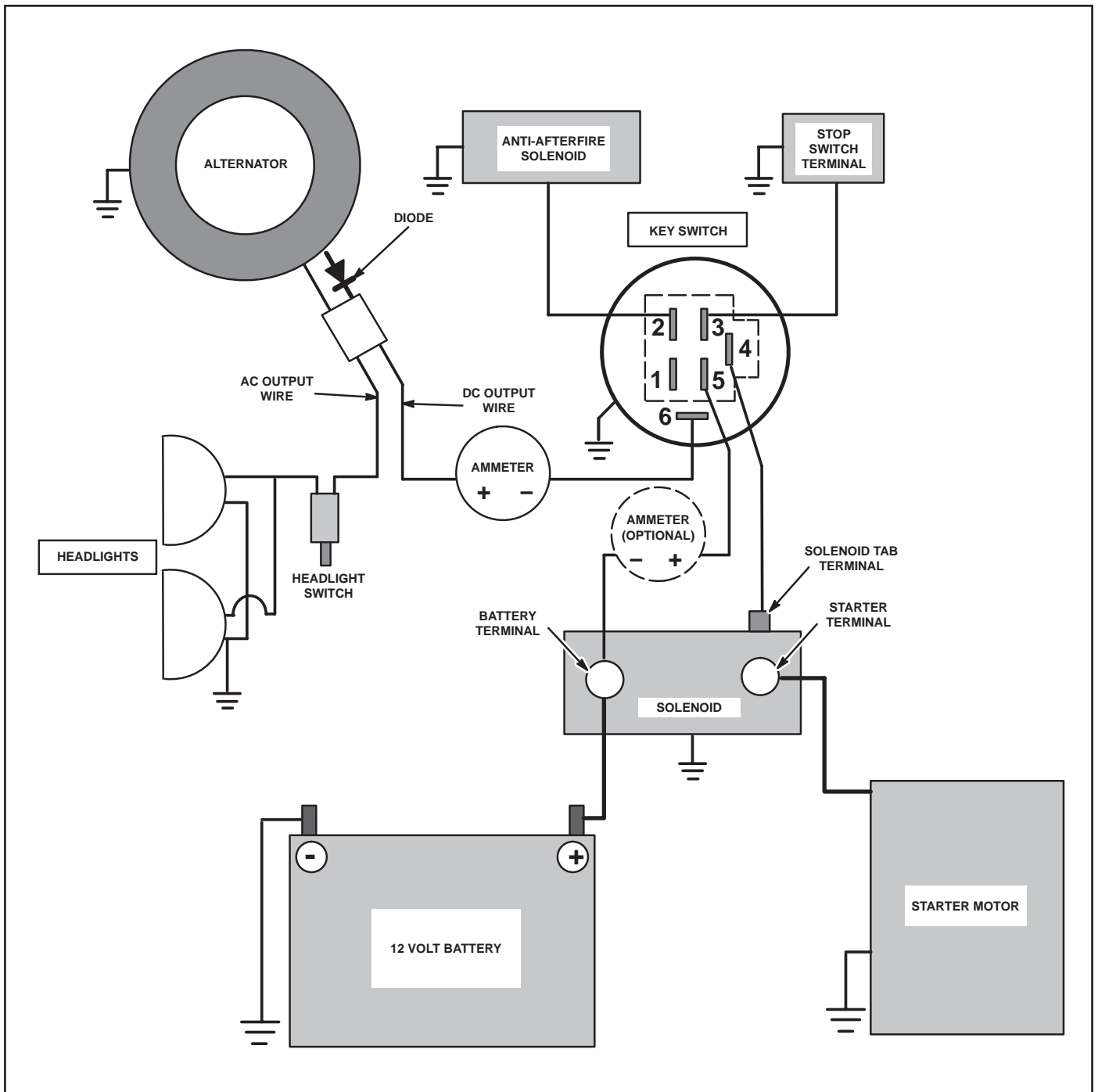

**Typical Dual Circuit Alternator
Wiring Diagram
6 Pole Switch – Briggs & Stratton Part Number 692318**

With ammeter shown in optional position, note that - and + symbols are reversed. The + symbol must always be connected to the alternator side.

KEY SWITCH TEST	
SWITCH POSITION	CONTINUITY
1. OFF	*1 + 3 + 6
2. RUN	2 + 5 + 6
3. START	2 + 4 + 5

*Terminal 1 Grounded Internally
To Key Switch Case

TERMINAL NO.	FUNCTION
1	Ground (Used only with insulated panel)
2	To Carburetor Solenoid
3	To Stop Switch Terminal On Engine
4	To Solenoid (Tab terminal)
5	To Battery (Battery terminal on solenoid)
6	To Alternator (DC Output)

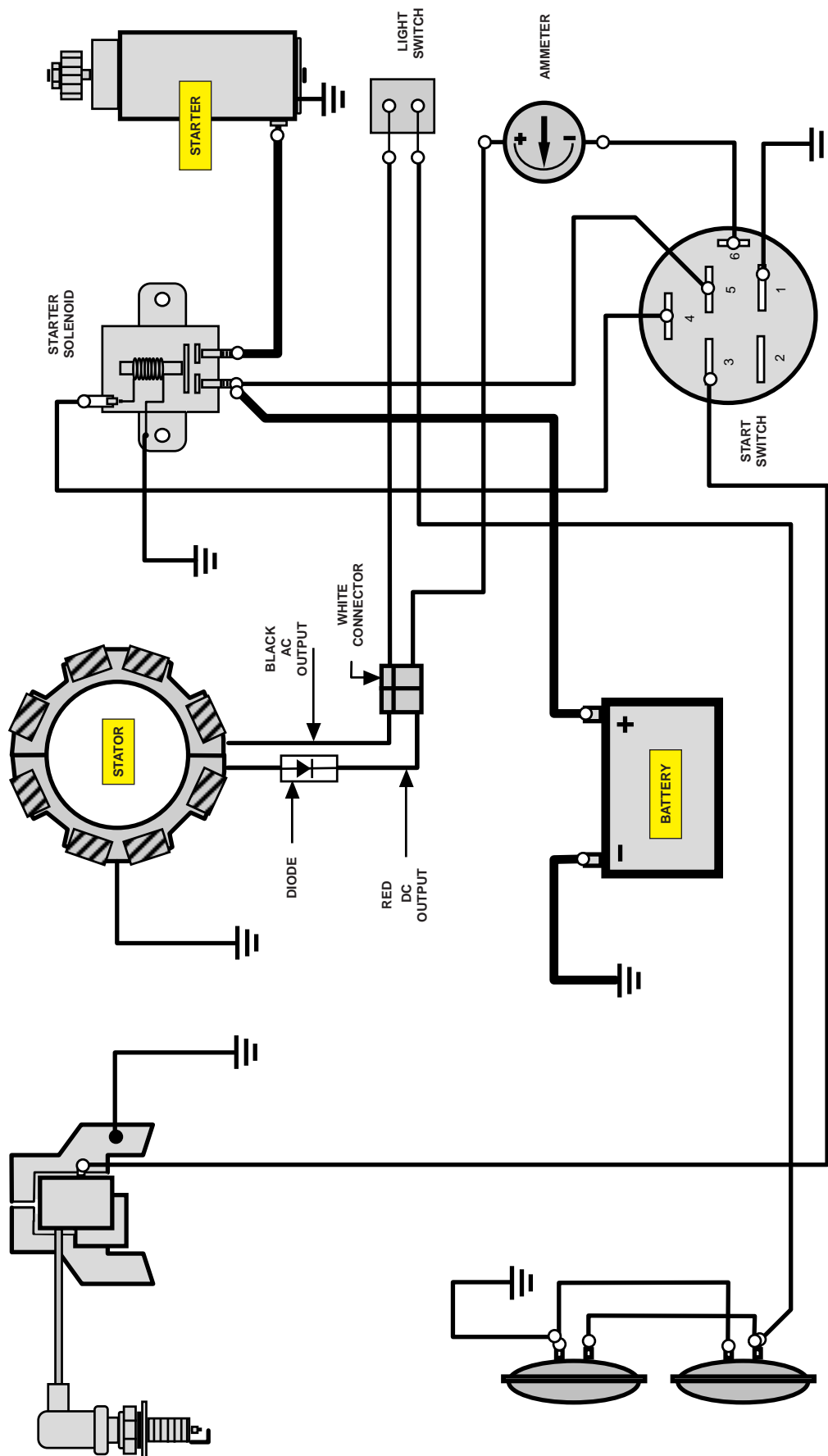

Typical Dual Circuit System

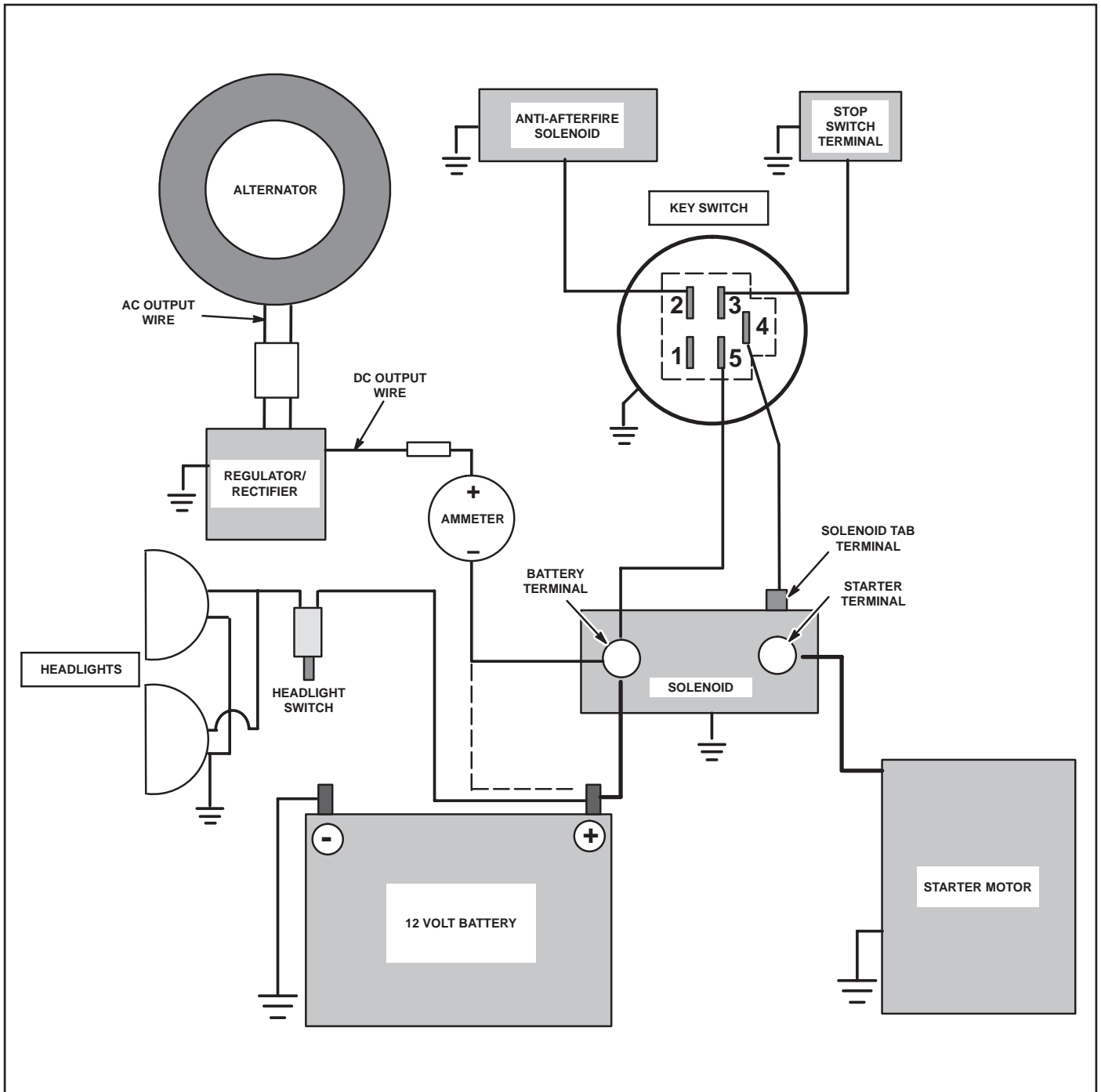

**Typical 16 Amp Regulated Alternator
Wiring Diagram
5 Pole Switch – Briggs & Stratton Part Number 692318**

KEY SWITCH TEST	
SWITCH POSITION	CONTINUITY
1. OFF	*1 + 3
2. RUN	2 + 5
3. START	2 + 4 + 5

*Terminal 1 Grounded Internally
To Key Switch Case

TERMINAL NO.	FUNCTION
1	Ground (Used only with insulated panel)
2	To Carburetor Solenoid
3	To Stop Switch Terminal On Engine
4	To Solenoid (Tab terminal)
5	To Battery (Battery terminal on solenoid)

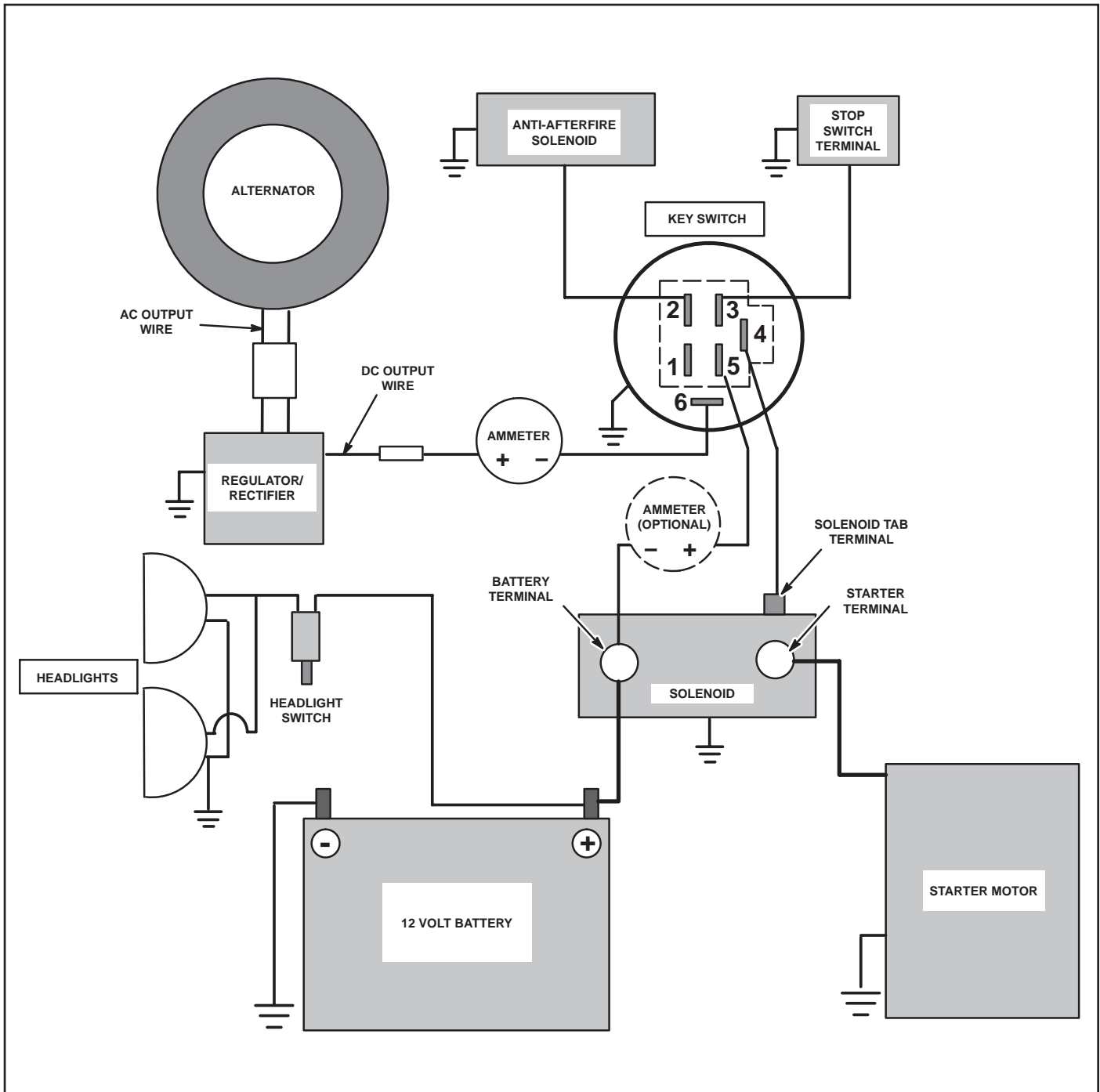

**Typical 16 Amp Regulated Alternator
Wiring Diagram
6 Pole Switch – Briggs & Stratton Part Number 692318**

With ammeter shown in optional position, note that - and + symbols are reversed. The + symbol must always be connected to the alternator side.

KEY SWITCH TEST	
SWITCH POSITION	CONTINUITY
1. OFF	*1 + 3 + 6
2. RUN	2 + 5 + 6
3. START	2 + 4 + 5

*Terminal 1 Grounded Internally
To Key Switch Case

TERMINAL NO.	FUNCTION
1	Ground (Used only with insulated panel)
2	To Carburetor Solenoid
3	To Stop Switch Terminal On Engine
4	To Solenoid (Tab terminal)
5	To Battery (Battery terminal on solenoid)
6	To Alternator (DC Output)

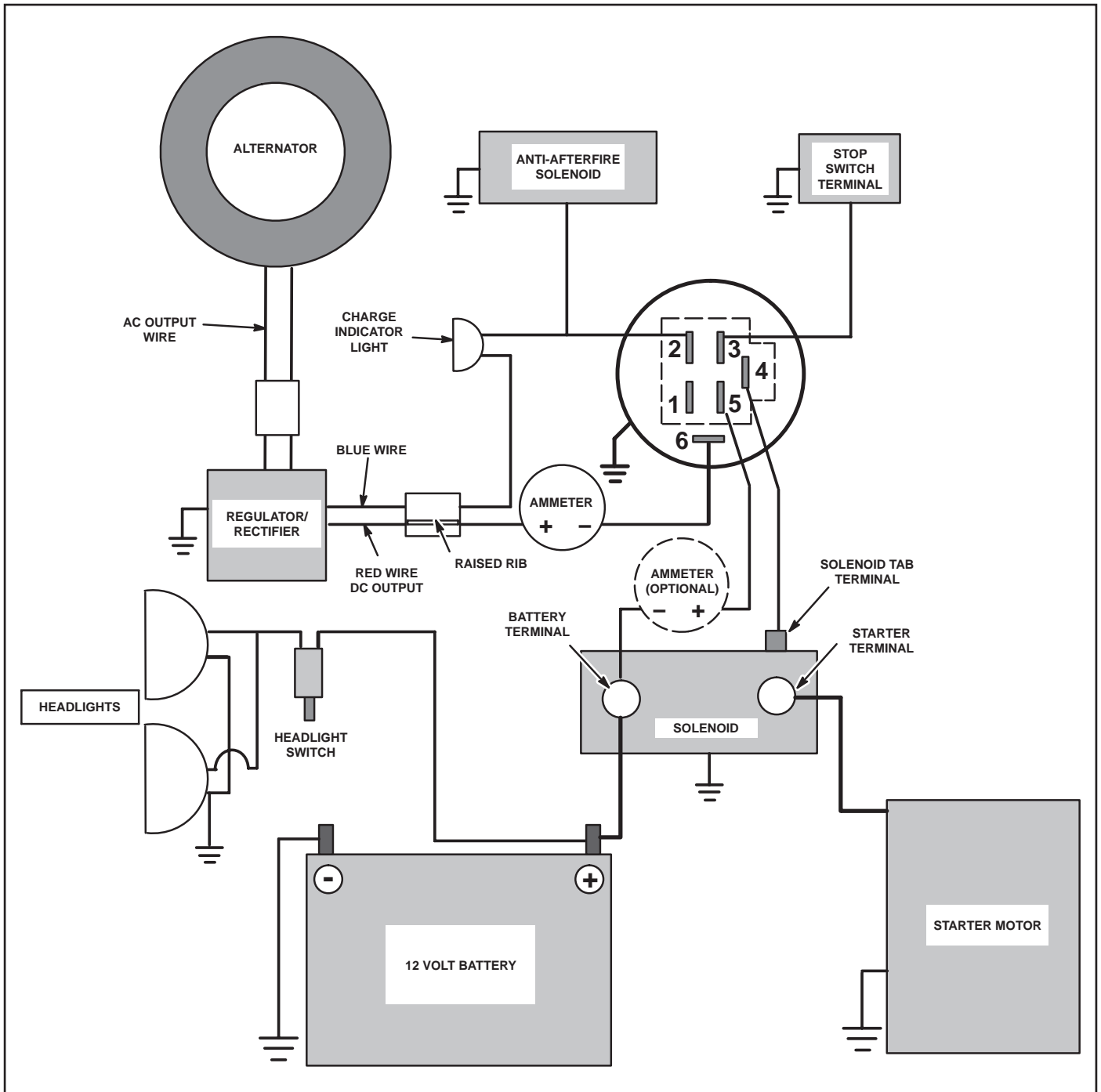

**Typical 16 Amp Regulated Alternator Wiring Diagram
With Charge Indicator Light
6 Pole Switch – Briggs & Stratton Part Number 692318**

With ammeter shown in optional position, note that - and + symbols are reversed. The + symbol must always be connected to the alternator side.

KEY SWITCH TEST	
SWITCH POSITION	CONTINUITY
1. OFF	*1 + 3 + 6
2. RUN	2 + 5 + 6
3. START	2 + 4 + 5

*Terminal 1 Grounded Internally
To Key Switch Case

TERMINAL NO.	FUNCTION
1	Ground (Used only with insulated panel)
2	To Carburetor Solenoid
3	To Stop Switch Terminal On Engine
4	To Solenoid (Tab terminal)
5	To Battery (Battery terminal on solenoid)
6	To Alternator (DC Output)

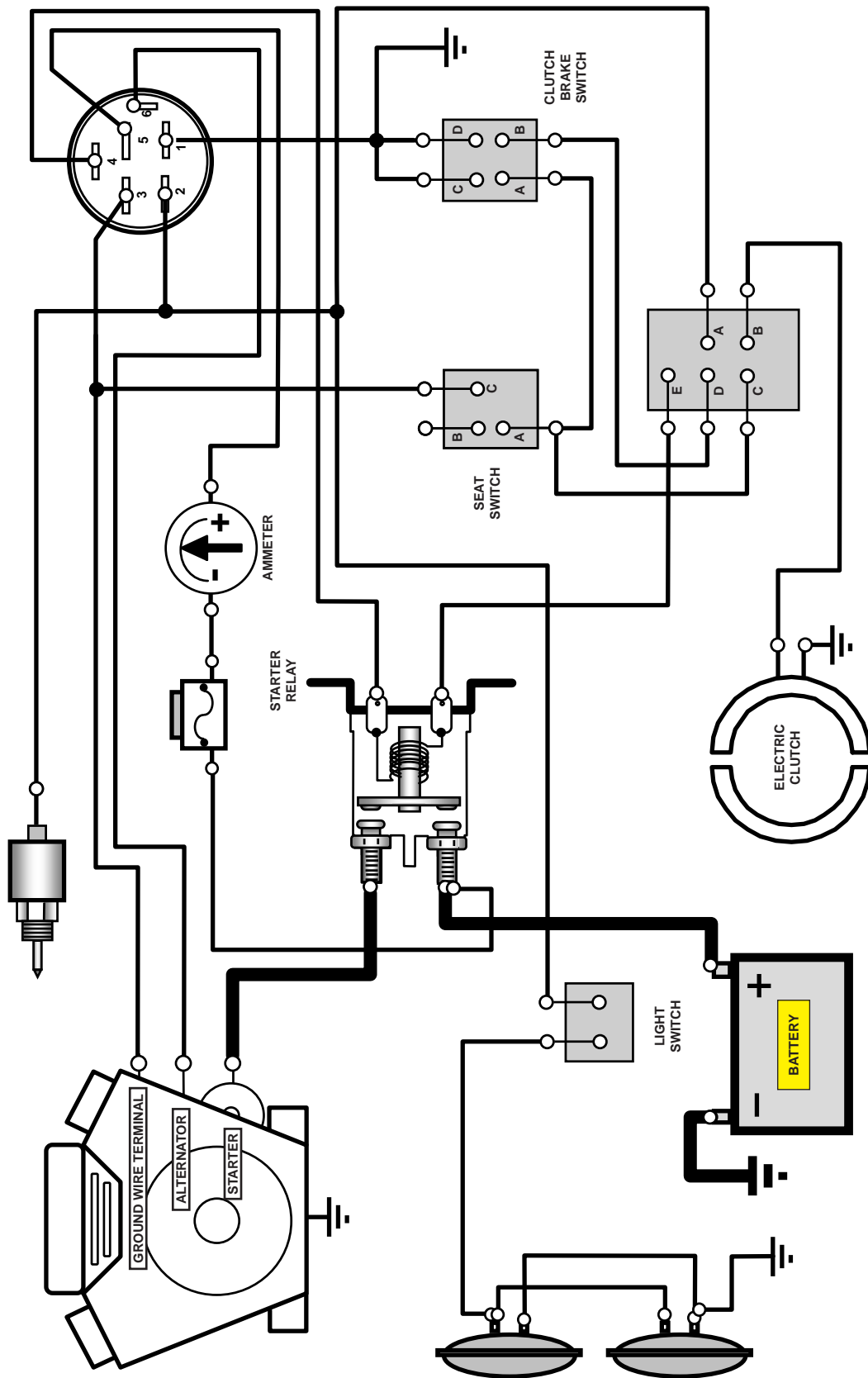

Typical 10/16 Amp System

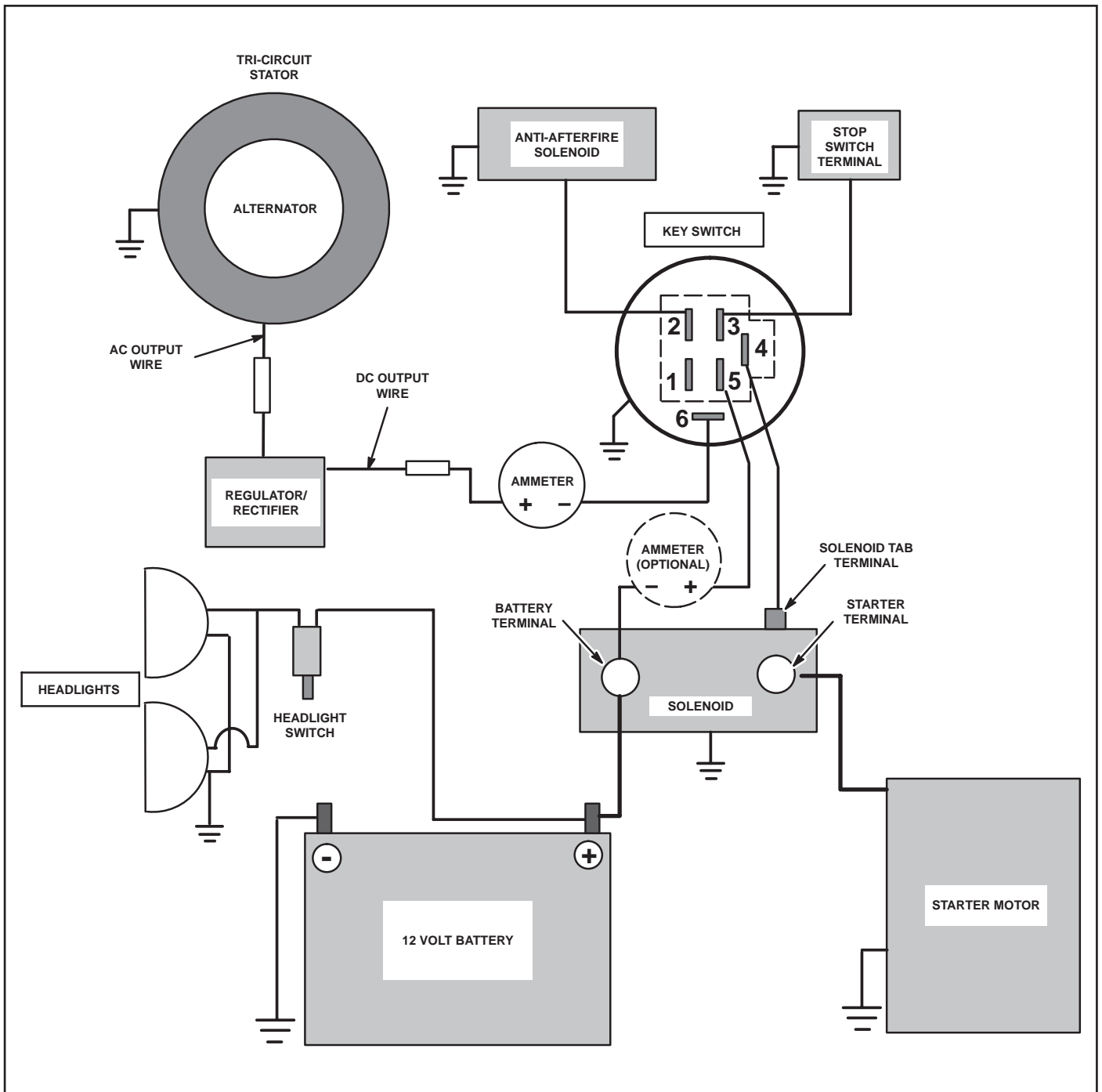

**Typical 5/9 Amp Regulated Alternator Wiring Diagram
With Charge Indicator Light
6 Pole Switch – Briggs & Stratton Part Number 692318**

With ammeter shown in optional position, note that - and + symbols are reversed. The + symbol must always be connected to the alternator side.

KEY SWITCH TEST	
SWITCH POSITION	CONTINUITY
1. OFF	*1 + 3 + 6
2. RUN	2 + 5 + 6
3. START	2 + 4 + 5

*Terminal 1 Grounded Internally
To Key Switch Case

TERMINAL NO.	FUNCTION
1	Ground (Used only with insulated panel)
2	To Carburetor Solenoid
3	To Stop Switch Terminal On Engine
4	To Solenoid (Tab terminal)
5	To Battery (Battery terminal on solenoid)
6	To Alternator (DC Output)

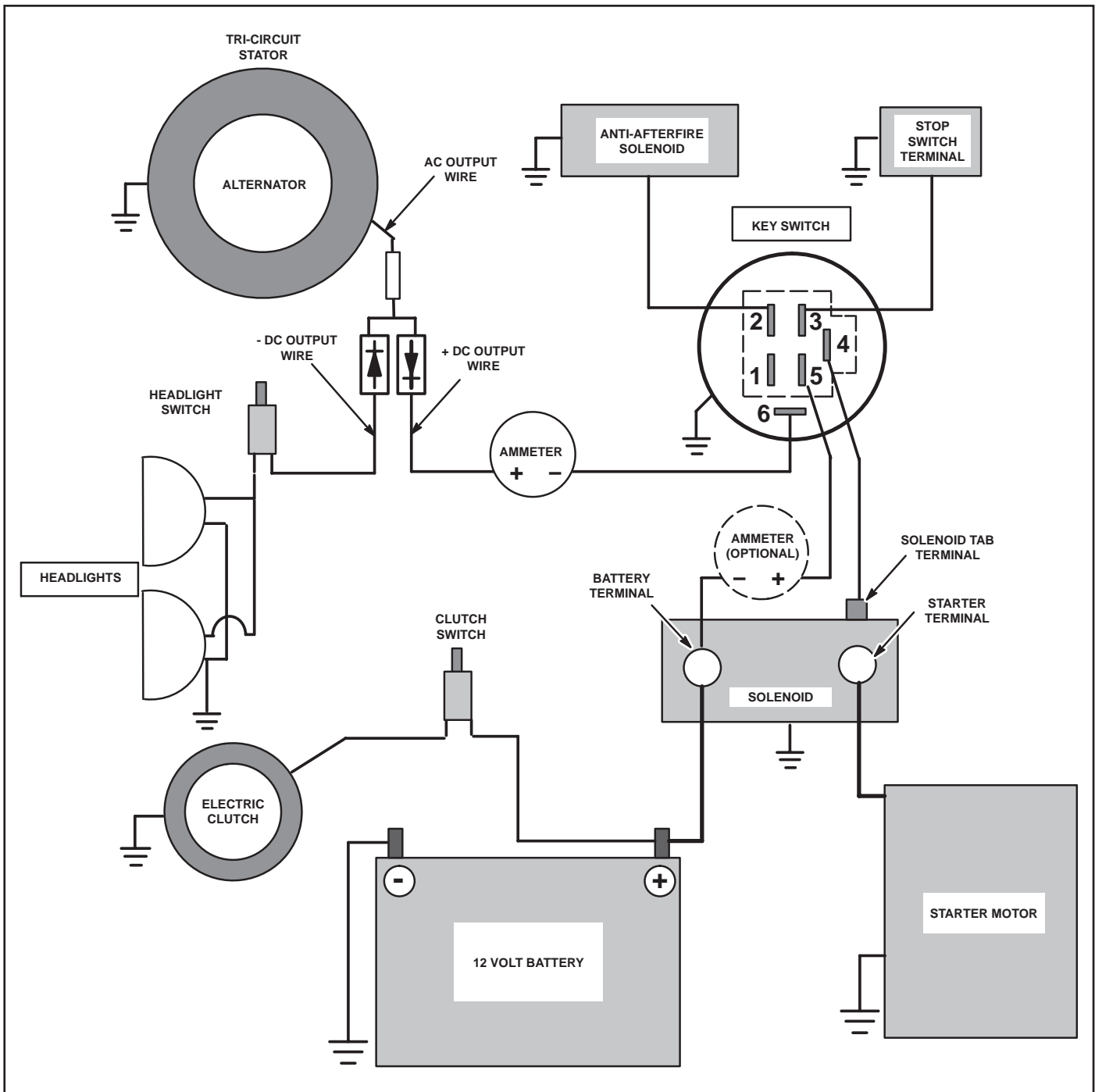

Typical Tri-Circuit Alternator
Wiring Diagram

6 Pole Switch – Briggs & Stratton Part Number 692318

With ammeter shown in optional position, note that - and + symbols are reversed. The + symbol must always be connected to the alternator side.

KEY SWITCH TEST	
SWITCH POSITION	CONTINUITY
1. OFF	*1 + 3 + 6
2. RUN	2 + 5 + 6
3. START	2 + 4 + 5

*Terminal 1 Grounded Internally
To Key Switch Case

TERMINAL NO.	FUNCTION
1	Ground (Used only with insulated panel)
2	To Carburetor Solenoid
3	To Stop Switch Terminal On Engine
4	To Solenoid (Tab terminal)
5	To Battery (Battery terminal on solenoid)
6	To Alternator (DC Output)

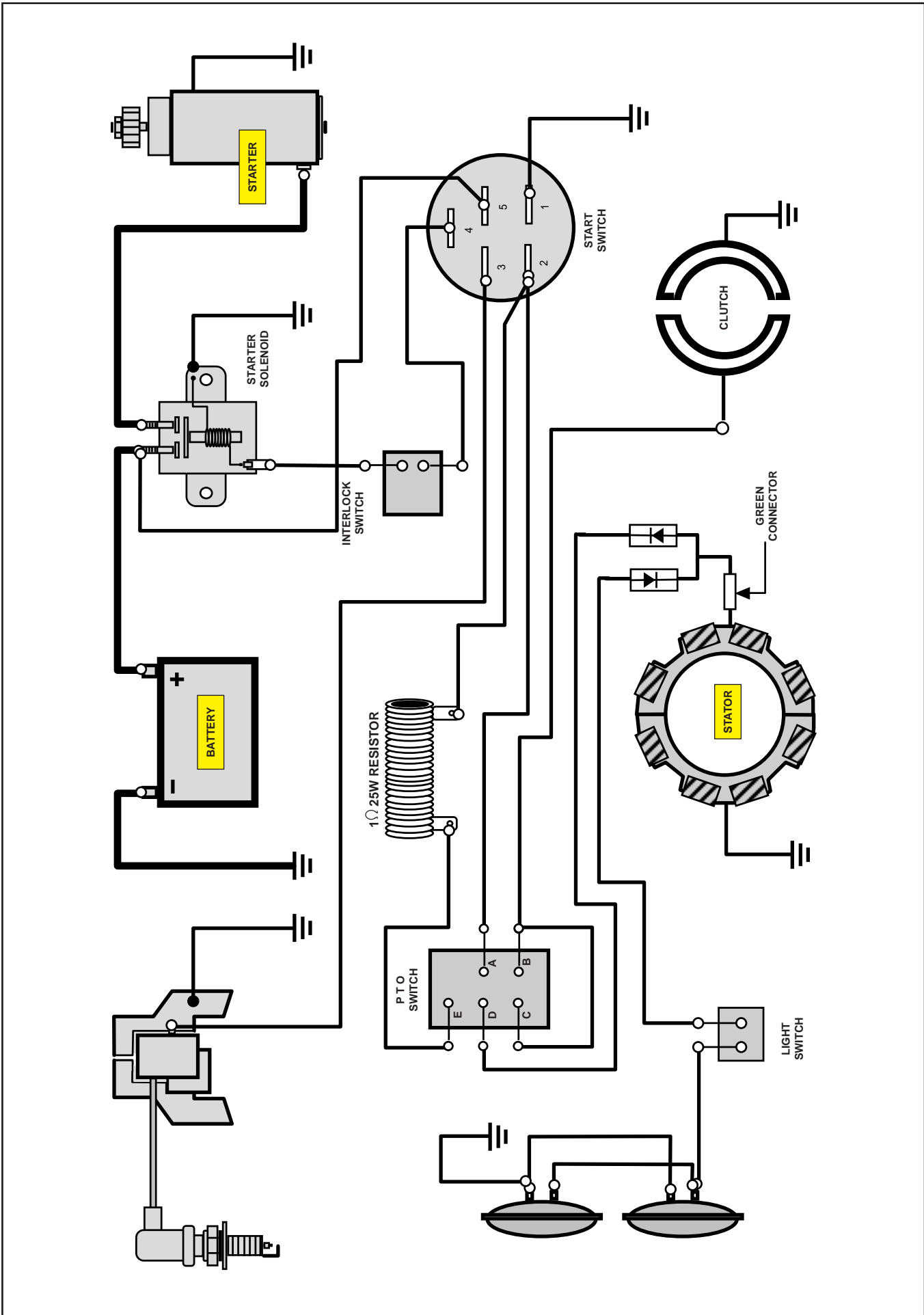

Simplified "Tri-Circuit" System

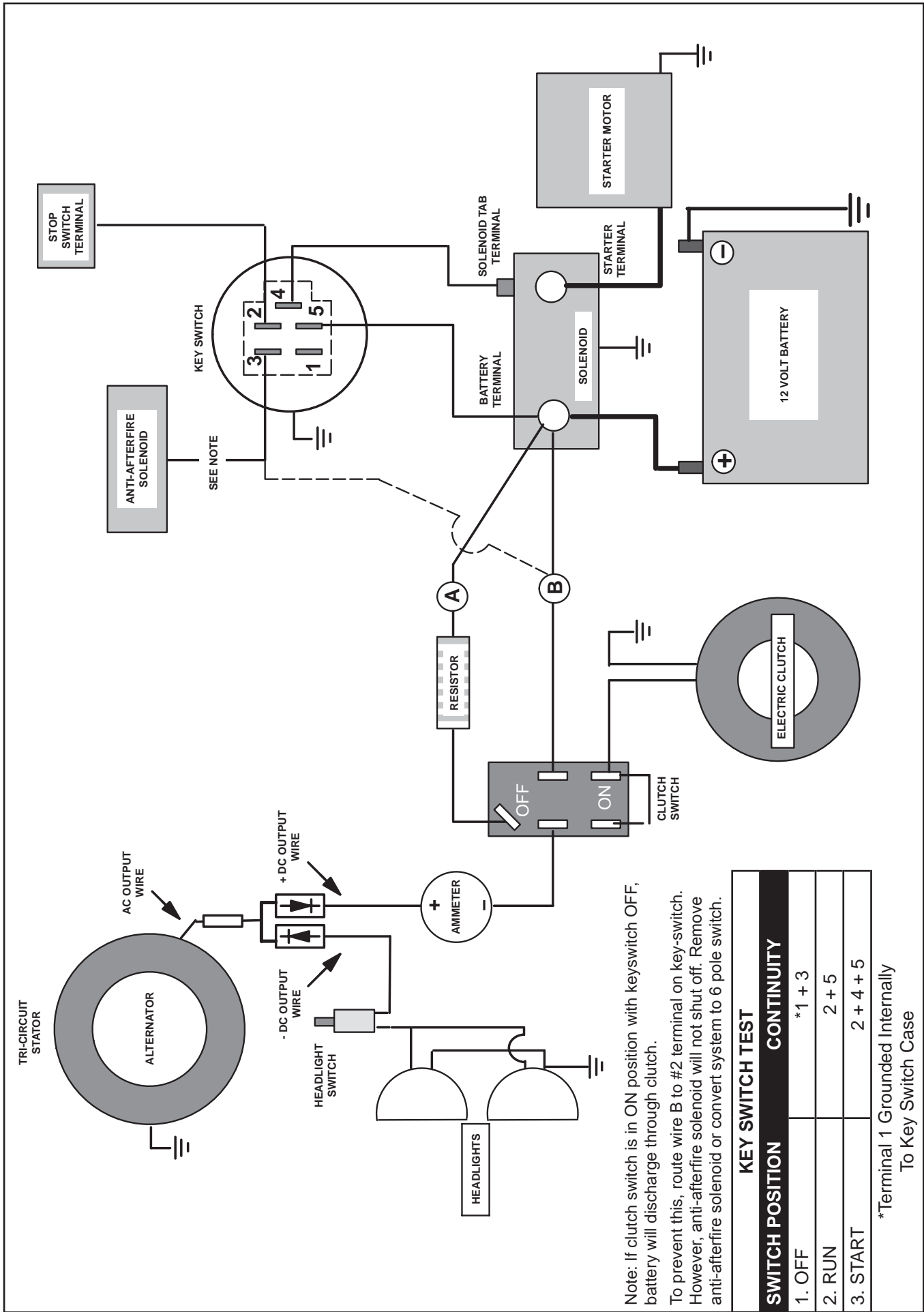

Typical Tri-Circuit Alternator Wiring Diagram – With Resistor – 5 Pole Switch – Briggs & Stratton Part Number 692318

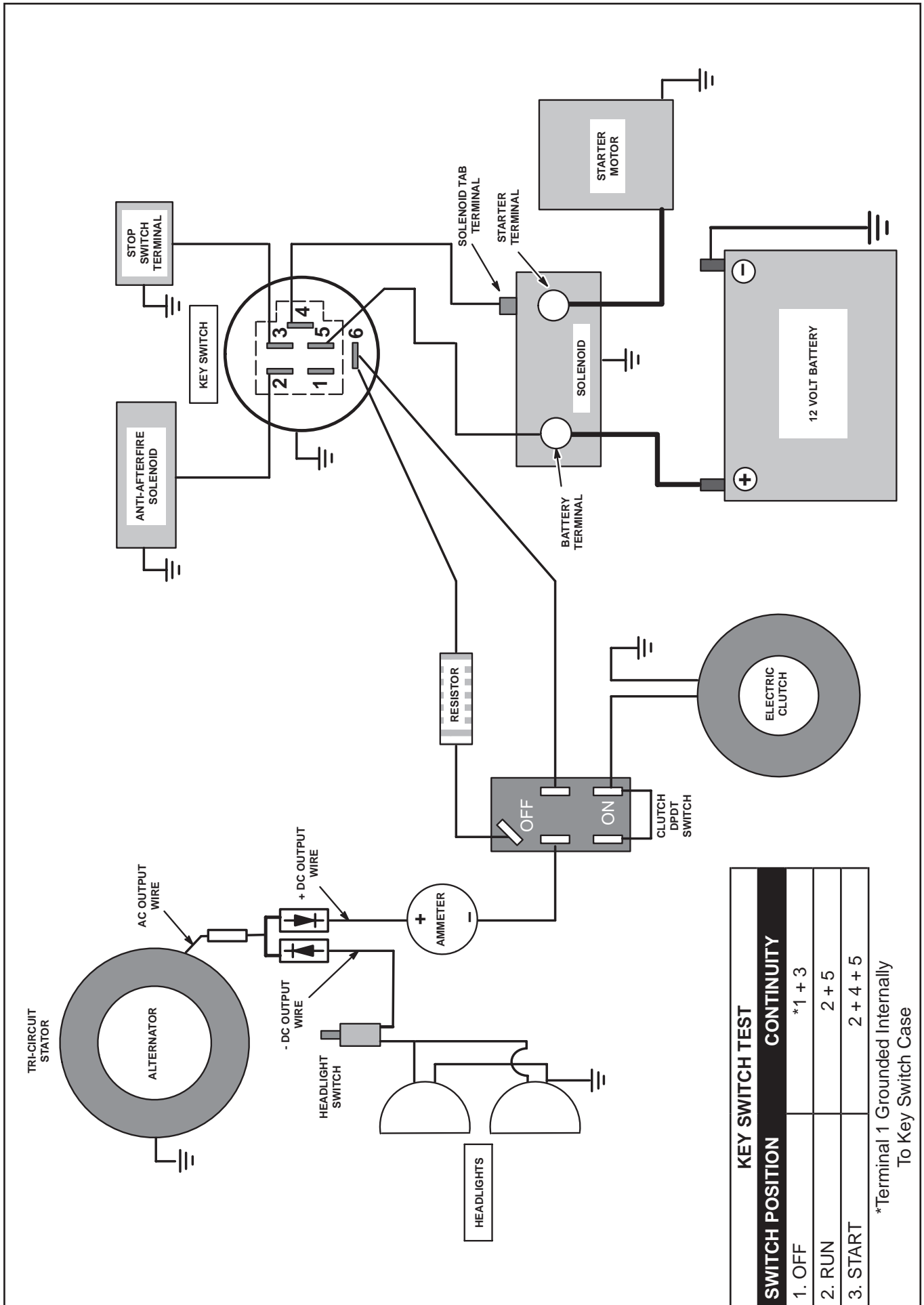

Typical Tri-Circuit Alternator Wiring Diagram – With Resistor – 6 Pole Switch – Briggs & Stratton Part Number 692318

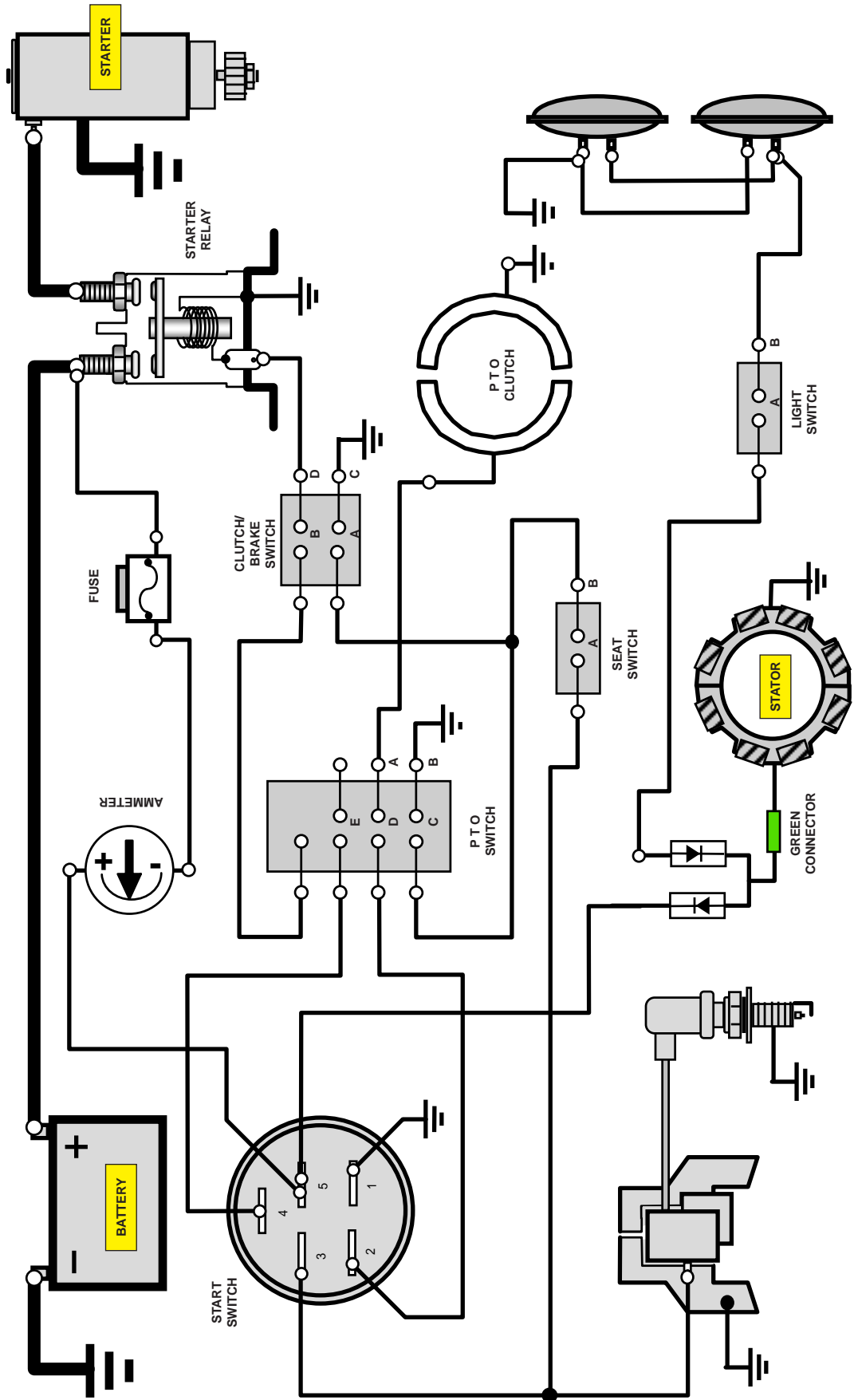

Typical Complex Tri-Circuit System

V-TWIN WIRE HARNESS			
DESCRIPTION	M40/44 WITH #2 SIDE REGULATOR, W/O EFM	M49 WITH #1 SIDE REGULATOR, W/O EFM	M40/44/49 WITH #1 SIDE REGULATOR, WITH EFM
2 pin, standard	499235	499235	796393
Used with (RED, regulator out) (Jumper Wire)	499813	796452	796452
6 pin, standard	694215	795359	796374
6 pin with oil pressure switch	694216	795360	796375
6 pin with hour meter or oil minder	696505	795361	796376
Used with 694215, 694216 and 696505. RED wire from regulator to 2 pin	694214		
ASSOCIATED PARTS			
Shield/Nut Assembly #1 side	693876	795703	795703
Bracket, Hold Down (wire)	na	227680	227680
Tie wrap for regulator wires (inside blower)	na	yes	yes

TYPICAL 6-PIN CONNECTOR

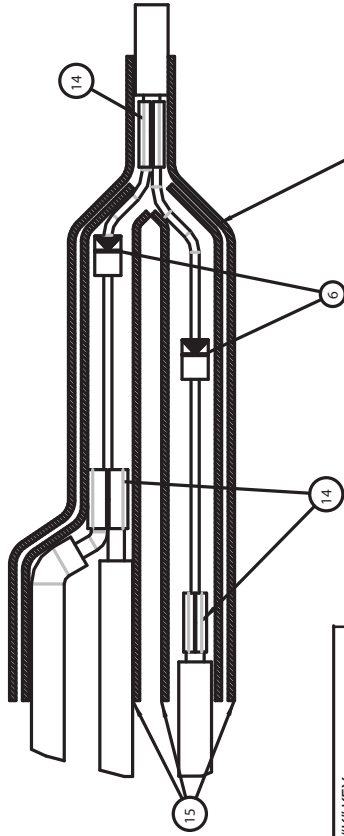
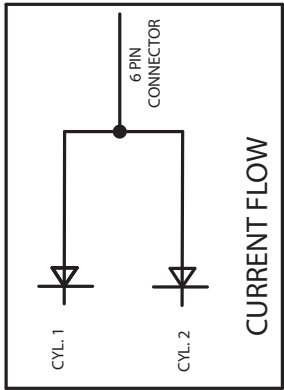

EACH DIODE ASSEMBLY MUST BE INDIVIDUALLY WRAPPED IN SHRINK TUBING. AN ADDITIONAL SHRINK WRAP MUST ALSO BE ASSEMBLED OVER BOTH DIODE ASSEMBLIES.

DETAIL "K" KEY

6	DIODES
14	CRIMPED CONNECTION
15	SHRINK TUBING

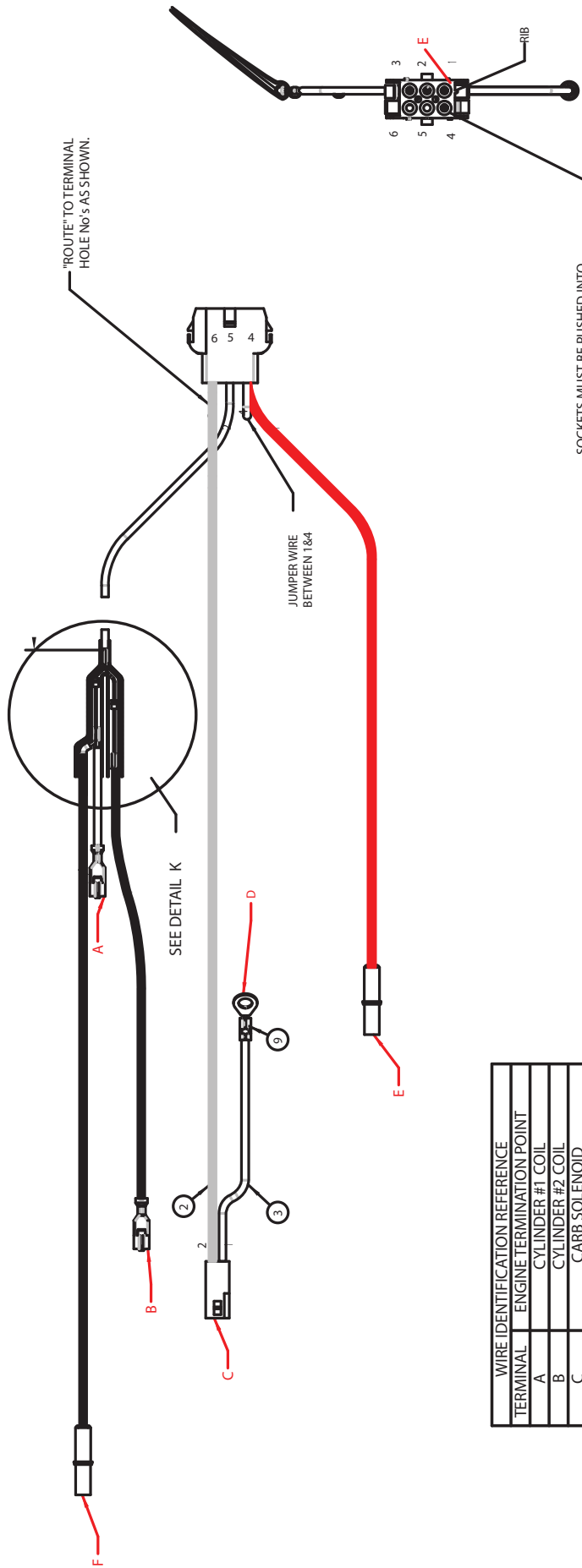

SOCKETS MUST BE PUSHED INTO HOUSING UNTIL TANGS SNAP OPEN OVER PLASTIC TO INSURE THAT SOCKETS CANNOT BACK OUT (4 PLACES)

WIRE IDENTIFICATION REFERENCE	TERMINAL	ENGINE TERMINATION POINT
A	6	CYLINDER #1 COIL
B	5	CYLINDER #2 COIL
C	4	CARB SOLENOID
D	3	GROUND
E	2	POWER SUPPLY TO REGULATOR
F	1	EFM IGNITION PULSE

6-PIN WIRE HARNESS WITH EFM

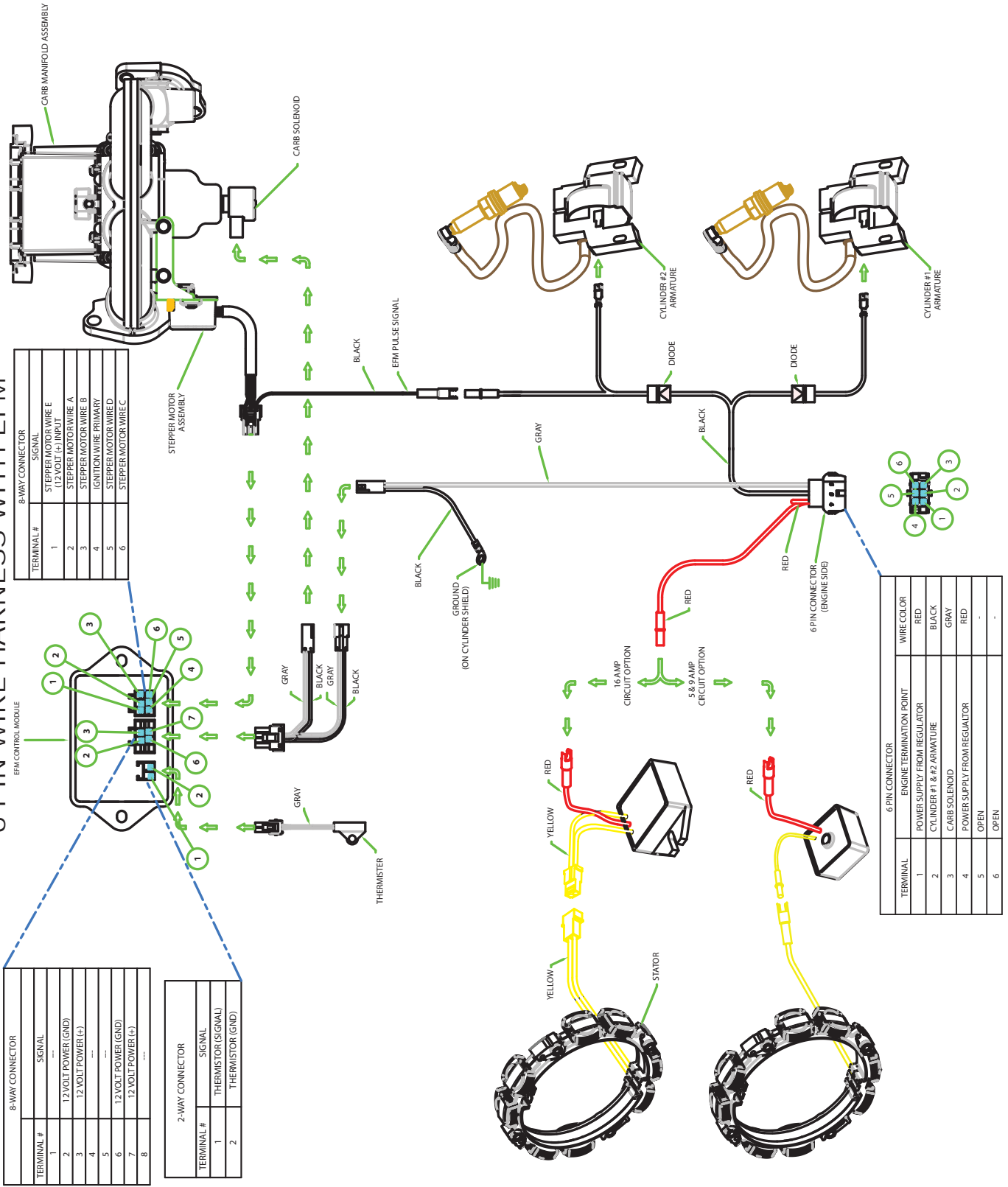

TERMINAL #	SIGNAL
1	STEPPER MOTOR WIRE E (12 VOLT (+) INPUT)
2	STEPPER MOTOR WIRE A
3	STEPPER MOTOR WIRE B
4	IGNITION WIRE PRIMARY
5	STEPPER MOTOR WIRE D
6	STEPPER MOTOR WIRE C

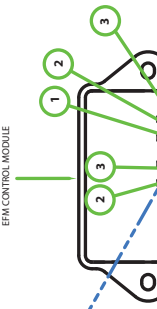

TERMINAL #	SIGNAL
1	---
2	12 VOLT POWER (GND)
3	12 VOLT POWER (+)
4	---
5	---
6	12 VOLT POWER (GND)
7	12 VOLT POWER (+)
8	---

TERMINAL #	SIGNAL
1	THERMISTOR (SIGNAL)
2	THERMISTOR (GND)

TERMINAL	ENGINE TERMINATION POINT	WIRE COLOR
1	POWER SUPPLY FROM REGULATOR	RED
2	CYLINDER #1 & #2 ARMATURE	BLACK
3	CARB SOLENOID	GRAY
4	POWER SUPPLY FROM REGULATOR	RED
5	OPEN	-
6	OPEN	-

WIRE CONNECTORS

V-TWIN 6 PIN CONNECTOR

ENGINE CONNECTION

AMP PIN HOUSING (FEMALE-CAP)

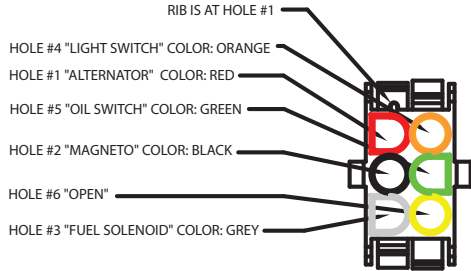

APPLICATION CONNECTION

AMP SOCKET HOUSING (MALE-PLUG)

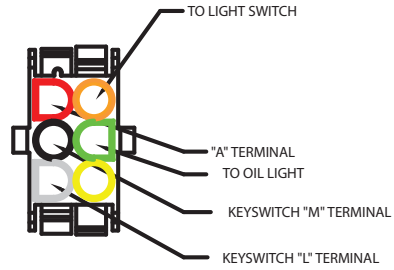

V-TWIN WITH DUAL 2 PIN CONNECTORS

ENGINE CONNECTION

AMP PIN HOUSING (FEMALE-CAP)

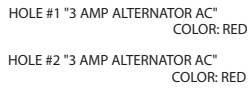

APPLICATION CONNECTION

AMP SOCKET HOUSING (MALE-PLUG)

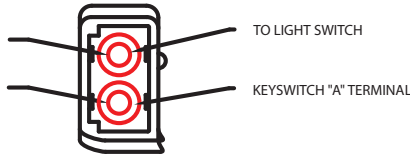

ENGINE CONNECTION

AMP SOCKET HOUSING (MALE-PLUG)

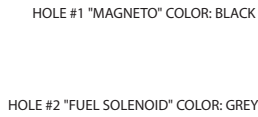

APPLICATION CONNECTION

AMP PIN HOUSING (FEMALE-CAP)

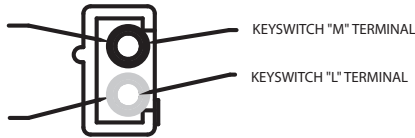

V-TWIN WITH 2 PIN CONNECTOR AND 1 PIN CONNECTOR

ENGINE CONNECTION

AMP SOCKET HOUSING (MALE-PLUG)



APPLICATION CONNECTION

AMP PIN HOUSING (FEMALE-CAP)

ENGINE CONNECTION

AMP SOCKET HOUSING (MALE-PLUG)

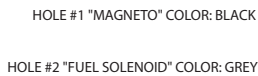

APPLICATION CONNECTION

AMP PIN HOUSING (FEMALE-CAP)

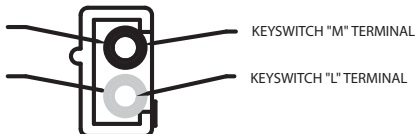

TYPICAL 8-PIN CONNECTOR

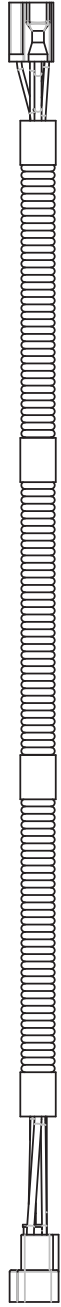

Left Side View

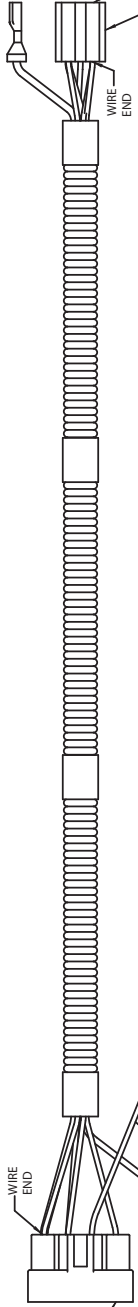

Top View

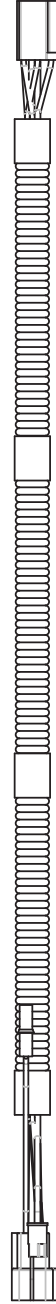
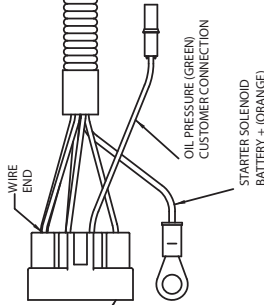
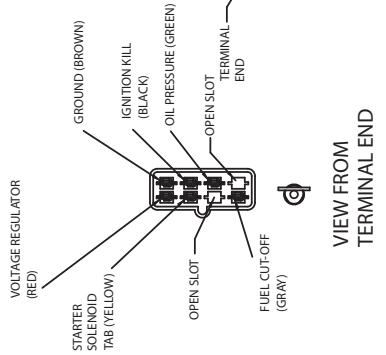

Right Side View

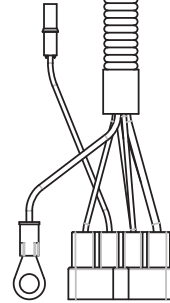

Bottom View

PERFORMANCE CONTROL™ ELECTRONIC GOVERNOR

Some Vanguard™ V-Twin engines are equipped with the Performance Control™ electronic governor control system for generator or welder applications. The electronic governor provides more responsive governing than a mechanical governor system. Engines equipped with the Performance Control™ electronic governor control system have no mechanical governor components. The Performance Control™ electronic governor control system cannot be retrofitted to mechanical governor engines.

The Performance Control™ electronic governor control system consists of an electronic control module, wiring and stop switch harness and a throttle actuator. The control module is equipped with an idle down circuit for applications requiring that feature. By cutting the yellow wire loop, the control module may be converted to 50 cycle – 3000 RPM generator applications. The engine must be turned off when cutting Yellow Cycle loop, then start the engine for the system to reset the engines RPM for 50Hz cycle.

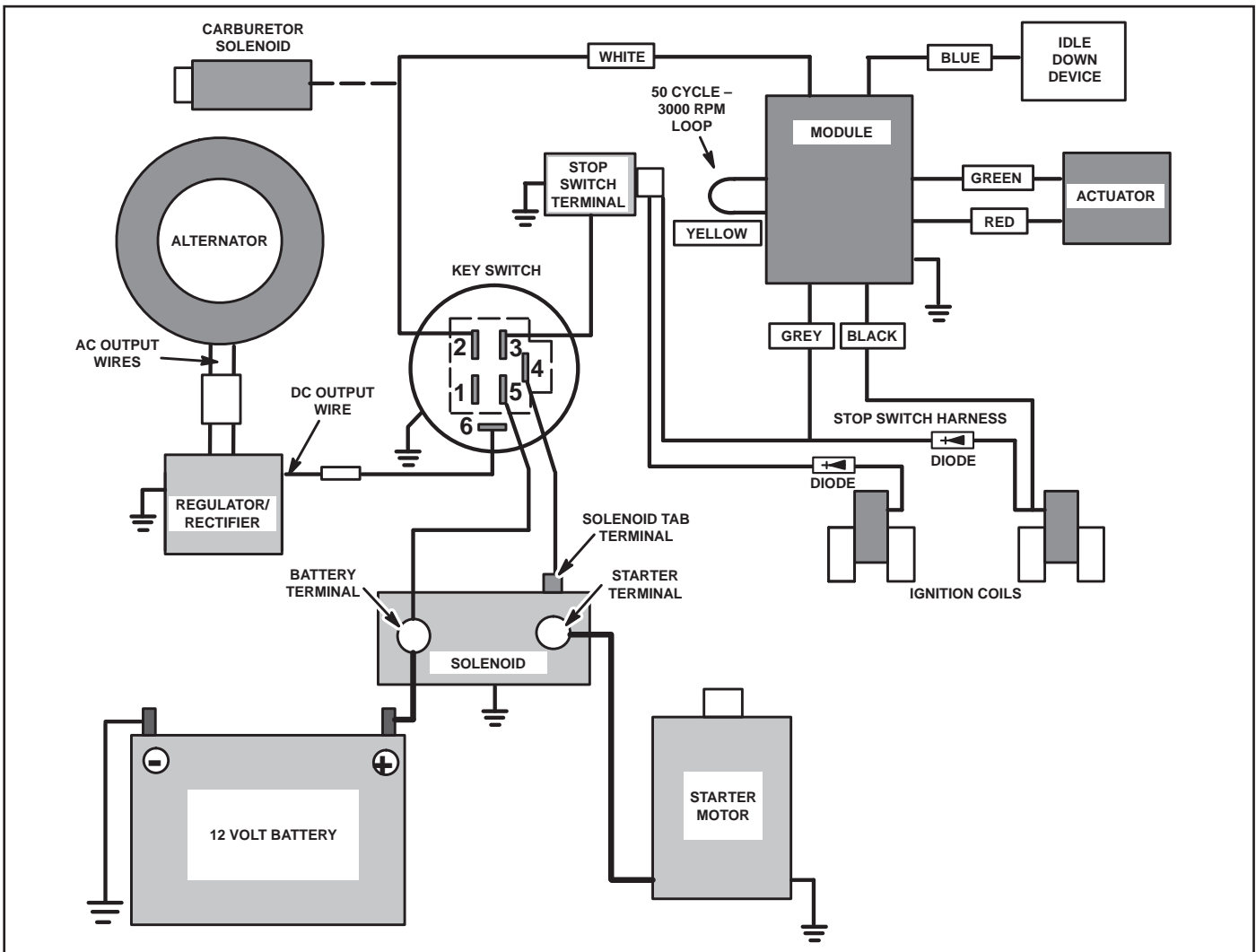

Performance Control™ Electronic Governor Wiring Diagram

AWG Wire Sizes (see table on the next page)

AWG: In the American Wire Gauge (AWG), diameters can be calculated by applying the formula $D(\text{AWG}) = .005 \cdot 92 \left(\frac{36 - \text{AWG}}{39} \right)$ inch. For the 00, 000, 0000 etc. gauges you use -1, -2, -3, which makes more sense mathematically than “double nought.” This means that in American wire gage every 6 gauge decrease gives a doubling of the wire diameter, and every 3 gauge decrease doubles the wire cross sectional area. Similar to dB in signal and power levels. An approximate form of this formula contributed by Mario Rodriguez is $D = .460 * (57/64)(\text{awg} + 3)$ or $D = .460 * (0.890625)(\text{awg} + 3)$.

Metric Wire Gauges (see table on the next page)

Metric Gauge: In the Metric Gauge scale, the gauge is 10 times the diameter in millimeters, so a 50 gauge metric wire would be 5 mm in diameter. Note that in AWG the diameter goes up as the gauge goes down, but for metric gauges it is the opposite. Probably because of this confusion, most of the time metric sized wire is specified in millimeters rather than metric gauges.

Load Carrying Capacities (see table on the next page)

The following chart is a guideline of ampacity or copper wire current carrying capacity following the Handbook of Electronic Tables and Formulas for American Wire Gauge. As you might guess, the rated ampacities are just a rule of thumb. In careful engineering the voltage drop, insulation temperature limit, thickness, thermal conductivity, and air convection and temperature should all be taken into account. The Maximum Amps for Power Transmission uses the 700 circular mils per amp rule, which is very conservative. The Maximum Amps for Chassis Wiring is also a conservative rating, but is meant for wiring in air, and not in a bundle. For short lengths of wire, such as is used in battery packs you should trade off the resistance and load with size, weight, and flexibility. NOTE: For installations that need to conform to the National Electrical Code, you must use their guidelines. Contact your local electrician to find out what is legal!

AWG gauge	Conductor Diameter Inches	Conductor Diameter mm	Ohms per 1000 ft.	Ohms per km	Maximum amps for chassis wiring	Maximum amps for power transmission	Maximum frequency for 100% skin depth for solid conductor copper
0000	0.46	11.684	0.049	0.16072	380	302	125 Hz
000	0.4096	10.40384	0.0618	0.202704	328	239	160 Hz
00	0.3648	9.26592	0.0779	0.255512	283	190	200 Hz
0	0.3249	8.25246	0.0983	0.322424	245	150	250 Hz
1	0.2893	7.34822	0.1239	0.406392	211	119	325 Hz
2	0.2576	6.54304	0.1563	0.512664	181	94	410 Hz
3	0.2294	5.82676	0.197	0.64616	158	75	500 Hz
4	0.2043	5.18922	0.2485	0.81508	135	60	650 Hz
5	0.1819	4.62026	0.3133	1.027624	118	47	810 Hz
6	0.162	4.1148	0.3951	1.295928	101	37	1100 Hz
7	0.1443	3.66522	0.4982	1.634096	89	30	1300 Hz
8	0.1285	3.2639	0.6282	2.060496	73	24	1650 Hz
9	0.1144	2.90576	0.7921	2.598088	64	19	2050 Hz
10	0.1019	2.58826	0.9989	3.276392	55	15	2600 Hz
11	0.0907	2.30378	1.26	4.1328	47	12	3200 Hz
12	0.0808	2.05232	1.588	5.20864	41	9.3	4150 Hz
13	0.072	1.8288	2.003	6.56984	35	7.4	5300 Hz
14	0.0641	1.62814	2.525	8.282	32	5.9	6700 Hz
15	0.0571	1.45034	3.184	10.44352	28	4.7	8250 Hz
16	0.0508	1.29032	4.016	13.17248	22	3.7	11 kHz
17	0.0453	1.15062	5.064	16.60992	19	2.9	13 kHz
18	0.0403	1.02362	6.385	20.9428	16	2.3	17 kHz
19	0.0359	0.91186	8.051	26.40728	14	1.8	21 kHz
20	0.032	0.8128	10.15	33.292	11	1.5	27 kHz
21	0.0285	0.7239	12.8	41.984	9	1.2	33 kHz
22	0.0254	0.64516	16.14	52.9392	7	0.92	42 kHz
23	0.0226	0.57404	20.36	66.7808	4.7	0.729	53 kHz
24	0.0201	0.51054	25.67	84.1976	3.5	0.577	68 kHz
25	0.0179	0.45466	32.37	106.1736	2.7	0.457	85 kHz
26	0.0159	0.40386	40.81	133.8568	2.2	0.361	107 kHz
27	0.0142	0.36068	51.47	168.8216	1.7	0.288	130 kHz
28	0.0126	0.32004	64.9	212.872	1.4	0.226	170 kHz
29	0.0113	0.28702	81.83	268.4024	1.2	0.182	210 kHz
30	0.01	0.254	103.2	338.496	0.86	0.142	270 kHz
31	0.0089	0.22606	130.1	426.728	0.7	0.113	340 kHz
32	0.008	0.2032	164.1	538.248	0.53	0.091	430 kHz
Metric 2.0	0.00787	0.200	169.39	555.61	0.51	0.088	440 kHz
33	0.0071	0.18034	206.9	678.632	0.43	0.072	540 kHz
Metric 1.8	0.00709	0.180	207.5	680.55	0.43	0.072	540 kHz
34	0.0063	0.16002	260.9	855.752	0.33	0.056	690 kHz
Metric 1.6	0.0063	0.16002	260.9	855.752	0.33	0.056	690 kHz
35	0.0056	0.14224	329	1079.12	0.27	0.044	870 kHz
Metric 1.4	.00551	.140	339	1114	0.26	0.043	900 kHz
36	0.005	0.127	414.8	1360	0.21	0.035	1100 kHz
Metric 1.25	.00492	0.125	428.2	1404	0.20	0.034	1150 kHz
37	0.0045	0.1143	523.1	1715	0.17	0.0289	1350 kHz
Metric 1.12	.00441	0.112	533.8	1750	0.163	0.0277	1400 kHz
38	0.004	0.1016	659.6	2163	0.13	0.0228	1750 kHz
Metric 1	.00394	0.1000	670.2	2198	0.126	0.0225	1750 kHz
39	0.0035	0.0889	831.8	2728	0.11	0.0175	2250 kHz
40	0.0031	0.07874	1049	3440	0.09	0.0137	2900 kHz

Alternator & Connector		Tester Settings			Tester Leads			Speed & Readings
SYSTEM 3 & 4 also quantum 120000 1/2 amp DC			Amps DC				2,800rpm 0.5 amps DC minimum	
DC only 1.2 amp DC			Amps DC				3,600rpm 1.0 amps DC minimum	
DC only 1.5 amp DC			Amps DC				3,600rpm 1.2 amps DC minimum	
AC only 14 volts AC			Volts AC				3,600rpm 14 volts AC minimum	
DC only 2-4 amps DC			Amps DC				3,600rpm 2 to 4 amps DC	
Dual Circuit 2-4 amps DC 14 volts AC			Amps DC				3,600rpm 2 to 4 amps DC	
Tri Circuit 28 volts AC			Volts AC				3,600rpm 14 volts AC minimum	
Regulated one output pin			300mV DC				3,600rpm up to 5 amps for battery Refer to service & repair instructions for additional information	
Regulated two output pin			Volts AC				3,600rpm 28 volts AC minimum for 5 amp 40 volts AC minimum for 9 amp	
Regulated two output pin			Volts AC				3,600rpm Test with regulator fully wired. Output up to 5 or 9 amps according to battery state	
Regulated two output pins with heat sink			300mV DC				3,600rpm 20 volts AC minimum for 10 & 13 amp 30 volts AC minimum for 16 amp	
			Volts AC				3,600rpm Test with regulator fully wired. Output up to 10/13/16 amps according to battery state	
			Volts AC				3,600rpm 26 volt AC minimum	
			300mV DC				3,600rpm Test with regulator fully wired. Output up to 20 amps according to battery state	

GLOSSARY OF TERMS

In this day of lightning fast communications and an ever increasing level of sophistication in our day to day activities, the spoken word has become one of the most important tools in our toolboxes. "Word Power" is the natural extension of your thought processes. Without a high caliber vocabulary, communication with our peers and/or our customers can be severely hampered. Customers will measure us more than we might imagine, when we are unable to express our knowledge and expertise accurately and concisely. Exercising the vocabulary is every bit as important as learning the latest new service procedure.

A

AC sine wave: A symmetrical wave form that contains 360 degrees.

AC voltage test: A test that uses a volt meter to indicate the voltage potential of the alternator stator.

alternating current (AC): A flow of electrons that reverses direction at regular intervals.

alternator: A charging system device that produces AC voltage and amperage.

amperage: The strength or intensity of an electric current, measured in amperes (AMPS).

amperes: The measurement of the number of electrons flowing through a conductor per unit of time.

armature: A rotating part of a DC motor that consists of wire wound around an armature shaft.

atom: A small unit of a material that consists of protons, electrons, and neutrons.

automatic switch (circuit breaker, fuse): A switch that stops the flow of current any time current limits are reached.

B

battery: An electrical energy storage device.

battery charge rectifier: A component which changes AC voltage from the battery charge windings (within the STATOR) to DC voltage. This voltage could be used to charge a battery.

battery loading device: An electrical test tool that applies an electrical load to the battery while measuring amperage and voltage.

breaker point ignition system: An ignition system that uses a mechanical switch to control timing of ignition.

breaker points: An ignition system component that has two points (contact surfaces) that function as a mechanical switch.

bridge rectifier: A device that uses four interconnected diodes to change one cycle of AC current into two DC pulses.

brushes: Carbon components, in contact with the commutator, that carry battery current to operate the starter motor.

C

capacitor: An electrical component that stores voltage.

charging system: A system that replenishes the electrical power drawn from the battery during starting and accessory operation.

circuit: A complete path that controls the rate and direction of electron flow on which voltage is applied.

circuit breaker, fuse (automatic switch): A switch that stops the flow of current any time current limits are reached.

coil: A circular wound wire (winding) consisting of insulated conductors arranged to produce lines of magnetic flux.

cold cranking amps (CCA): The number of amps produced by the battery for 30 sec at 0 degrees F (- 18 degrees C.) while maintaining 1.2 V per cell.

commutator: A sectional piece of copper that is directly connected to many loops of copper wire in contact with brushes.

condenser: A capacitor used in an ignition system. It stores voltage and resists any change in voltage.

conduction: Heat transfer that occurs from atom to atom when molecules come in direct contact with each other, and through vibration, when kinetic energy is passed from atom to atom.

conductor: A material that allows the free flow of electrons.

contactor: A contactor is an electrically operated switch usually used in control circuits and whose contacts are considered high amperage compared to a relay.

core: The laminations in the generator constituting the magnetic structure thereof.

cradle: The metal frame that surrounds and protects the generator/engine.

current: The flow of electrons moving past a point in a circuit.

cycle: One complete wave of alternating voltage that contains 360 degrees.

D

DC amperage test: A test that uses a digital multimeter or other suitable test instrument to indicate the current that should enter the battery if all connections to the battery are good.

depletion region: The region of a diode which separates P-type material and N-type material.

digital multimeter (DMM): A test tool used to measure two or more electrical values.

diode: An electrical semiconductor device that can be used to convert AC to DC.

direct current (DC): The flow of electrons in one direction only.

dynamo: A machine for converting mechanical energy into electrical energy by electromagnetic induction – a generator.

E

eddy current: Undesirable current induced in the metal structure of an electrical device due to the rate of change in the induced magnetic field.

electrical symbols: Graphic illustrations used in electrical system diagrams to show the function of a device or component.

electricity: Energy created by the flow of electrons in a conductor.

electric starting system: A group of electrical components activated by the operator to rotate the crankshaft when starting an engine.

electro-motive force (EMF): The force which causes current to flow in a conductor; in other words, the voltage potential.

electrolyte: A mixture of water and sulfuric acid (H₂SO₄) used in a lead-acid battery.

electrons: The parts of an atom that have a negative electrical charge

F

free electron: An electron that is capable of jumping in or out of the outer orbit.

frequency: 1. The number of complete electrical cycles per second (cps).

full-wave rectification: The process of rectifying AC and recovering the B- pulse of AC that the diode blocks.

full power outlet: Enables you to draw the full power of the generator out of one outlet.

fuse: An excess current protection device with a thin metal strip that melts and opens the circuit when a short circuit or excess current condition occurs.

G – I

generator: An electrical device that produces an AC sine wave as a wire coil is rotated in a magnetic field or as magnets are rotated inside a wire coil.

ground: A connection, intentional or accidental, between an electrical circuit and the earth or some conduction body serving in the place of the earth.

half-wave rectifier: An electronic device used in a charging system that converts AC to DC by blocking one-half of the AC sine wave to allow current to flow in only one direction.

hertz (Hz): The international unit of frequency equal to one cycle per second.

horsepower (HP): A unit of power equal to 746 watts (W) or 33,000 lb.-ft. per minute (550 lb.-ft. per second).

idle control: A system that controls the idle speed of the engine in direct relation to the electrical load.

ignition armature: A component containing two or more coils which, when acted upon by a magnetic field, induces electrical energy.

ignition coil: A device used to supply DC voltage to the spark plugs.

ignition system: A system that provides a high voltage spark in the combustion chamber at the proper time.

induction: The production of voltage and current by the proximity and motion of a magnetic field or electric charge.

induction principle: A theory which states that with a conductor, any one of the following (current, a magnetic field, or motion) can be produced by the remaining two.

inductive field coil: A coil of wire, attached to a segmented iron core, that produces a magnetic field when current is passed through it.

ionization gap: The distance between the ignition armature pole and the secondary pole in the spark tester.

L

lamination stack: An electrical component that consists of thin iron layers used to focus and control the lines of magnetic flux.

lead-acid battery: A battery that stores electrical energy using lead cell plates and sulfuric acid (H₂SO₄).

limited angle torque (LAT) motor: A direct current (DC) motor used to control governor system components in an electronic governor system.

load: A device that uses electricity, such as the starter motor, lights, or other application accessories.

M – N

magnet: A material that attracts iron and produces a magnetic field.

magnetic field: An area of magnetic force created and defined by lines of magnetic flux surrounding a material in three dimensions.

magnetic flux: The invisible lines of force in a magnetic field.

magnetism: An atomic level force derived from the atomic structure and motion of certain orbiting electrons in a substance.

magneto: An alternator with permanent magnets used to generate current for ignition in an internal combustion engine.

Magnetron® ignition system: An ignition system that uses electronic components in place of breaker points and a condenser.

manual switch: A switch operated by a person.

mechanical switch: A switch operated by the movement of an object.

milliamp: An expression meaning 1/1000th of an amp.

millivolt: An expression meaning 1/1000th of a volt.

neutrons: The neutral parts of an atom which have no electrical charge.

N-type material: A portion of a silicon crystal that has an excess of electrons and a deficiency of protons.

nucleus: The center of the atom, which consists of protons and neutrons.

O – P

Ohm: Unit of electrical resistance. One volt will cause a current of one flow through a resistance of one ohm.

Ohm's law: A law that states the relationship between voltage, current, and resistance in any circuit.

parallel circuit: A circuit that has two or more paths (branches) for current flow.

pathway: A conductor (commonly copper wire), which connects different parts of the circuit.

permanent (hard) magnet: A magnet that retains its magnetism after a magnetizing force has been removed.

phase: The uniform periodic change in amplitude or magnitude of an alternating current. Three phase alternating current consists of three different sine wave current flows, different in phase by 120 degrees from each other.

polarity: The state of an object as negative or positive.

polarity-sensitive circuit: A circuit that does not operate properly when exposed to the wrong polarity.

potential energy: Stored energy a body has due to its position, chemical state, or condition.

power: The rate at which work is done.

Power Transfer System: A system to safely wire your generator to your home's electrical system.

protons: The parts of the atom that have a positive electrical charge.

P-type material: A portion of a silicon crystal that has an excess of protons and a deficiency of electrons.

pulsating DC: DC voltage produced by rectifying (removing) one-half of an AC sine wave.

pulse: Half of a cycle.

R – S

rated speed: Revolutions per minute at which the set is designed to operate.

rated voltage: The rated voltage of an engine generator set is the voltage at which it is designed to operate.

rear bearing carrier: The casting which houses the rotor bearing which supports the rotor shaft.

rectifier: An electrical component that converts AC to DC by allowing the current to flow in only one direction.

regulator/rectifier: An electrical component that contains one or more diodes and a zener diode.

relay: An electrically operated switch usually used in control circuits and whose contacts are considered low amperage, compared to a contactor.

reserve capacity: The amount of time a battery can produce 25A at 80 F (26 degrees C).

resistance (R): The opposition to the flow of electrons.

resistive load: An applied load that reduces the possibility of the alternator system delivering full amperage through the circuit.

rotor: The rotating element of a generator.

secondary winding: A coil in which high voltage is induced for use at the spark plug.

self-inductance: A magnetic field created around a conductor whenever current moves through the conductor.

series circuit: A circuit having two or more components connected so that there is only one path for current flow.

series/parallel circuit: A circuit that contains a combination of components connected in series and parallel.

short circuit: An undesirable complete circuit path that bypasses the intended path and has very little resistance.

silicon controlled rectifier (SCR): A semiconductor that is normally an open circuit until voltage is applied, which switches it to the conducting state in one direction.

single phase: An AC load, or source of power normally having only two input terminals if a load or two output terminals if a source.

solenoid: A device that converts electrical energy into linear motion.

spark gap: The distance from the center electrode to the ground electrode on the spark plug.

spark plug: A component that isolates the electricity induced in the secondary windings and directs a high voltage charge to the spark gap at the tip of the spark plug.

spark tester: A test tool used to test the condition of the ignition system on a small engine.

starter motor: An electric motor that drives the engine flywheel when starting.

starter solenoid: An electrical switch, with internal contacts opened or closed, using a magnetic field produced by a coil.

stator: An electrical component that has a continuous copper wire (stator winding) wound on separate stubs exposing the wire to a magnetic field.

switch: Any component that is designed to start, stop, or redirect the flow of current in an electrical circuit.

T – Z

temporary (soft) magnet: A magnet that can only become magnetic in the presence of an external magnetic field.

trigger: A magnetic pick-up located near the crankshaft pulley that senses and counts crankshaft rotation.

troubleshooting: The systematic elimination of the various parts of a system or process to locate a malfunctioning part.

vibration mount: A rubber device located between the engine or generator and the cradle to minimize vibration.

volt (V): The unit of measure for electrical pressure difference between two points in a conductor or device.

voltage: The amount of electrical pressure in a circuit.

voltage regulator: A component which automatically maintains proper generator voltage by controlling the amount of DC excitation to the rotor.

voltage regulation system: A system that controls the amount of voltage required to charge the battery with a regulator/rectifier.

voltage source: A battery or some other voltage producing device.

watt: Unit of electrical power. In DC equals volts times amperes. In AC equals effective volts times effective amps times power factor times a consistent dependent on the number of phases. 1 kilowatt – 1,000 watts.











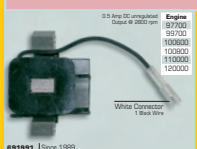





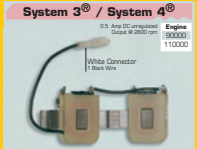
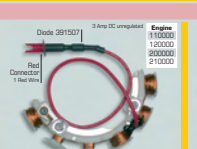
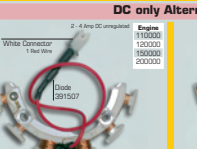

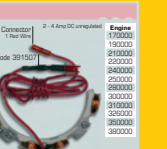

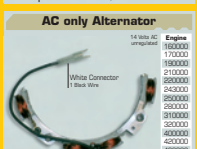
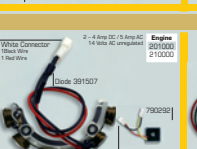
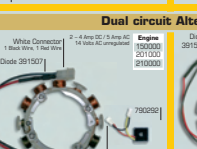
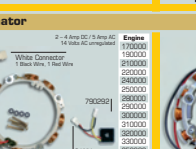



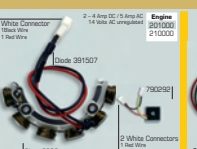

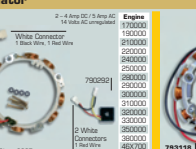
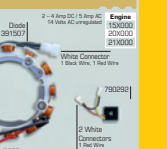

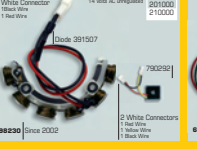

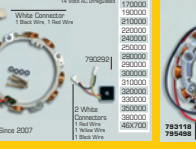







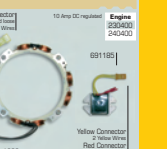

winding: All the coils of a generator. Stator winding consists of a number stator coils and their interconnections. Rotor windings consist of all windings and connections on the rotor poles.

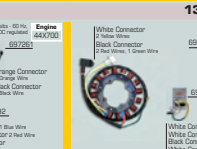
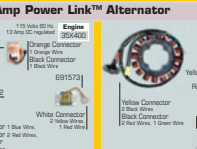
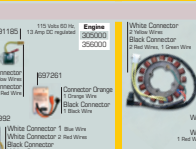
zener diode: A semiconductor that senses voltage to measure the state of battery charge at the battery terminals.

Briggs & Stratton Alternator Chart

You can order this chart from your source of supply or on ThePowerPortal.com under Customer Education.

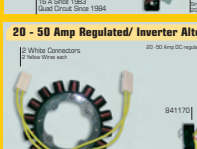
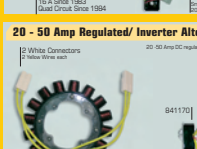
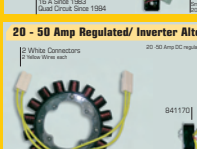
BRIGGS & STRATTON ALTERNATOR CHART

DC only Alternator					
 <p>691891 Since 1989 Alternator outside the flywheel</p>	 <p>791743 Since 2007</p>	 <p>793640 Since 2007</p>	 <p>494254 Since 1988</p>	 <p>394250 Since 1979</p>	 <p>691890 Since 1989</p>
System 3® / System 4®					
 <p>397880 Since 1981 Alternator outside the flywheel</p>	 <p>695730 Since 2000</p>	 <p>694457 Since 1999</p>	 <p>696578 Since 1973</p>	 <p>393809 Since 1978</p>	 <p>695730 Since 2000</p>
DC only Alternator					
 <p>391995 Since 1974 Small magnets</p>	 <p>698236 Since 2002</p>	 <p>699742 Since 2002</p>	 <p>699459 Since 2007</p>	 <p>795118 Since 2007</p>	 <p>795456 Since 2007</p>
AC only Alternator					
 <p>391995 Since 1974 Small magnets</p>	 <p>698236 Since 2002</p>	 <p>699742 Since 2002</p>	 <p>699459 Since 2007</p>	 <p>795118 Since 2007</p>	 <p>795456 Since 2007</p>
Dual circuit Alternator					
 <p>391995 Since 1974 Small magnets</p>	 <p>698236 Since 2002</p>	 <p>699742 Since 2002</p>	 <p>699459 Since 2007</p>	 <p>795118 Since 2007</p>	 <p>795456 Since 2007</p>
4 Amp Regulated Alternator					
 <p>715295 Since 1994 Small magnets</p>					
5 or 9 Amp Regulated Alternator					
 <p>698314 Since 2002</p>					
5 or 9 Amp Regulated or Tri-circuit Alternator					
 <p>691855 Since 1988 (5 & 9 Amp) 1976 Tri-circuit</p>					
10 Amp Alternator					
 <p>691181 Since 2003 Small magnets</p>	 <p>790320 Since 2004</p>	 <p>790325 Since 2004</p>	 <p>715184 Since 1994 Medium magnets</p>	 <p>691181 Since 2003 Small magnets</p>	 <p>715202 Since 1988</p>
13 Amp Power Link™ Alternator					
 <p>691574 Since 2002</p>	 <p>691574 Since 2002</p>	 <p>691574 Since 2002</p>	 <p>691574 Since 2002</p>	 <p>691574 Since 2002</p>	 <p>691574 Since 2002</p>
10, 13 and 16 A DC Regulated or Quad Circuit Alternator					
 <p>691181 Since 2003 Small magnets</p>					
14 Amp Regulated Alternator					
 <p>691181 Since 2003 Small magnets</p>					
20 Amp Regulated Alternator					
 <p>691181 Since 2003 Small magnets</p>					
20 - 50 Amp Regulated/ Inverter Alternator					
 <p>641170 Since 2004</p>					
40 Amp Alternator					
 <p>825084 Since 2000</p>					
60 Amp Alternator					
 <p>825077 Since 2002</p>					
Flywheel / Magnets					
					
<p>For Engines Series V™ WITH MAGNETS™</p> <ul style="list-style-type: none"> <li style="width: 50%;">• SMALL: 7/8" x 11/16" (22 x 17 mm) <li style="width: 50%;">• MEDIUM: 7/8" x 23/32" (22 x 23 mm) <li style="width: 50%;">• LARGE: 1-1/16" x 15/16" (27 x 24 mm) 					

Note: Unless specified, all tests must be carried out with the engine running at 3600 rpm. The values indicated are minimum values. If the value measured is lower than indicated a repeat test is advised before proceeding any further.

www.thepowerportal.com

BRIGGS&STRATTON CUSTOMER EDUCATION

For more educational information contact us at 1-800-934-7730

or e-mail us at cust.ed@basco.com

BRIGGSandSTRATTON.com • ThePowerPortal.com

CSSD / IDN EDUCATIONAL DIRECTORS

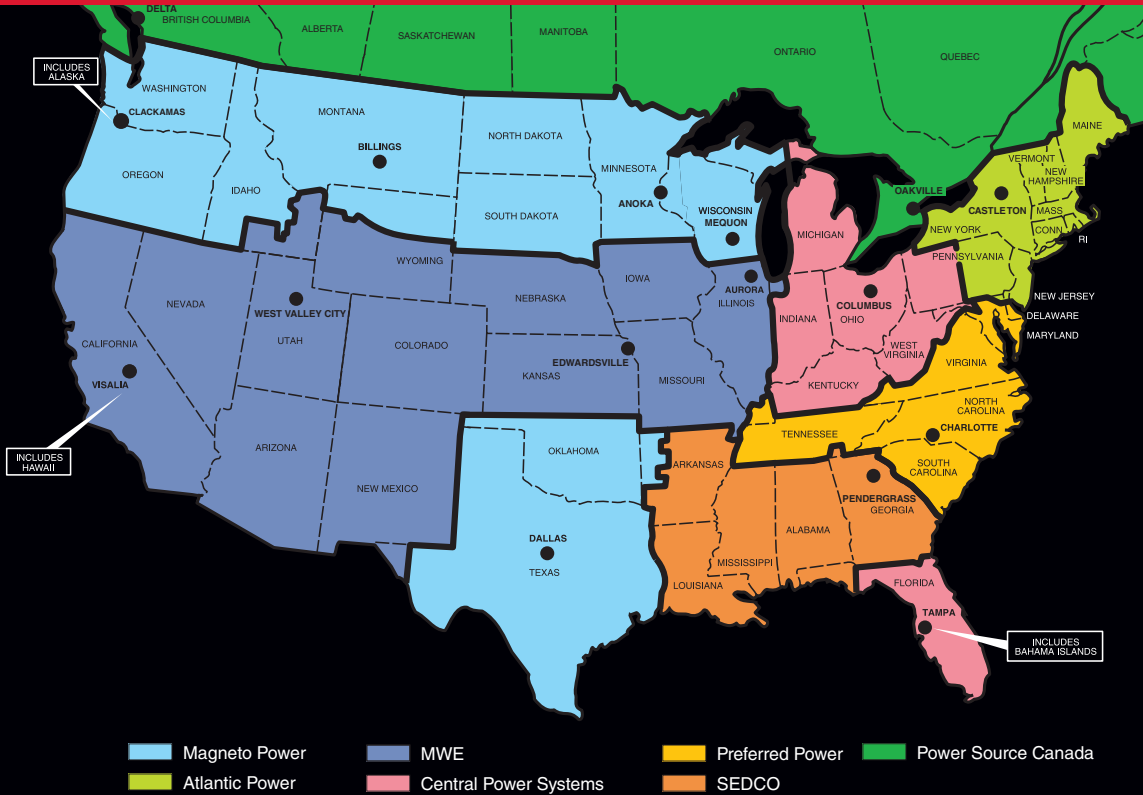

9/09

1. MAGNETO POWER, LLC	Anoka (Minneapolis)	MN	55303	Magneto Power, LLC	911 Lund Boulevard, Suite 300	Robert Moe	800-248-4016
	Dallas	TX	75235	Magneto Power, LLC of Texas	11011 Regency Crest Drive, Suite 100	Robert Ortolani	262-834-4394
	Mequon (Milwaukee)	WI	53092	Magneto Power, LLC	1000 W. Donges Bay Road, Suite 100	Robert Moe	262-834-4300
	Tualatin (Portland)	OR	97062	Magneto Power, LLC "West"	9991 S.W. Avery Street	Greg Muse	800-338-5168
2. MIDWEST ENGINE WAREHOUSE	Aurora (Chicago)	IL	60504	Midwest Engine Warehouse-IL	700 Enterprise Street	Tom Ziemann	630-862-3100
	Edwardsville (KC)	KS	66111	Midwest Engine Warehouse-KS	9630 Woodend Road	Tom Ziemann	913-543-7600
	Visalia	CA	93291	Midwest Engine Warehouse-CA	7101 W. Doe Avenue	John Reid	800-683-8484
	West Valley City (SLC)	UT	84120	Midwest Engine Warehouse-UT	3626 Parkway Boulevard	Tom Ziemann	801-886-2350
3. PREFERRED POWER, INC	Charlotte	NC	28216	Preferred Power, Inc.	6509-A Northpark Boulevard	Steve Krcelic	800-288-5310
4. POWER SOURCE CANADA, LTD	Delta (Vancouver)	BC	V3M 6R9	Power Source Canada, LTD	300-1628 Derwent Way	Mike Gulley	604-520-1294
	Oakville (Toronto)	ON	L6H 6X5	Power Source Canada, LTD	2815 Bristol Circle, Unit 1	Mike Gulley	905-829-0006
5. ATLANTIC POWER, INC	Castleton	NY	12033	Atlantic Power, Inc.	20 Empire State Boulevard	Art Falk	800-456-5692
6. CENTRAL POWER SYSTEMS	Columbus	OH	43228	Central Power Systems	3700 Paragon Drive	Pat Earnest	614-534-2152
	Tampa	FL	33610	Central Power Systems of Florida	4751 Oak Fair Boulevard	Ray Coyle	614-534-2140
7. SEDCO, INC	Pendergrass (Atlanta)	GA	30567	SEDCO, Inc.	225 Henry D. Robertson Boulevard	Wayne Crosby	800-346-4260

12/08



MS-0415-1/10

BRIGGS&STRATTON
CORPORATION

CUSTOMER EDUCATION
POST OFFICE BOX 702
MILWAUKEE, WI 53201 USA
800 934 7730 | cust.ed@basco.com
Copyright ©2010. All rights reserved.



THE POWER WITHIN™